

PHILIPS

Data handbook



Electronic
components
and materials

Components and materials

Book C11

1986

Varistors

Negative temperature coefficient thermistors

Positive temperature coefficient thermistors

Light dependent resistors

Humidity sensor

VARISTORS, THERMISTORS & SENSORS

	<i>page</i>
General information	ii
Negative temperature coefficient thermistors (NTC)	
Type selection	2
Introduction	6
How to measure NTC thermistor resistance	14
Choice of type	15
Applications	17
Device data	27
Positive temperature coefficient thermistors (PTC)	
Type selection	126
Introduction	129
Electrical properties	130
Explanation of terms	135
How to measure PTC thermistors	138
Applications	139
Device data	149
Varistors (VDR)	
Type selection	306
Introduction	308
Electrical properties	309
How to measure varistors	317
Applications	319
Device data	323
Sensors	
General light dependent resistors (LDR)	370
Survey	371
Device data	372
Humidity sensor	381
Index of catalogue numbers	383

For easy reference, catalogue numbers (12 digits) are at the top of each page. Orders should always state the 12-figure catalogue number.

An index of catalogue numbers is at the back of this book and lists the relevant page numbers.

All dimensions on drawings are in mm unless otherwise indicated. According to the S.I. units the symbol K (Kelvin) is used instead of °C in combinations such as K/W. Also ΔT is in K. Atmospheric pressure is given in kPa instead of millibars, mm Hg, etc. 1000 mbar = 100 kPa.

Some devices are labelled "**Maintenance Type**". The relevant resistors are available for equipment maintenance only and are no longer recommended for equipment production.

Of those types labelled "**DEVELOPMENT DATA**" the specifications are subject to change without notice.

DATA HANDBOOK SYSTEM

Our Data Handbook System comprises more than 60 books with specifications on electronic components, subassemblies and materials. It is made up of four series of handbooks:

ELECTRON TUBES	BLUE
SEMICONDUCTORS	RED
INTEGRATED CIRCUITS	PURPLE
COMPONENTS AND MATERIALS	GREEN

The contents of each series are listed on pages iv to viii.

The data handbooks contain all pertinent data available at the time of publication, and each is revised and reissued periodically.

When ratings or specifications differ from those published in the preceding edition they are indicated with arrows in the page margin. Where application information is given it is advisory and does not form part of the product specification.

Condensed data on the preferred products of Philips Electronic Components and Materials Division is given in our Preferred Type Range catalogue (issued annually).

Information on current Data Handbooks and on how to obtain a subscription for future issues is available from any of the Organizations listed on the back cover.

Product specialists are at your service and enquiries will be answered promptly.

ELECTRON TUBES (BLUE SERIES)

The blue series of data handbooks comprises:

- T1** Tubes for r.f. heating
- T2a** Transmitting tubes for communications, glass types
- T2b** Transmitting tubes for communications, ceramic types
- T3** Klystrons
- T4** Magnetrons for microwave heating
- T5** Cathode-ray tubes
Instrument tubes, monitor and display tubes, C.R. tubes for special applications
- T6** Geiger-Müller tubes
- T7** Gas-filled tubes (will not be reprinted)
- T8** Colour display systems
Colour TV picture tubes, colour data graphic display tube assemblies, deflection units
- T9** Photo and electron multipliers
- T10** Plumbicon camera tubes and accessories
- T11** Microwave semiconductors and components
- T12** Vidicon and Newvicon camera tubes
- T13** Image intensifiers
- T14** Infrared detectors
- T15** Dry reed switches
- T16** Monochrome tubes and deflection units
Black and white TV picture tubes, monochrome data graphic display tubes, deflection units

} Data collations on these subjects are available now.
Data Handbooks will be published in 1985.

SEMICONDUCTORS (RED SERIES)

The red series of data handbooks comprises:

- S1 Diodes**
Small-signal germanium diodes, small-signal silicon diodes, voltage regulator diodes (< 1,5 W), voltage reference diodes, tuner diodes, rectifier diodes
- S2a Power diodes**
- S2b Thyristors and triacs**
- S3 Small-signal transistors**
- S4a Low-frequency power transistors and hybrid modules**
- S4b High-voltage and switching power transistors**
- S5 Field-effect transistors**
- S6 R.F. power transistors and modules**
- S7 Surface mounted semiconductors**
- S8 Devices for optoelectronics**
Photosensitive diodes and transistors, light-emitting diodes, displays, photocouplers, infrared sensitive devices, photoconductive devices.
- S9 Power MOS transistors**
- S10 Wideband transistors and wideband hybrid IC modules**
- S11 Microwave transistors**
- S12 Surface acoustic wave devices**

INTEGRATED CIRCUITS (PURPLE SERIES)

The purple series of data handbooks comprises:

EXISTING SERIES

Superseded by:

IC1	Bipolar ICs for radio and audio equipment	IC01N
IC2	Bipolar ICs for video equipment	IC02Na and IC02Nb
IC3	ICs for digital systems in radio, audio and video equipment	IC01N, IC02Na and IC02Nb
IC4	Digital integrated circuits CMOS HE4000B family	
IC5	Digital integrated circuits – ECL ECL10 000 (GX family), ECL100 000 (HX family), dedicated designs	IC08N
IC6	Professional analogue integrated circuits	
IC7	Signetics bipolar memories	
IC8	Signetics analogue circuits	IC11N
IC9	Signetics TTL logic	IC09N and IC15N
IC10	Signetics Integrated Fuse Logic (IFL)	IC13N
IC11	Microprocessors, microcomputers and peripheral circuitry	

NEW SERIES

IC01N	Radio, audio and associated systems Bipolar, MOS	(published 1985)
IC02Na	Video and associated systems Bipolar, MOS Types MAB8031AH to TDA1524A	(published 1985)
IC02Nb	Video and associated systems Bipolar, MOS Types TDA2501 to TEA1002	(published 1985)
IC03N	Integrated circuits for telephony	(published 1985)
IC04N	HE4000B logic family CMOS	
IC05N	HE4000B logic family – uncased ICs CMOS	(published 1984)
IC06N	High-speed CMOS; PC54/74HC/HCT/HCU Logic family	(published 1985)
IC07N	High-speed CMOS; PC54/74HC/HCT/HCU – uncased ICs Logic family	
IC08N	ECL 10K and 100K logic families	(published 1984)
IC09N	TTL logic series	(published 1984)
IC10N	Memories MOS, TTL, ECL	
IC11N	Linear LSI	(published 1985)
IC12N	Semi-custom gate arrays & cell libraries ISL, ECL, CMOS	
IC13N	Semi-custom Integrated Fuse Logic	(published 1985)
IC14N	Microprocessors, microcontrollers & peripherals Bipolar, MOS	
IC15N	FAST TTL logic series	(published 1984)

Note

Books available in the new series are shown with their date of publication.

COMPONENTS AND MATERIALS (GREEN SERIES)

The green series of data handbooks comprises:



- C1 Programmable controller modules**
PLC modules, PC20 modules
- C2 Television tuners, coaxial aerial input assemblies, surface acoustic wave filters**
- C3 Loudspeakers**
- C4 Ferroxcube potcores, square cores and cross cores**
- C5 Ferroxcube for power, audio/video and accelerators**
- C6 Synchronous motors and gearboxes**
- C7 Variable capacitors**
- C8 Variable mains transformers**
- C9 Piezoelectric quartz devices**
- C10 Connectors**
- C11 Non-linear resistors**
Voltage dependent resistors (VDR), light dependent resistors (LDR), negative temperature coefficient thermistors (NTC), positive temperature coefficient thermistors (PTC)
- C12 Potentiometers, encoders and switches**
- C13 Fixed resistors**
- C14 Electrolytic and solid capacitors**
- C15 Ceramic capacitors**
- C16 Permanent magnet materials**
- C17 Stepping motors and associated electronics**
- C18 Direct current motors**
- C19 Piezoelectric ceramics**
- C20 Wire-wound components for TVs and monitors**
- C21* Assemblies for industrial use**
HNIL FZ/30 series, NORbits 60-, 61-, 90-series, input devices
- C22 Film capacitors**

* Will be issued in 1985.

NEGATIVE TEMPERATURE COEFFICIENT THERMISTORS (NTC)

TYPE SELECTION

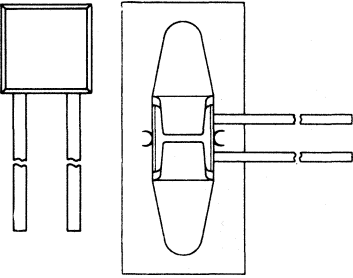
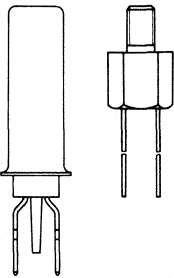
type	P_{max} W	temp. range at zero power °C	B _{25/85} -value K	R ₂₅ Ω	catalogue number	page
DISC	1	-25 to +125	2800 to 5450 ± 5%	4 to 1300	2322 610 1	27
		25 to +100 -25 to +155	2975	930 5	2322 611 90027 2322 644 90012	32 117
	0,25	-25 to +125	3660 to 4150 ± 5%	2,7 k to 330 k	2322 640 1	65
	0,25	-55 to +85	4000	R-30 = 50 000 R-10 = 15 000 R-10 = 15 000 R+25 = 2 700	2322 640 90012 2322 640 90014	88 94
	0,5	-25 to +125	2675 to 4650 ± 5%	3,3 to 470 k	2322 642 6	101
		-25 to +155	4650 3350	82 min. 15	2322 644 90004 2322 644 90005	111 111
	0,1	-40 to +110	3965 ± 1,25%	5 k to 10 k		
	0,25 0,75	-40 to +110	3965 ± 1,25%	1 k to 5 k	2322 645	119

 <p>moulded</p>	0,25	-55 to + 85	4000		R ₋₃₀ = 50 000 R ₋₁₀ = 15 000	2322 640 90013 2322 640 98013	90 90
	0,25	-55 to + 85	4000		R ₋₁₀ = 15 000 R ₊₂₅ = 2 700	2322 640 90015 2322 640 98015	97 97
	0,25	-10 to + 125	3750		R ₊₂₅ = 12 000 R ₊₁₀₀ = 950	2322 640 90004 2322 640 98004	71 71
	0,25	-25 to + 200	4300		R ₊₁₀₀ = 16 700 R ₊₂₀₀ = 1 120	2322 640 90005 2322 640 98005	77 77
 <p>in special housing</p>	0,25	-25 to + 110	3700 3720		R ₊₂₅ = 12 k R ₊₉₀ = 1300	2322 640 90007 2322 640 90021	83 83
	0,5	-25 to + 100	2675 to 4650 ± 5%		3,3 to 470 k	2322 642 7	108
 <p>ROD</p>	0,1	+ 25 to + 300			220 k	2322 633 7 . 224	57

NTC THERMISTORS

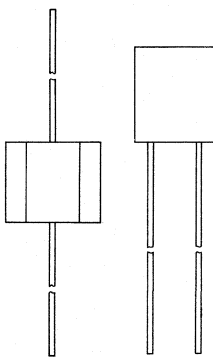
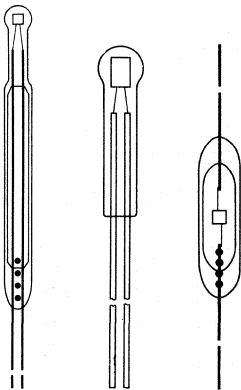
type	P_{max} W	temp. range at zero power $^{\circ}C$	$B_{25/85}$ value $\pm 5\%$ K	R_{25} Ω	catalogue number	page
MINIATURE BEAD 		-55 to +200	2075 to 4100	1k to 1M	2322 633 0	47
		-55 to +200	2075 to 4100	1k to 1M	2322 633 1	47
glass encapsulated 	0,1	-25 to +200/300	2075 to 4100	1k to 1M	2322 626 1	33
	0,1	-55 to +200/300	2075 to 4100	1k to 1M	2322 626 2	39
	0,06	-55 to +200	2075 to 4100	1k to 1M	2322 633 2	51

INDIRECTLY HEATED

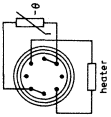
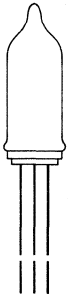

0,015

-25 to + 85

3860

15k

2322 628 90016

44

INTRODUCTION

NTC thermistors are resistors with a high negative temperature coefficient of resistance. They are manufactured from oxides of the iron group of transition elements e.g. Cr, Mn, Fe, Co or Ni. These oxides have a high resistivity in the pure state, but can be transformed into semiconductors by adding small amounts of foreign ions which have a different valency.

Examples are:

- iron oxide Fe_2O_3 , where a small part of the Fe^{3+} -ions are replaced by Ti^{4+} -ions. These Ti^{4+} -ions are compensated by an equal amount of Fe^{2+} -ions in order to maintain electroneutrality. At low temperatures the extra electrons of the Fe^{2+} -ions are situated on Fe-ions next to the Ti^{4+} -ions, but at higher temperatures they are gradually loosened from these sites and contribute to the conductivity. In this case we have obtained an electron- or n-type semiconductor.
- Nickel oxide NiO, or cobalt oxide CoO, with a partial substitution of Li^{1+} -ions for the Ni^{2+} - or Co^{2+} -ions. In this case the Li^{1+} -ions are compensated by an equal amount of Ni^{3+} - or Co^{3+} -ions. At low temperatures the so-called electron-holes (missing electrons) of the trivalent ions are near the foreign ions and again free to move through the crystals at higher temperatures. In this case a positively charged particle is the mobile charge carrier and therefore these materials are called p-type semiconductors.

Stabilizing oxides are sometimes added to achieve improved reproducibility and stability of the characteristics. Which of these compositions is used depends entirely on the required temperature coefficient and the specific resistance.

In examples a. and b. the conductivity σ of the materials can be generally described by

$$\sigma = n e \mu$$

where e represents the unit of electric charge and n and μ the concentration and the mobility of the charge carriers respectively.

Both n and μ depend on temperature. For n this dependence is exponential according to a Boltzmann law.

$$n \propto e^{-q_1/kT}$$

where q_1 is related to the electrostatic binding energy of the carriers to the foreign ions. It is uncertain whether the temperature dependence of the mobility is comparable to that of charge carriers in germanium-type semiconductors ($\mu \propto T^b$) or to that of ionic conductors where the ions need a thermal activation energy q_2 for each jump to a neighbour site (hopping process). In the latter case the temperature dependence is described by:

$$\mu \propto \frac{e^{-q_2/kT}}{T} \quad (\propto = \text{direct proportional to})$$

The total temperature dependence of the conductivity is generally proportional to:

$$\sigma \propto T^c \cdot e^{-(q_1 + q_2)/kT}$$

where q_2 may be zero. In practice the exponential factor is the most important one, so that the resistance variation of these thermistors over a wide temperature range can be represented by:

$$R = A e^{B/T}$$

where R = resistance at absolute temperature T ,

A and B are constants for a given resistor and

e = the base of the natural logarithm ($e = 2,718$).

Resistance is plotted as a function of temperature in Fig. 1, for three types with different values of A and B .

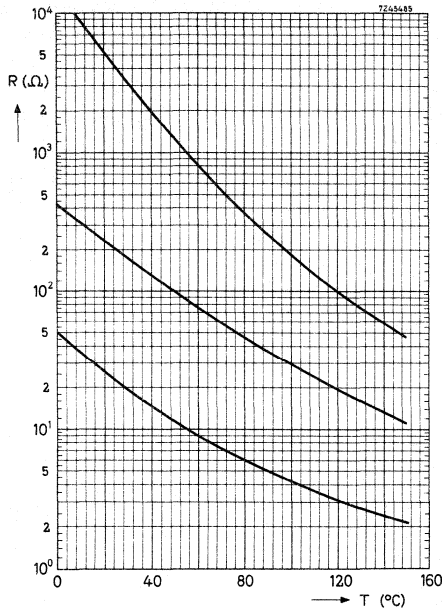

Fig. 1.

MANUFACTURE

The manufacturing process is comparable to that of ceramics. After intensive mixing and addition of a plastic binder, the mass is shaped into the required forms, e.g. by extrusion (rods) or pressing (discs) and fired at a temperature high enough to sinter the constituent oxide. Electrical contacts are then added by burning in with silver paste or by other methods such as electroplating or metal spraying.

Miniature NTC thermistors are made by placing a bead of oxide paste between two parallel platinum alloy wires and then drying and sintering. The platinum alloy wires are 60 μm diameter and 0,25 mm apart. During sintering the bead shrinks onto the wires to make a solid and reliable contact. Miniature NTC thermistors are usually mounted in glass to protect them against aggressive gases and fluids.

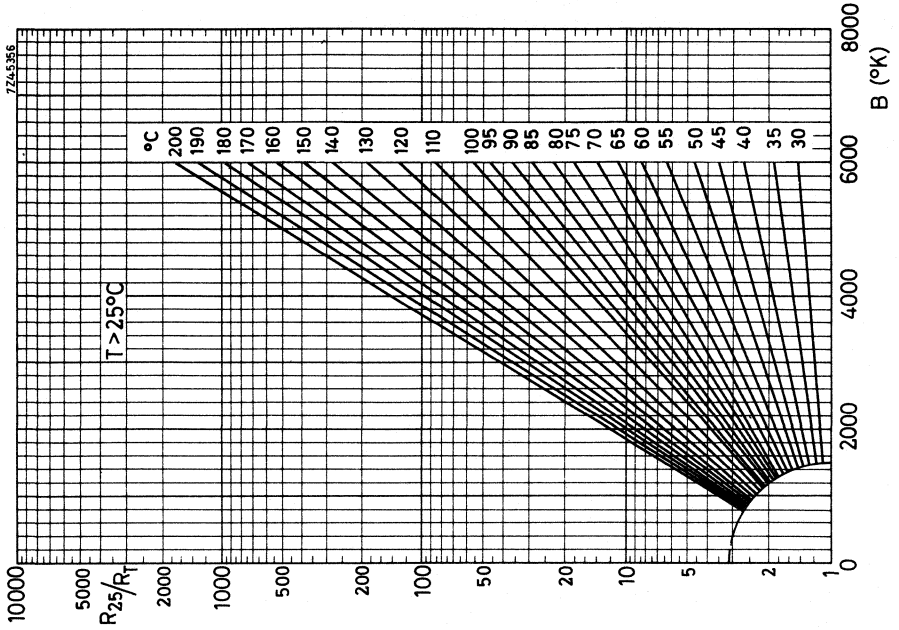

Fig. 3 R_{25}/R_T as a function of B-value with temperature as a parameter.

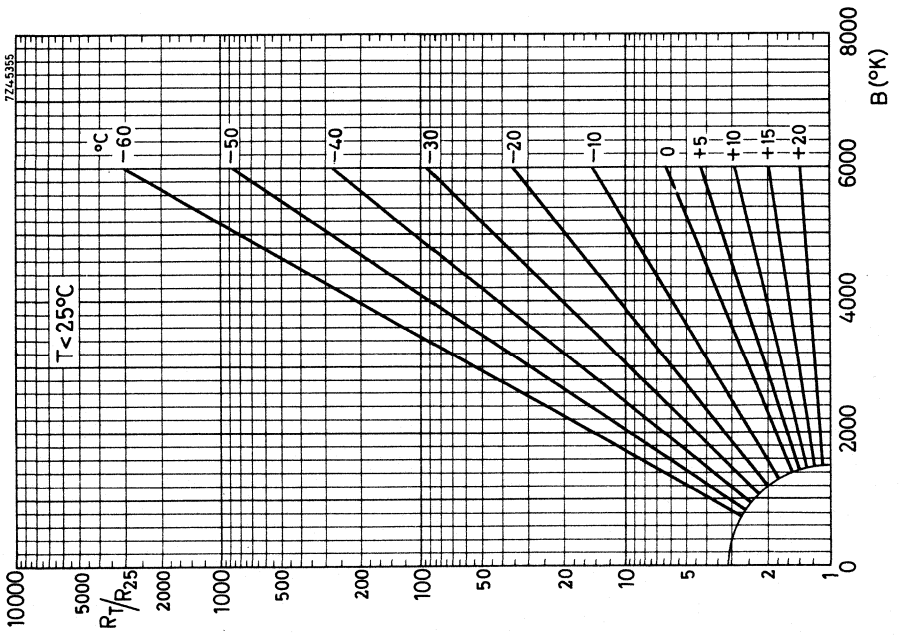

Fig. 2 R_T/R_{25} as a function of B-value with temperature as a parameter.

For a particular NTC thermistor the value of B may be found as follows. The resistance value is measured at two temperatures, T_1 and T_2 :

$$R_1 = Ae^{B/T_1} \text{ and } R_2 = Ae^{B/T_2}.$$

Dividing yields:

$$\frac{R_1}{R_2} = e^{(B/T_1 - B/T_2)},$$

or:

$$\log R_1 - \log R_2 = B (1/T_1 - 1/T_2) \log e,$$

solving for B gives:

$$B = \frac{\ln R_1/R_2}{1/T_1 - 1/T_2} \quad (2)$$

In practice B varies slightly with increasing temperature.

From Eq. (1) the temperature coefficient of an NTC may be derived:

$$\alpha = \frac{1}{R} \cdot \frac{dR}{dT} = -\frac{B}{T^2}. \quad (3)$$

For the different materials the constant B may vary between 2000 and 5500 K:

e.g. a value of 3600 yields $\alpha = -4\%$ per K at a temperature of 300 K. For calculating the resistance of an NTC at a particular temperature, when R_{25} and B are given in the data, the graphs of Figs 2 and 3 may be used, where for different B-values R_{25}/R_T and R_T/R_{25} are plotted against the B-value with the temperature of the NTC thermistor as parameter.

V/I CHARACTERISTICS

Fig. 4 shows the relationship between current and voltage drop over the NTC thermistor when the latter is heated by this current to a temperature much higher than the ambient temperature. This characteristic was measured at a constant ambient temperature after equilibrium had been reached. For very small currents, the power consumption is too small to register a distinct rise in temperature or a decrease in resistance. In that part of the characteristic the relationship between voltage and current is therefore linear.

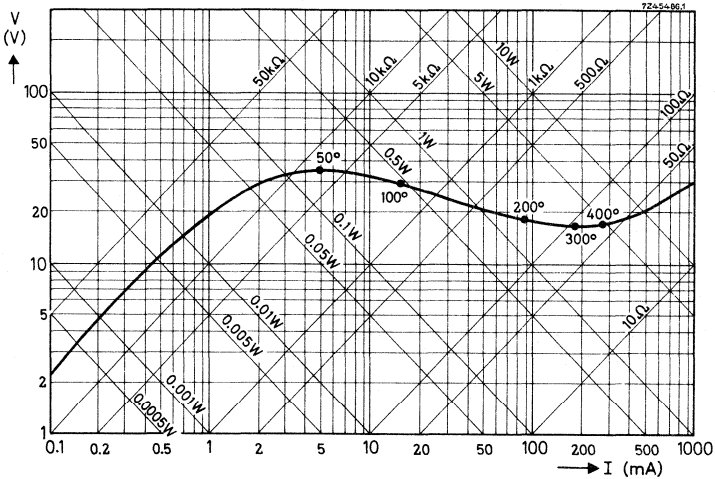

Fig. 4 Voltage versus current characteristics of an NTC thermistor.

Assuming:

- a constant temperature throughout the body of the thermistor;
- the heat transfer to be proportional to the difference in temperature between thermistor and surrounding medium (which is true for low temperatures);
- the resistance to be defined by eq. (1)

$$R = \frac{V}{I} = Ae^{B/T},$$

or:

$$\log_e R = \log_e A + B/T. \quad (4)$$

In case of equilibrium

$$W = VI = \delta (T - T_0), \quad (5)$$

in which T_0 is the ambient temperature and δ the dissipation factor (definition on next page).

From eqs (5) and (4) follows:

$$\log_e V + \log_e I = \log_e \delta + \log_e (T - T_0), \quad (6)$$

$$\log_e V - \log_e I = \log_e A + B/T. \quad (7)$$

Combination of these two yields:

$$\log_e V = \frac{1}{2} \log_e A \delta + \frac{1}{2} \log_e (T - T_0) + B/2T. \quad (8)$$

This form has an extreme as a function of T if:

$$\frac{d \log_e V}{dT} = 0. \quad (9)$$

In that case

$$\frac{1}{2(T - T_0)} - \frac{B}{2T^2} = 0 \quad (10)$$

which is true only for those values of T which satisfy:

$$T^2 - BT + BT_0 = 0, \quad (11)$$

$$T_{\max} = \frac{1}{2}B \pm \sqrt{\frac{1}{4}B^2 - BT_0}. \quad (12)$$

(The value with the minus sign gives the temperature corresponding to the maximum value of the voltage.) Only if $B > 4T_0$ will this maximum be present. For the practical values of B (2000 – 4000 K) the temperature T_{\max} lies between 85 °C and 45 °C.

From these considerations, which are valid for static conditions only, it follows that the temperature corresponding to the maximum voltage only depends on the B-value of the material and not the actual resistance value.

THERMAL TIME CONSTANT

The thermal time constant (τ) is defined as the ratio of the heat capacity (H) of the thermistor to its dissipation factor (δ).

The heat capacity (H) is the electrical energy the thermistor needs to raise 1 K in temperature (unit J/K).

The dissipation factor (δ) is the ratio at a specified ambient temperature of a change in power dissipation in a thermistor to the resultant body temperature change (unit mW/K).

The thermal time constant is the time required for the temperature of a thermistor to change by 63,2% of the difference between its initial and final body temperatures (according to IEC 539; 85 °C and 25 °C respectively), when subjected to a step function temperature change.

H is entirely dependent on the component design. The thermal time constant depends on δ which varies for different media.

The thermal time constants mentioned in the data sheets are measured as follows, the method used depending on the application:

- by cooling in air under zero power conditions (τ_c).
- by warming or cooling, transferring the thermistor from ambient temperature of + 25 °C to a bath with a fluid of a higher or lower temperature under zero power conditions (τ_r , termed "response time" in the data sheets).
- by internal heating, subjecting the thermistor to a constant voltage or current (τ_v or τ_i).

NTC THERMISTORS

If the thermistor has a uniform temperature during cooling, the following equation is valid for the cooling of an NTC in the time interval dt :

$$-HdT = \delta (T - T_0) dt \quad (13)$$

in which T_0 is the ambient temperature.

Eq. (13) yields: $(T - T_0) = (T_1 - T_0) e^{-t/\tau_c}$ (14)

In a corresponding way the following equation can be derived for warming up:

$$(T - T_0) = (T_1 - T_0) (1 - e^{-t/\tau_r}).$$

The third case is more complicated and is based on the equation:

$$P dt = H dT + \delta (T_1 - T_0) dt.$$

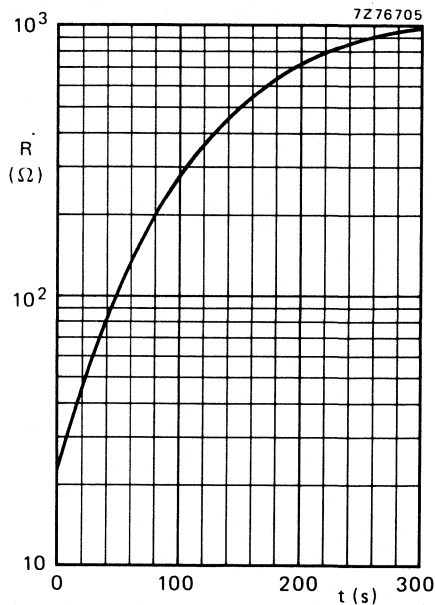

Fig. 5 Variation of resistance with time under normal cooling conditions of a rod type NTC. Ambient temperature 25 °C.

SPREAD

Resistance specified at +25 °C (R_{25})

The R_{25} and the B-value are specified with a certain spread. The tolerance on the resistance at 25 °C is normally specified as $\pm 5\%$ or $\pm 10\%$.

The B-value usually has a tolerance of $\pm 5\%$. Due to the spread in B-value, the deviation from the nominal curve at temperatures other than 25 °C can be greater than the specified tolerance at 25 °C (Fig. 6).

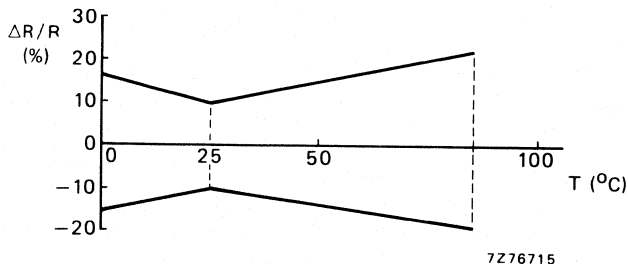

Fig. 6.

Temperature tolerances

For temperature sensors, it is appropriate to express the measuring error as a temperature tolerance rather than as $\Delta R/R$.

For one-point sensors, the temperature tolerances corresponding with the spread in R_{ref} and B-value (T_{ref} = reference temperature; usually 25 °C) can be calculated from:

$$R_T = R_{ref} \cdot e^{B \left(\frac{1}{T} - \frac{1}{T_{ref}} \right)},$$

in which T and T_{ref} are in K.

The result of the calculation yields

at $T \approx T_{ref}$:

$$\pm \Delta T_{ref} = \frac{\Delta R_{ref}}{R_{ref}} \cdot \frac{1}{B/T^2}$$

at $T < T_{ref}$:

$$\pm \Delta T = \frac{\frac{\Delta R_{ref}}{R_{ref}} + \frac{\Delta B}{B} B \left(\frac{1}{T} - \frac{1}{T_{ref}} \right)}{B/T^2}$$

at $T > T_{ref}$:

$$\pm \Delta T = \frac{\frac{\Delta R_{ref}}{R_{ref}} + \frac{\Delta B}{B} B \left(\frac{1}{T_{ref}} - \frac{1}{T} \right)}{B/T^2}$$

For a practical case, the maximum error in K as a function of the temperature to be measured is expressed in Fig. 7.

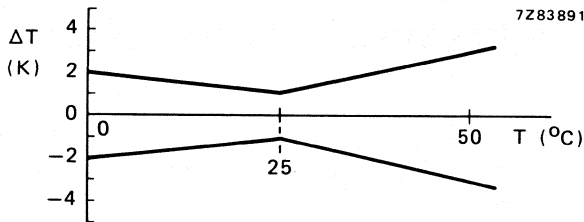

Fig. 7.

Resistance specified at more than one temperature (2 or 3-point sensors)

Thermistors which are specified at 2 or 3 points of their R/T characteristic are more accurate. They have a closer tolerance and the spread in B-value has less influence because it is included in the tolerance at the specified points.

The tolerances in the reference points can be expressed either as a temperature deviation for the reference resistance or as a resistance tolerance at the reference temperature. This has no influence on the resulting measuring error which is minimum in the temperature region between the reference points, as illustrated in Fig. 8.

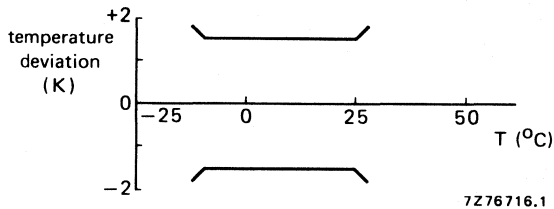

Fig. 8.

From Figs 7 and 8 it is obvious that 2 or 3-point sensors are particularly suited for applications with the following characteristics:

- temperature measurement over a certain temperature range
- high accuracy
- no further calibration for sensor tolerances in the electrical circuitry.

HOW TO MEASURE NTC THERMISTORS

The published R_T values are measured at the temperature T.

The published B-value at 25 °C is the result of a measurement at 25 °C and one at 85 °C. So, please, use these two temperatures for checking.

The following general precautions have to be taken when measuring NTC thermistors:

- Never measure thermistors in air as this is quite inaccurate and gives deviations of 1 or 2 K. For measurement at room temperature or below, use petrol or some other non-conductive and non-aggressive fluid. For higher temperatures use oil, preferably silicon oil.
- Use a thermostat with an accuracy of at least 0,1 °C. Even if the liquid is well stirred, there is still a temperature gradient in the fluid. So measure the temperature as close to the NTC as possible.
- After placing the NTC in the thermostat wait until temperature equilibrium between the NTC and the fluid is obtained. For some types this may take more than 1 minute.
- Keep the measuring voltage as low as possible otherwise the NTC will be heated by the measuring current. Miniature NTC thermistors are especially sensitive in this respect. Measuring voltages of less than 0,5 V are recommended.
- For high temperature measurements it is recommended that stem correction be applied to the thermometer reading.

CHOICE OF TYPE

When selecting an NTC thermistor the following main characteristics should be considered:

- Resistance value(s) and temperature coefficient.
- Accuracy of resistance value(s).
- Power to be dissipated
 - (a) without perceptible change in resistance value due to self heating
 - (b) with maximum change in resistance value.
- Permissible temperature range.
- Thermal time constant, if applicable.
- Form best suited to the purpose:
 - basic forms are rod, disc and bead.
- Protection against undesired external influences, if necessary.

When it is impossible to find an NTC thermistor to fulfil all requirements, it is often more economical to adapt the values of other circuit components to the value of a series-manufactured NTC. Sometimes, a standard NTC can be used with simple parallel and series resistors where otherwise a special type would have been necessary.

If no suitable combination can be found, the development of a special type can be considered. In this case a specification of the requirements is necessary. A description of the circuit in which the NTC has to be used is most useful.

DEVIATING CHARACTERISTICS

The following example explains the resistance values resulting from combinations of NTCs with normal resistors.

Suppose an NTC must have a resistance of 50Ω at 30°C and 10Ω at 100°C . A standard type having this characteristic is not included in our programme. The problem may, however, be solved by using a standard NTC and two fixed resistors. If an NTC disc with a cold resistance of 130Ω is mounted in a series and parallel arrangement with two fixed resistors of 6Ω and 95Ω as illustrated in Fig. 9, the resistance of the combination at 30°C and at 100°C will meet the requirements. Figure 10 shows the new resistance versus temperature graph, together with that of the NTC thermistor. It should be remembered that the temperature coefficient of the combination will always be lower than that of the NTC thermistor alone. This is clearly illustrated by Fig. 11, where the change in the resistance/temperature graph is shown for different values of series and parallel resistors.

REMARKS ON THE USE OF NTC THERMISTORS

Do not use unprotected thermistors in conducting fluids or aggressive and reducing gases which may cause a change in thermistor characteristics.

For temperature measurements do not use too high a voltage on the NTC thermistor as self-heating may cause incorrect readings. The dissipation constant indicates the maximum permissible measuring power.

NTC THERMISTORS

Choice of type

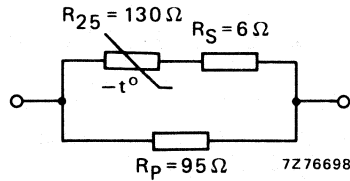

Fig. 9 NTC thermistor/resistor combination to change the R/T characteristic.

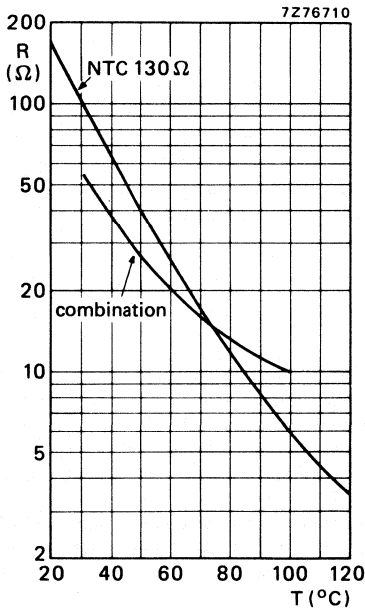

Fig. 10 Resistance as a function of temperature for the circuit of Fig. 7.

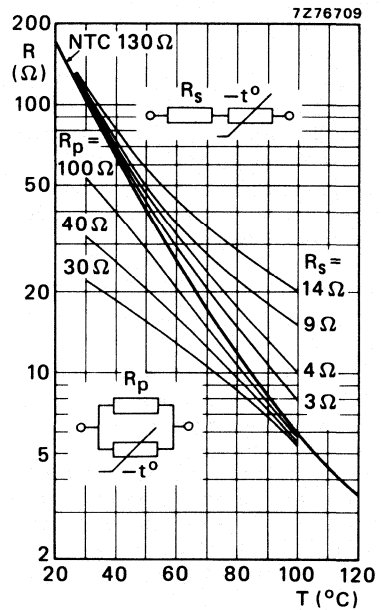

Fig. 11 Resistance as a function of temperature with the values of series and parallel resistors as parameters.

APPLICATIONS

According to the essential properties of the NTC their applications may be classified into three main groups:

- (I) Applications in which advantage is taken of the dependence of the resistance on the temperature:

$$R = f(T).$$

This group is split into two subsections:

- (a) The temperature of the NTC thermistor is determined only by the temperature of the ambient medium (or by the current in a separate heater winding).
 - (b) The temperature of the NTC thermistor is also determined by the dissipation in the NTC thermistor itself.
- (II) Applications in which the time dependence is decisive.
In that case the temperature is considered as a parameter, and is written:

$$R = f(t).$$

This group comprises all applications which make use of the thermal inertia of NTC thermistors.

- (III) The third group of applications uses mainly the property of the temperature coefficient being highly negative:

$$\alpha < 0.$$

Also in this group applications are listed which take advantage of the fact that the absolute value of the temperature coefficient is so high, that a part of the $V = f(I)$ curve shows a negative slope.

NTC THERMISTORS

APPLICATION EXAMPLES

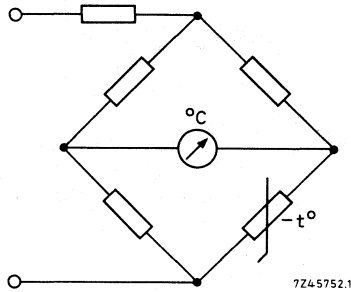

Fig. 12 Temperature measurement in industrial and medical thermometers.

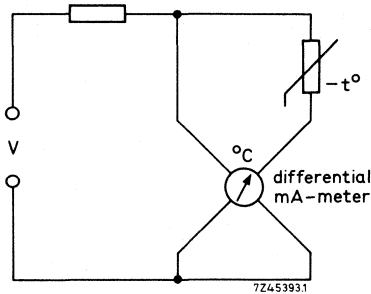
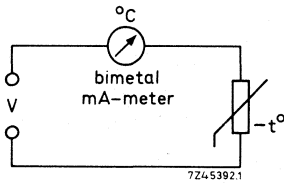

Fig. 13
Temperature measurement in cars.
Cooling water measurements with bimetal
or differential millimeters.

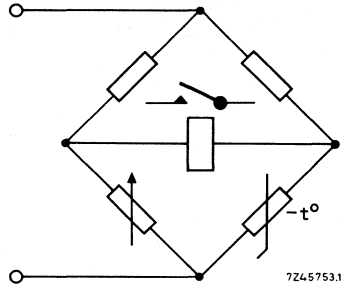

Fig. 14
Temperature control with a bridge
incorporating an NTC thermistor and a
relay or a static switching device.

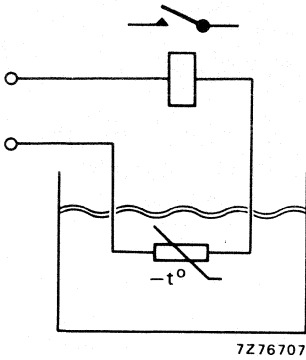

Fig. 15 Liquid level control.

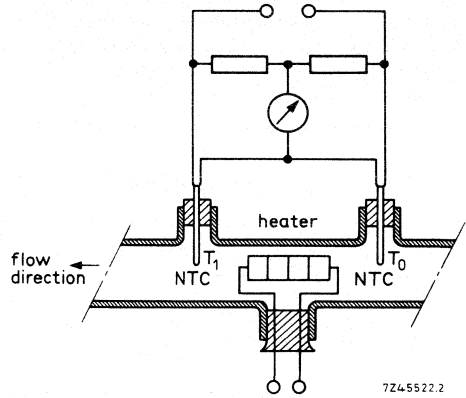

Fig. 16
Flow measurement of liquids. The temperature difference between T_1 and T_0 is a measure for the velocity of the fluid.

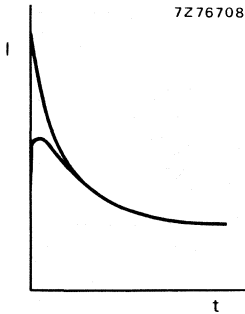
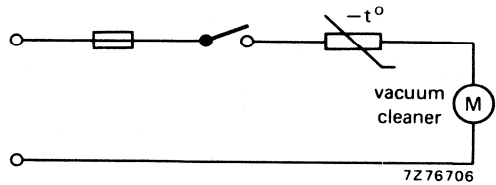
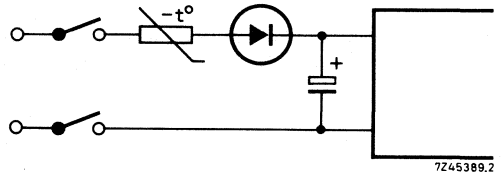

Fig. 17
Inrush current limiter, e.g. for protection of Si-diodes, fuses and switches.



NTC THERMISTORS

Fig. 18
 Delaying action of relays. Due to the thermal inertia of the NTC, it takes some time before the relay is activated. If necessary the NTC can be short-circuited after the relay is activated thus leaving the NTC time for cooling.

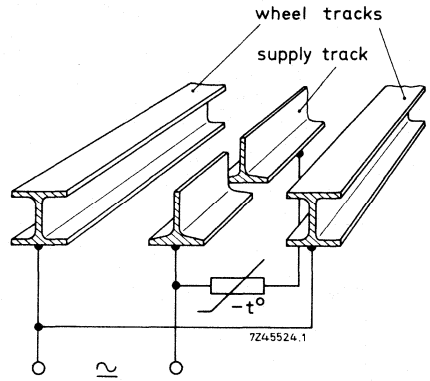
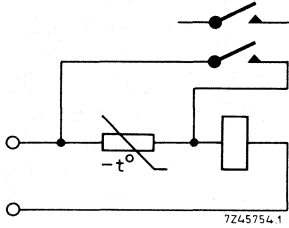

Fig. 19
 Model trains. As soon as the train comes on the isolated supply trip, it stops. The NTC heats up and gradually the train starts again.

Fig. 20
 Gain compensation or gain control with an indirectly heated NTC.

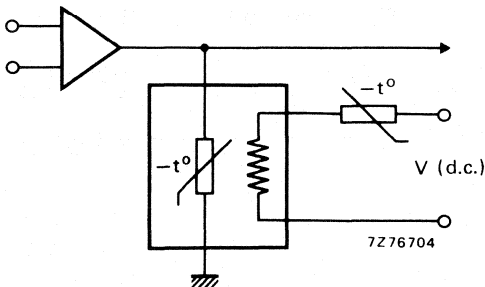
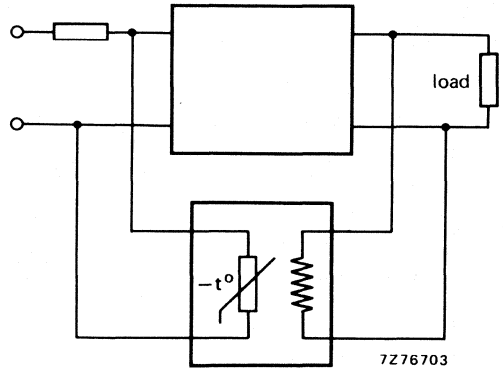

Fig. 21
 Compensation for the influence of ambient temperature variations in an h.f. amplifier.

Fig. 22
Temperature compensation in transistor circuits. Push-pull compensation.

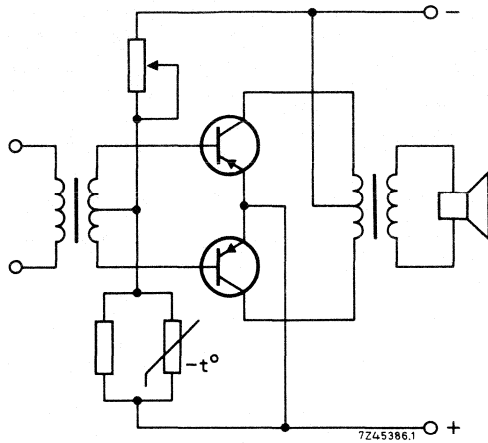

Fig. 23
Transformerless audio output stage with temperature compensation.

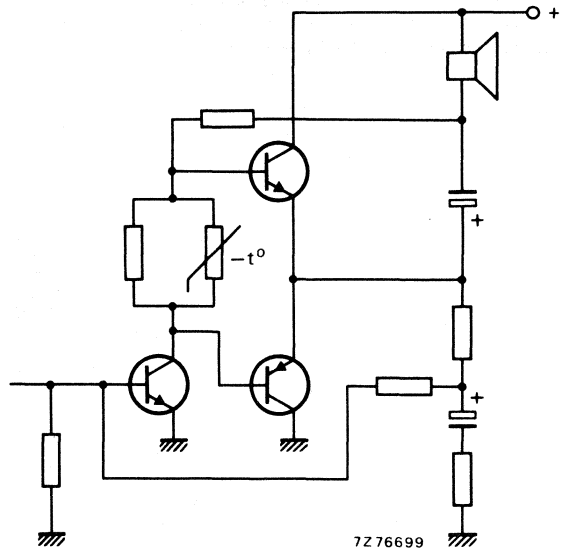

Fig. 24
Stabilization with temperature of an
a.g.c. amplifier in a television set.

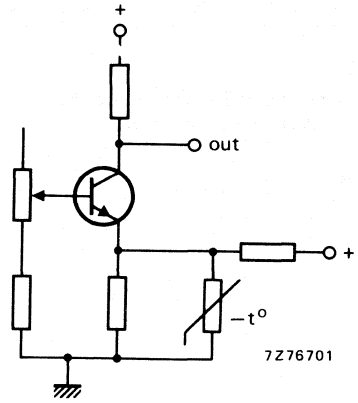

Fig. 25
Compensation of drift in field deflection coils.
The influence of the positive temperature
coefficient of the copper windings is compensated
by means of an NTC thermistor.

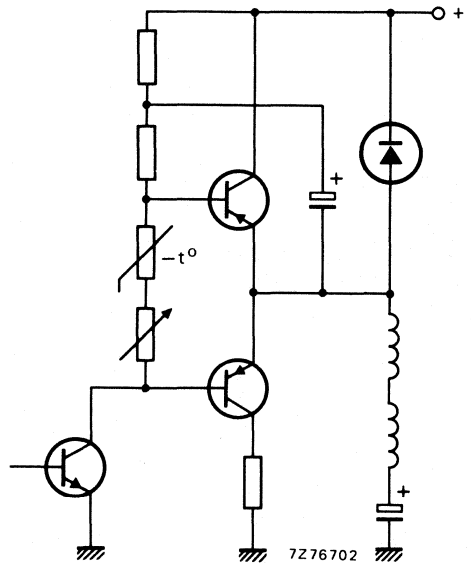

Fig. 26 Simple thermostat.

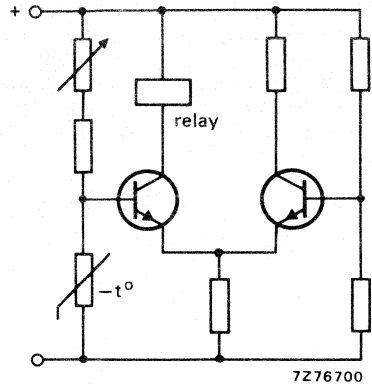
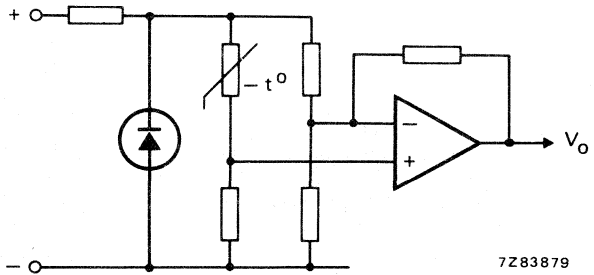

Fig. 27 Temperature sensing bridge with amplifier. The op-amp acts as difference amplifier. The sensitivity can be very high.



NTC THERMISTORS

Fig. 28 Basic temperature sensing configuration. The operational amplifier, e.g. type NE532, acts as a Schmitt trigger. The transfer characteristic is given in Fig. 29.

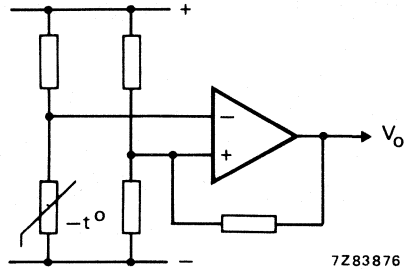

Fig. 29.

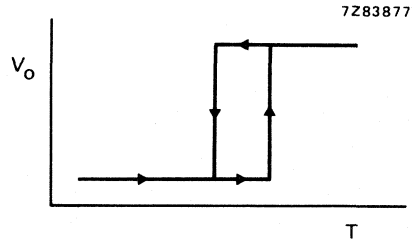

Fig. 30 Temperature controlled oscillator. This is a simple interface circuit for digital and microcomputer-controlled systems. The frequency of the output pulses is proportional to the temperature of the NTC thermistor. See Fig. 31.

$$f = \frac{1,49}{(R_{NTC} + 2R_B) C}$$

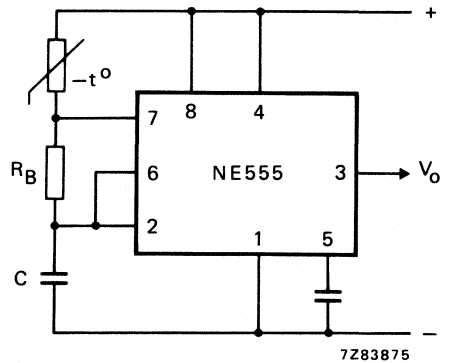
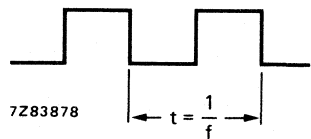

Fig. 31.



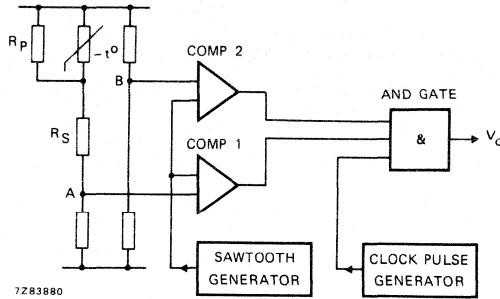

Fig. 32 Temperature sensing bridge with 0 °C offset and analogue to digital conversion. Due to R_P and R_S the voltage at point A varies linearly with the temperature of the NTC thermistor. The voltage at point B is equal to the voltage at point A when the temperature of the NTC thermistor is 0 °C. Both voltages are fed to the comparator circuit. See also Fig. 33.

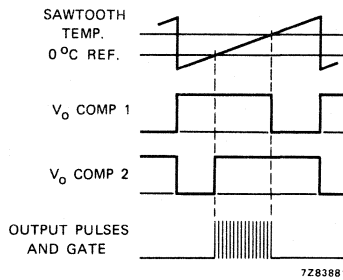
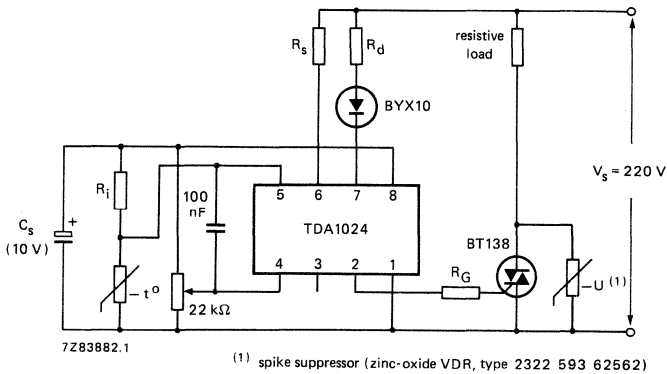

Fig. 33.



(1) spike suppressor (zinc-oxide VDR, type 2322 593 62562)

Fig. 34 Thermostat for room temperature control with a 2-point NTC thermistor as the sensing element. The TDA1024 triggers the triac during the zero crossings of the mains voltage only when the voltage across the NTC thermistor is higher than the voltage at the slider of the 22 kΩ potentiometer. (For complete information see our Technical Informations O10 and O25).

NTC THERMISTORS

disc

QUICK REFERENCE DATA

Resistance value at + 25 °C	4 to 1300 Ω
B _{25/85} -value	2800 to 5450 K
Maximum dissipation	1 W
Dissipation factor	10 mW/K
Thermal time constant	60 s approx.
Operating temperature range at zero power	-25 to +125 °C
at maximum power	0 to +55 °C

APPLICATION

General purpose.

DESCRIPTION

Disc thermistor with negative temperature coefficient with two tinned copper wires. It is not lacquered, not insulated and has a colour code.

MECHANICAL DATA

Outlines

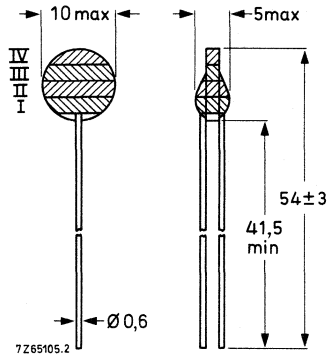

Fig. 1.

Marking (see Fig. 1)

The thermistors are marked with three colour bands showing their resistance value (R_{25}) in code as indicated in the table. Thermistors with a tolerance on R_{25} of 10% have a fourth band in silver.

Mass

1,0 to 1,3 g

Mounting

In any position by soldering.

Robustness of terminations

Tensile strength	10 N
Bending	5 N

Soldering

Solderability	max. 240 °C, max. 4 s
Resistance to heat	max. 240 °C, max. 4 s

PACKAGING

250 thermistors in a cardboard box.

ELECTRICAL DATA

Maximum dissipation *	1 W
Dissipation factor *	10 mW/K approx.
Thermal time constant *	60 s approx.
Heat capacity *	0,6 J/K approx.
Operating temperature at zero power	-25 to +125 °C
at maximum power	0 to +55 °C

See further Table 1.

* Measurements made in still air, between two phosphor-bronze wires (ϕ 1,3 mm).

Table 1 Catalogue numbers 2322 610 1....

suffix of catalogue number		R ₂₅ Ω	B _{25/85} ± 5% K	temperature coefficient %/K	colour code		
tol. ± 10%	tol. ± 20%				I	II	III
2408	1408	4	2800	-3,15	yellow	black	gold
2808	1808	8	2900	-3,25	grey	black	gold
2159	1159	15	3125	-3,40	brown	green	black
2339	1339	33	3250	-3,65	orange	orange	black
2509	1509	50	3300	-3,70	green	black	black
2131	1131	130	4600	-5,15	brown	orange	brown
2501	1501	500	5200	-5,85	green	black	brown
2132	1132	1300	5450	-6,15	brown	orange	red

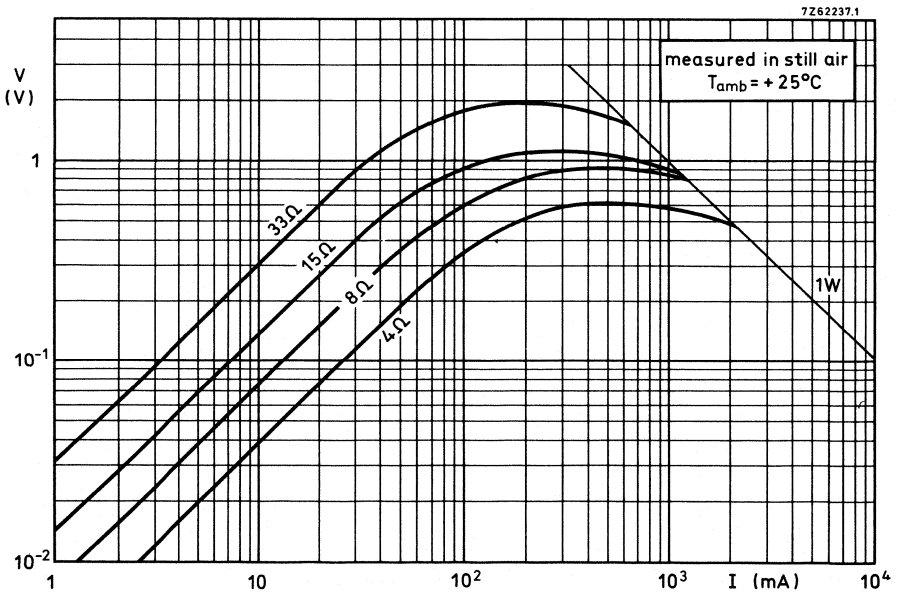
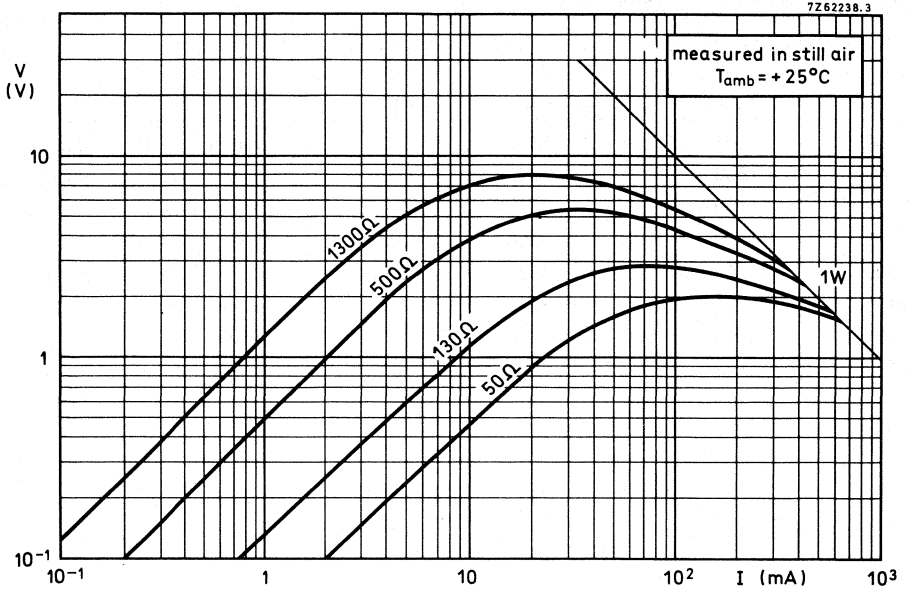

Fig. 2a and b Typical voltage/current characteristics.

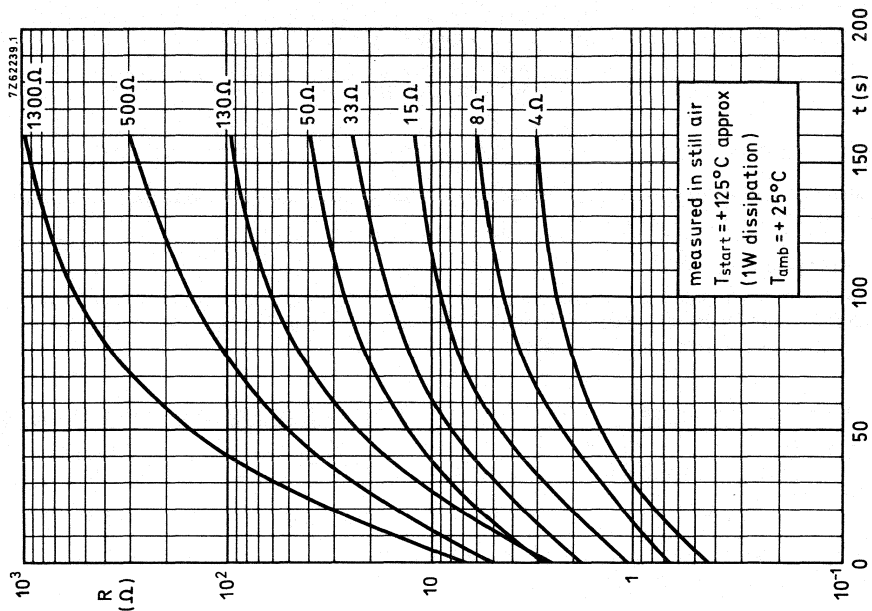

Fig. 4 Typical resistance/time (cooling) characteristics.

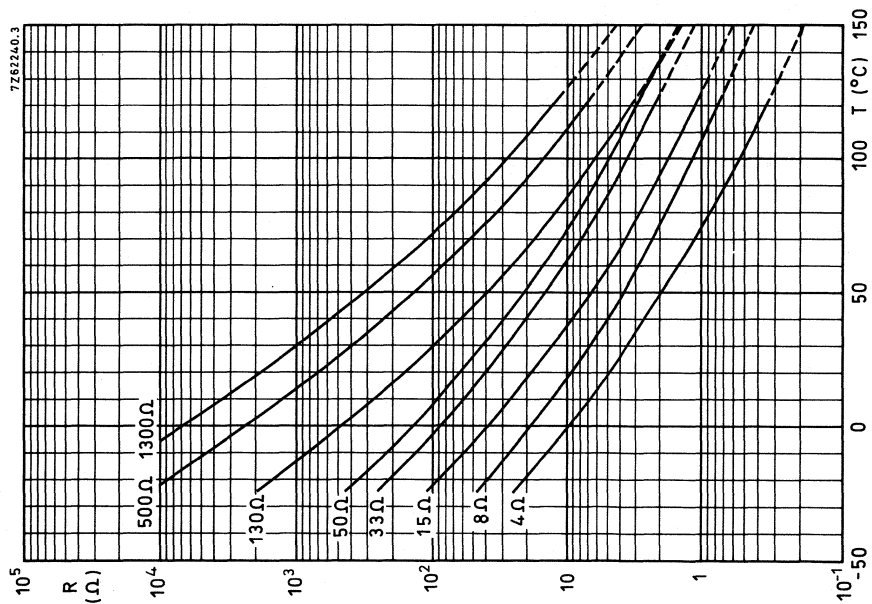

Fig. 3 Typical resistance/temperature characteristics.

NTC THERMISTORS

for motor cars

APPLICATION

Temperature sensing for the coolant in motor cars. They are also suitable for temperature control in household appliances, such as washing machines.

DESCRIPTION

Disc thermistors with negative temperature coefficient, without leads. They are specified at a medium temperature (25 °C) and at a higher temperature (100 °C), so that high accuracy at the working temperature is obtained (two-point sensor).

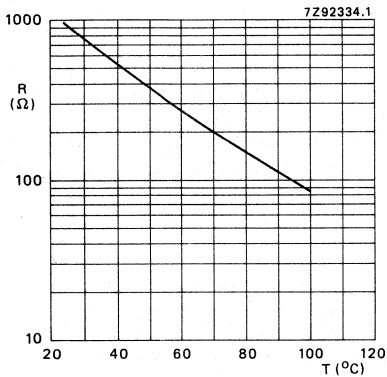

Catalogue number 2322 611 90027

Diameter $4,5 \pm 0,5$ mm

R25 $930 \Omega \pm 10\%$

R100 $84,5 \Omega \pm 7\%$

Typical resistance/temperature characteristics.

NTC THERMISTORS

miniature bead

QUICK REFERENCE DATA

Resistance value at + 25 °C	1 k Ω to 1 M Ω
B _{25/85} -value	2075 to 4100 K
Maximum dissipation	100 mW
Dissipation factor	~ 1,2 mW/K
Thermal time constant	~ 10 s
Operating temperature range	
at zero power	-25 to + 200 °C, or + 300 °C
at maximum power	0 to + 55 °C

APPLICATION

Temperature measurement and control up to 300 °C in 'aggressive' environments. Also level sensing. ←

DESCRIPTION

Bead thermistor with negative temperature coefficient, in a glass envelope with two tinned dumet (CuNiFe) wires.

MECHANICAL DATA

Outlines

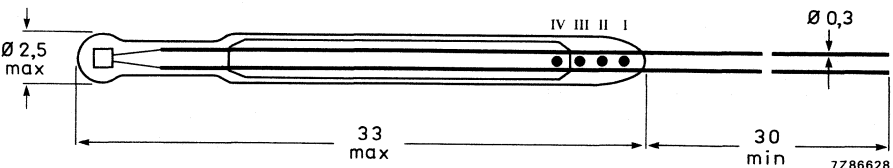

Fig. 1 Maximum bow in the centre of the glass envelope is 1 mm.

Marking

Four colour dots on the glass envelope, see table for colour code.

Mass

0,27 g approximately.

Mounting

In any position by soldering.

Soldering

Solderability max. 240 °C, max. 4 s
Resistance to heat max. 265 °C, max. 11 s

Inflammability

Uninflammable.

Impact

Free fall 100 mm

Robustness of terminations

Tensile strength 2,5 N
 Bending 1,25 N
 Resistance to solvents according to IEC 68-2-45, resistant to R113 at T_{amb}.

PACKAGING

100 thermistors in a cardboard box.

ELECTRICAL DATA

Unless otherwise specified, measured according to IEC publication 539.

Table 1 Catalogue number 2322 626 1....

suffix of the catalogue number			R ₂₅ kΩ	B _{25/85} -value ± 5% K	temperature coefficient at 25 °C %/K	colour code*		
tol. ± 5%	tol. ± 10%	tol. ± 20%				I	II	III
3102	2102	1102	1	2075	-2,3	brown	black	red
3222	2222	1222	2,2	2285	-2,6	red	red	red
3472	2472	1472	4,7	2485	-2,8	yellow	violet	red
3103	2103	1103	10	2750	-4,2	brown	black	orange
3223	2223	1223	22	3560	-4,0	red	red	orange
3473	2473	1473	47	3750	-4,2	yellow	violet	orange
3104	2104	1104	100	3900	-4,4	brown	black	yellow
3224	2224	1224	220	3860	-4,3	red	red	yellow
3474	2474	1474	470	3950	-4,5	yellow	violet	yellow
3105	2105	1105	1000	4100	-4,6	brown	black	green

* Thermistors with 5% tolerance have a gold dot IV; 10% tolerance is identified by a silver dot IV, 20% versions have no dot IV (Fig. 1).

Maximum dissipation at + 55 °C 100 mW
 Dissipation factor ~ 1,2 mW/K
 Thermal time constant ~ 10 s
 Response time (see note) ~ 1 s
 Operating temperature range (Fig. 2 and Table 1)
 at zero power -25 to + 200 °C, or + 300 °C
 at maximum power 0 to + 55 °C
 Dielectric withstanding voltage (r.m.s.)
 between terminals and glass envelope min. 1500 V
 Insulation resistance between terminals
 and glass envelope at 100 V (d.c.) min. 100 MΩ

Note: Response time in silicone oil MS 200/50. The response time in silicone oil is the time necessary to change of 63,2 % of the total difference between the initial and the final body temperature, when subjected to a step function change in ambient temperature. Step change: initial temperature: air at 25 °C; final temperature: oil (MS 200/50) at 85 °C.

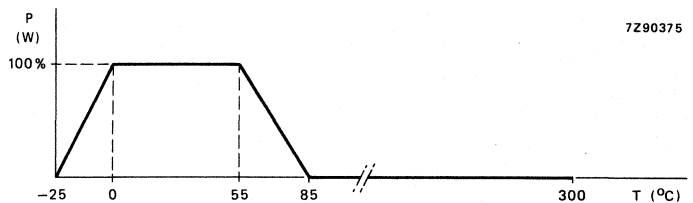

Fig. 2 Derating curve.

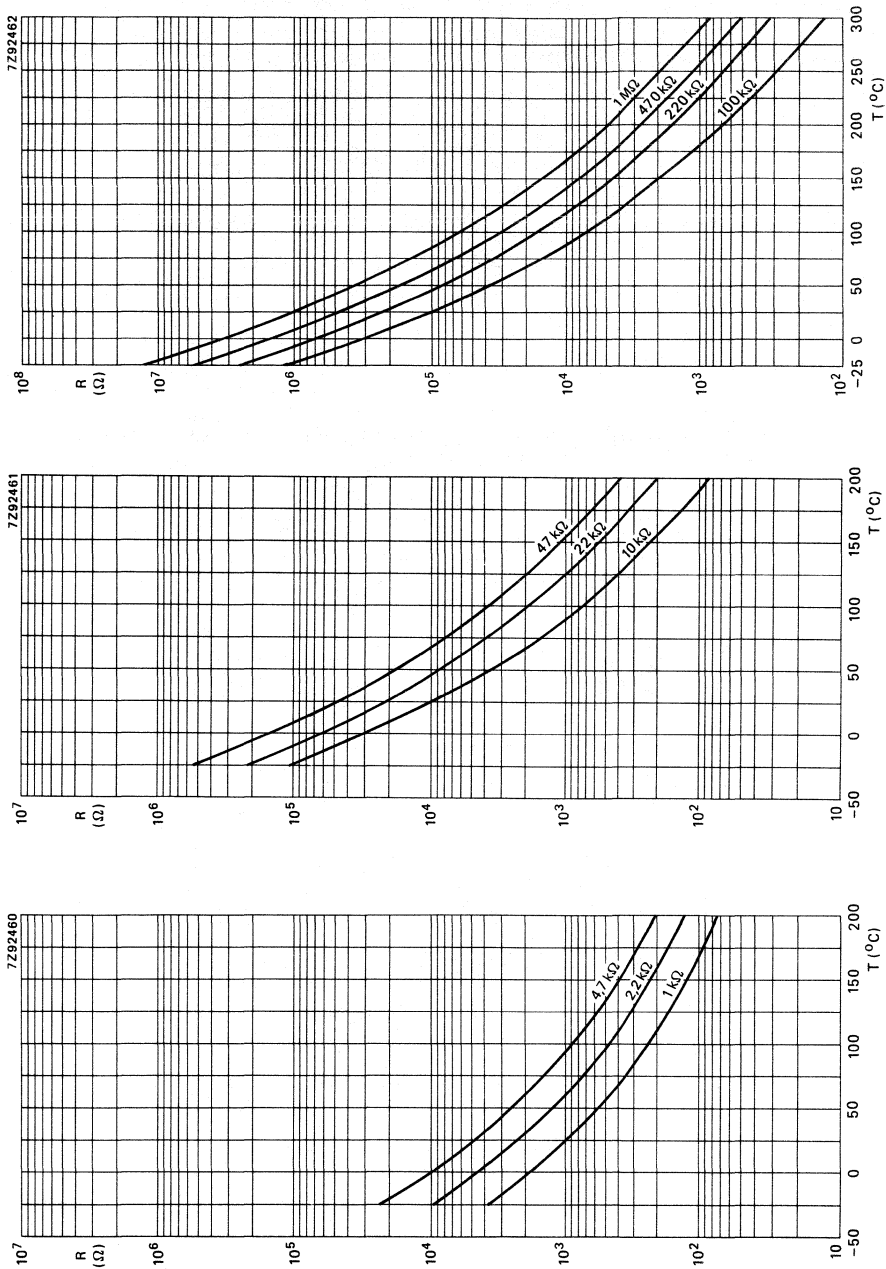

Fig. 3 Typical resistance/temperature characteristics.

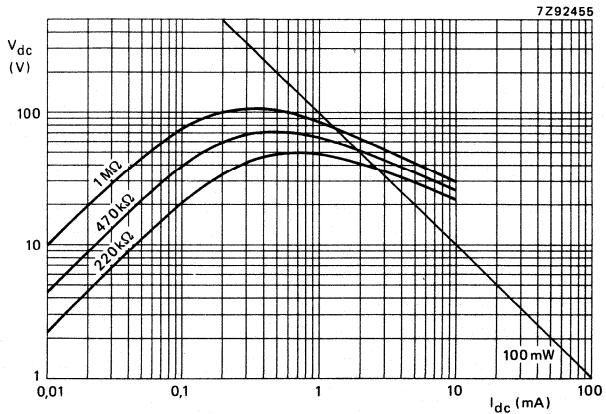
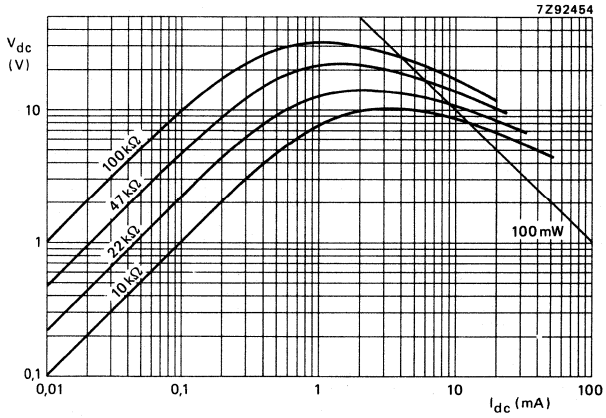
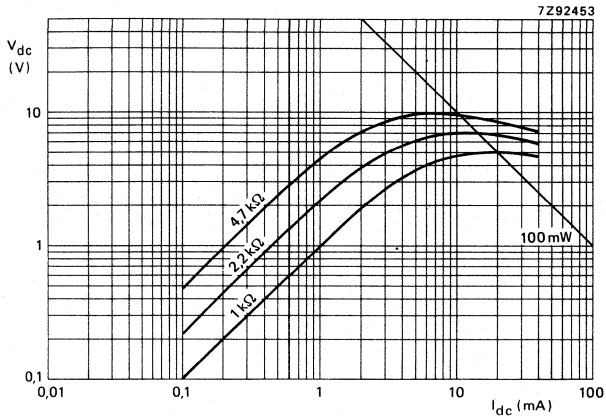

Fig. 4 Typical voltage/current characteristics. Measured in still air at 25 °C.

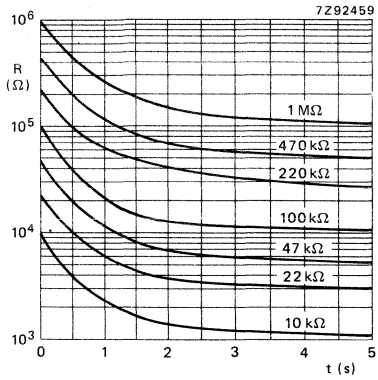
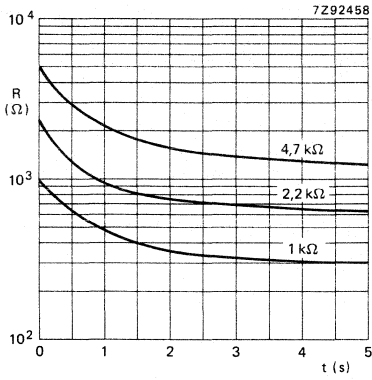

Fig. 5 Typical resistance/response characteristics.
Temperature step from air at 25 °C to oil at 85 °C.

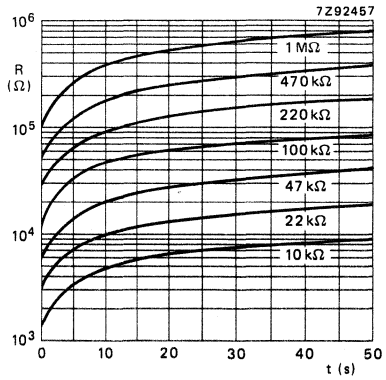
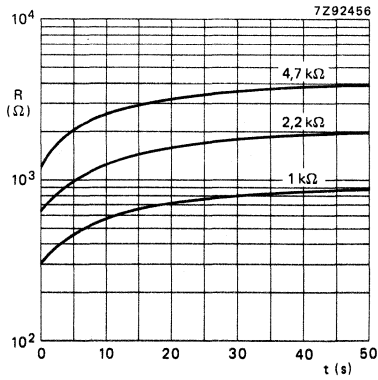

Fig. 6 Typical resistance/cooling time characteristics.
Measured in still air at 25 °C. $T_{start} = 85$ °C.

NTC THERMISTORS

miniature bead

QUICK REFERENCE DATA

Resistance value at + 25 °C	1 k Ω to 1 M Ω
B _{25/85} -value	2075 to 4100 K
Maximum dissipation	100 mW
Dissipation factor	~ 0,8 mW/K
Thermal time constant	~ 7,5 s
Operating temperature range at zero power	-55 to + 200 °C or + 300 °C
at maximum power	0 to + 55 °C

APPLICATION

Temperature measurement and control up to 300 °C. Also level sensing. ←

DESCRIPTION

Bead thermistor with negative temperature coefficient, in a glass envelope with two tinned dumet (CuNiFe) wires.

MECHANICAL DATA

Outlines

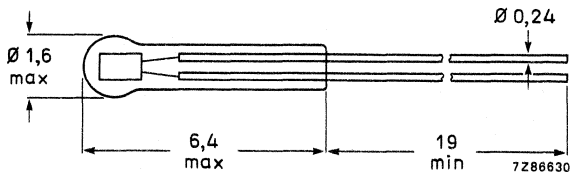

Fig. 1.

Marking

None

Mass

33 mg approximately

Mounting

In any position by soldering.

Soldering

Solderability max. 240 °C, max. 4 s
Resistance to heat max. 265 °C, max. 11 s

Inflammability

Uninflammable

Impact

Free fall 100 mm

Robustness of terminations

Tensile strength 1,0 N

PACKAGING

100 thermistors in a cardboard box.

ELECTRICAL DATA

Unless otherwise specified, measured according to IEC publication 539.

Table 1 Catalogue number 2322 626 2....

suffix of the catalogue number			R ₂₅ kΩ	B _{25/85} -value ± 5% K	T _{max} °C	temperature coefficient at 25 °C %/K
tol. ± 5%	tol. ± 10%	tol. ± 20%				
3102	2102	1102	1	2075	200	-2,3
3222	2222	1222	2,2	2285	200	-2,6
3472	2472	1472	4,7	2485	200	-2,8
3103	2103	1103	10	3750	200	-4,2
3223	2223	1223	22	3560	200	-4,0
3473	2473	1473	47	3750	200	-4,2
3104	2104	1104	100	3900	300	-4,4
3224	2224	1224	220	3860	300	-4,3
3474	2474	1474	470	3950	300	-4,5
3105	2105	1105	1000	4100	300	-4,6

Maximum dissipation at + 55 °C

100 mW

Dissipation factor

~ 0,8 mW/K

Thermal time constant

~ 7,5 s

Response time (see note)

~ 0,85 s

Operating temperature range (Fig. 2 and Table 1)

at zero power

-55 to + 200 °C, or + 300 °C

at maximum power

0 to + 55 °C

Dielectric withstanding voltage (r.m.s.)

between terminals and glass envelope

min. 100 V

Insulation resistance between terminals

and glass envelope at 10 V (d.c.)

min. 10 MΩ

Note: Response time in silicone oil MS 200/50. The response time in silicone oil is the time necessary to change of 63,2 % of the total difference between the initial and the final body temperature, when subjected to a step function change in ambient temperature. Step change: initial temperature: air at 25 °C; final temperature: oil (MS 200/50) at 85 °C.

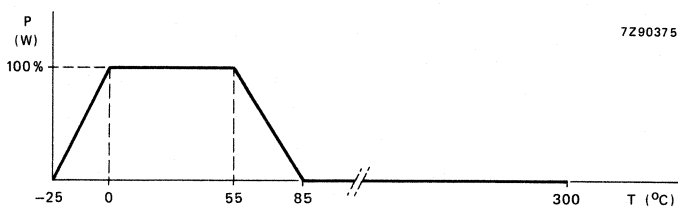

Fig. 2 Derating curve.

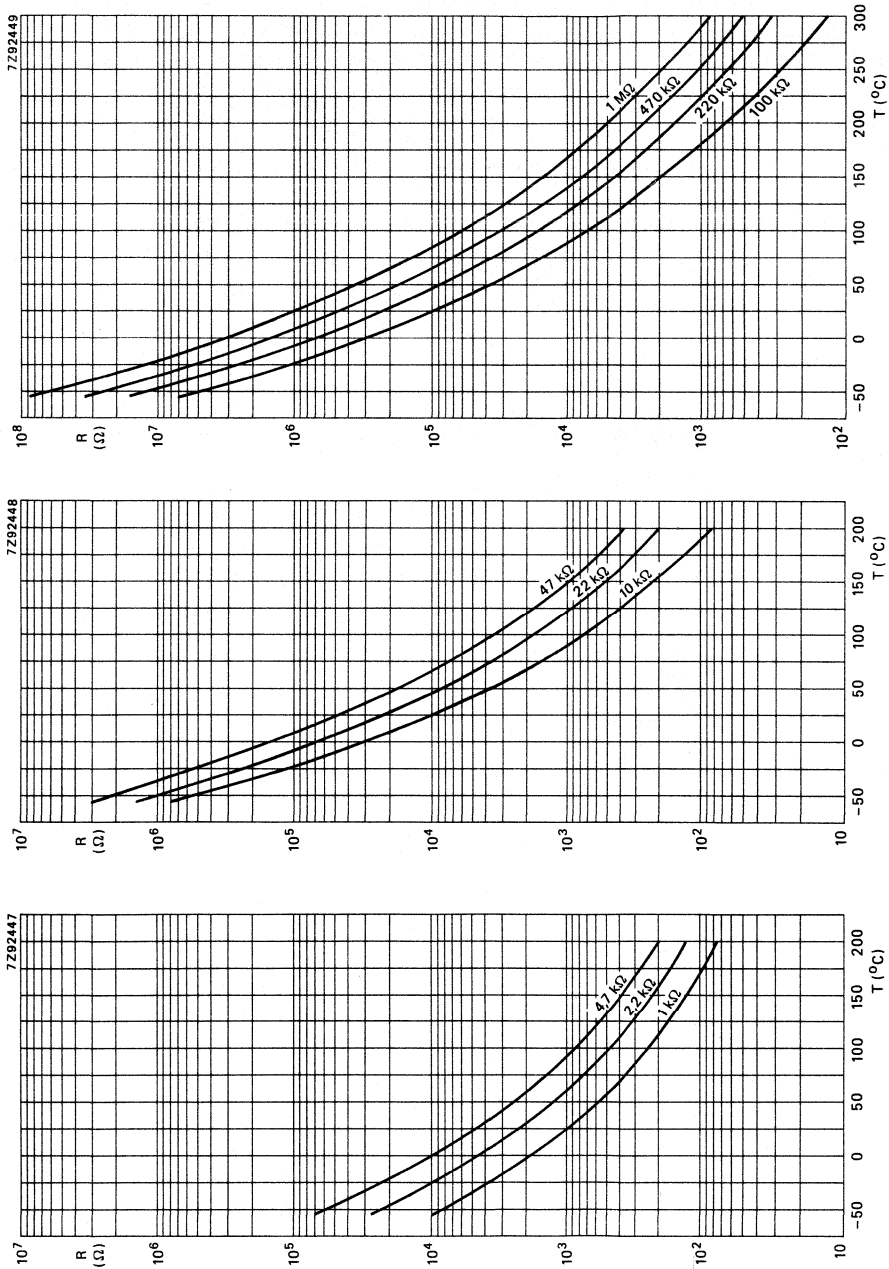

Fig. 3 Typical resistance/temperature characteristics.

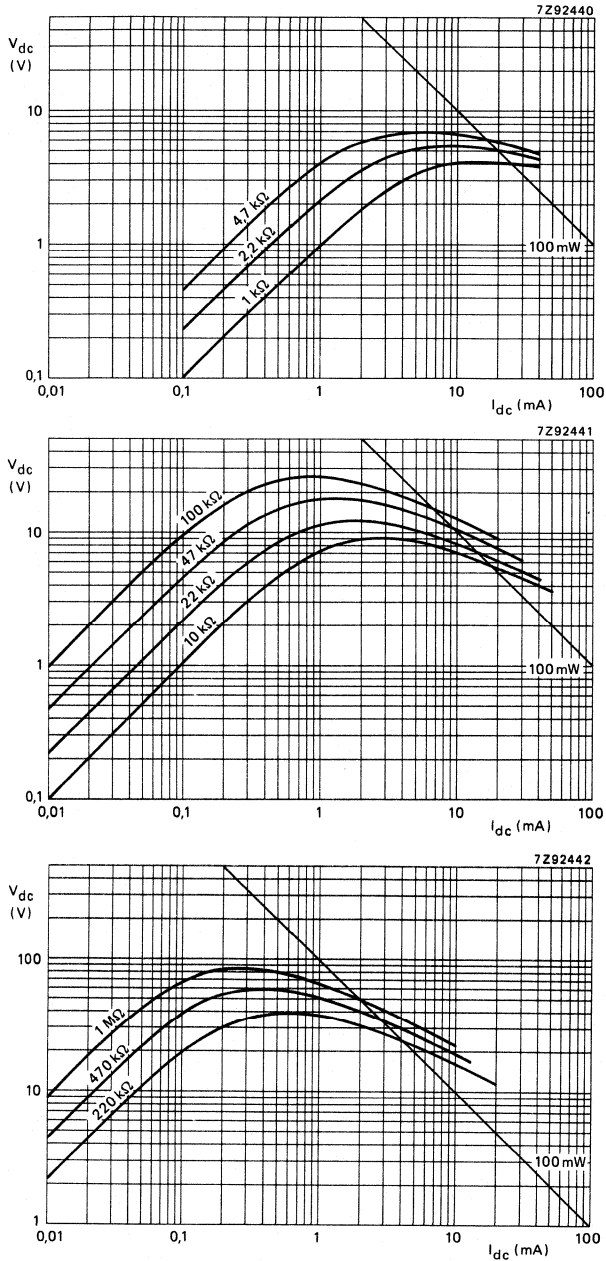

Fig. 4 Typical voltage/current characteristics. Measured in still air at 25 °C.

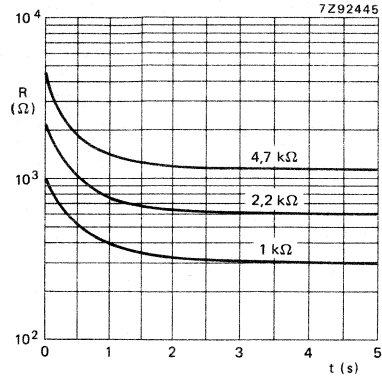
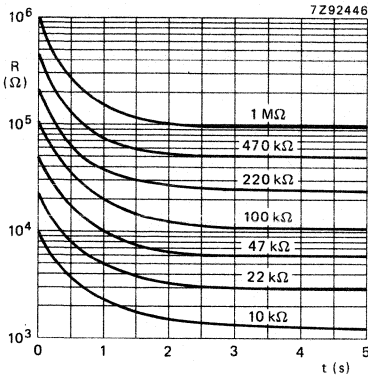

Fig. 5 Typical resistance/response characteristics.
Temperature step from air at 25 °C to oil at 85 °C.

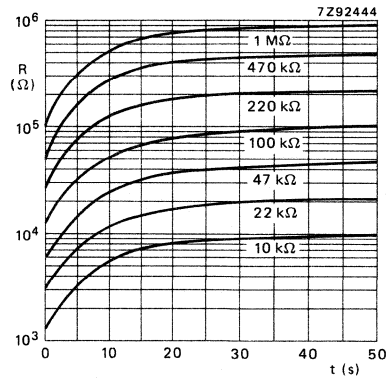
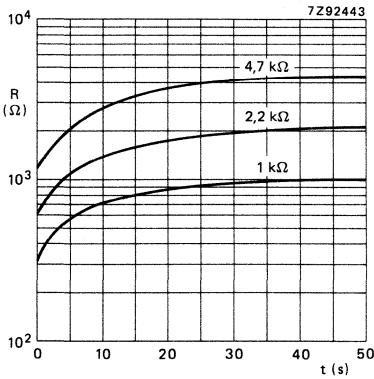

Fig. 6 Typical resistance/cooling time characteristics.
Measured in still air at 25 °C. $T_{start} = 85$ °C.

NTC THERMISTOR

indirectly heated

QUICK REFERENCE DATA

Resistance at +25 °C	15 k Ω
Resistance of heater	200 Ω
B _{25/85} value	3860 K
Maximum dissipation of thermistor at $W_H = 0$ mW	15 mW
Operating temperature range	-25 to +85 °C

APPLICATION

Compensation in telecommunication amplifiers.

DESCRIPTION

Miniature thermistor with negative temperature coefficient, indirectly heated and vacuum mounted in a glass bulb.

MECHANICAL DATA

Unless otherwise specified, measured according to IEC80.

Outlines

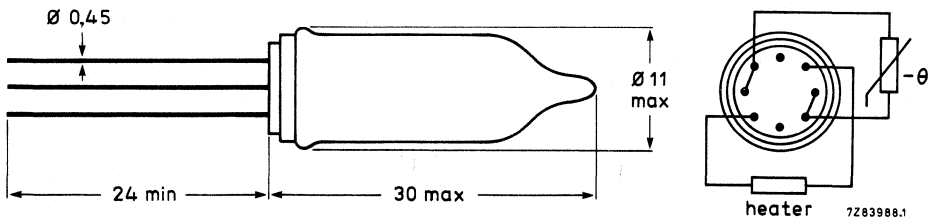

Marking

R₁₇ (± 2,5 %) and ratio R_{g,5}/R₁₇ (± 5%).

Mass

1,8 g approximately.

Mounting

In any position by soldering.

Robustness of terminations

Tensile strength 5 N
Bending 2,5 N

Soldering

Solderability max. 240 °C, max. 4 s
Resistance to heat max. 265 °C, max. 11 s.

Vibration

Severity 55 A

Impact

Shock severity 50 A
 Bump severity 40 A/4000
 Free fall 100 mm

The terminal wires are tinned to max. 2 mm from the glass body, the wires of the heater are provided with a red sleeve.

ELECTRICAL DATA

Unless otherwise specified, measured according to IEC draft 40/043/74 of January 1977.

$R_{25} \pm 30\%$	15	$k\Omega$
Maximum resistance at 25 °C and $I_h = 17$ mA	55	Ω
Minimum ratio $R_{9,5}/R_{17}$	7,5	
$R_h \pm 6\%$	200	Ω
B _{25/85}	3860	K
Temperature coefficient at +25 °C	~	-4,35 %/K
Maximum dissipation at zero power of heater ($W_h = 0$)	15	mW
of thermistor ($W_{th} = 0$)	65	mW
Maximum peak dissipation, $W_{th} = 0$	80	mW
Maximum capacitance between heater and thermistor at 1 MHz	6	pF
Operating temperature range	-25 to +85 °C	
Derating curve:		

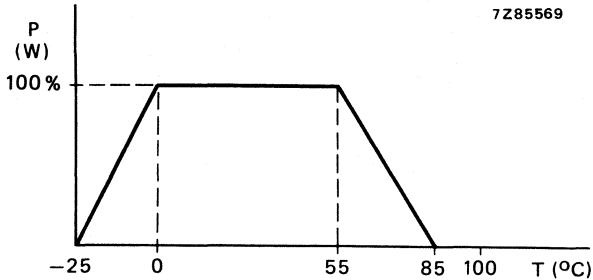

Dielectric withstanding voltage between terminals of thermistor and heater	min. 15 V
Insulation resistance at 10 V (d.c.) and $I_h = 18$ mA, between terminals of thermistor and heater	min. 5 M Ω

PACKAGING

200 per cardboard box

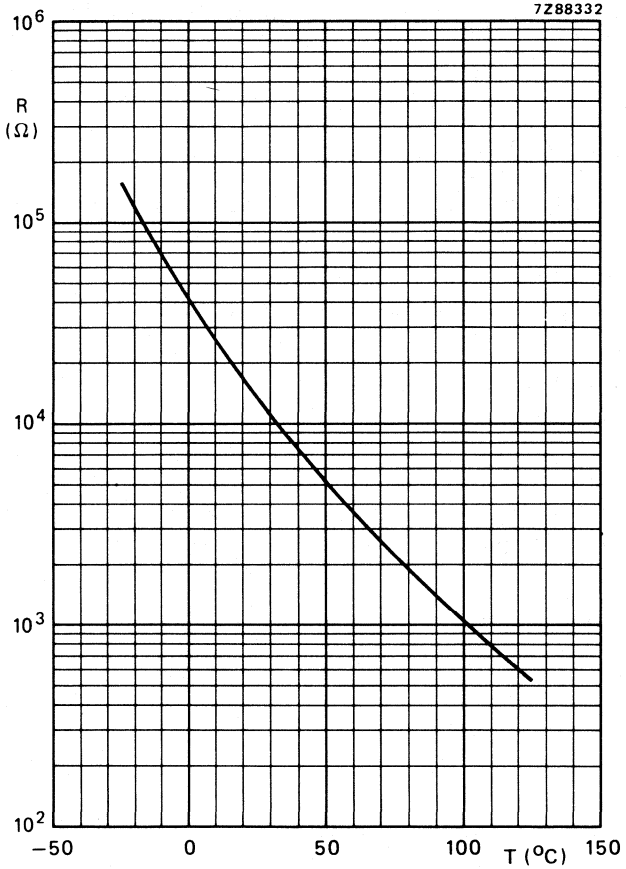

Typical resistance/temperature characteristic.

NTC THERMISTORS miniature bead

QUICK REFERENCE DATA

Resistance value at + 25 °C	1 k Ω to 1 M Ω
B _{25/85} -value	2075 to 4100 K
Operating temperature range at zero power	-55 to + 200 °C

APPLICATION

Temperature measurement, level and flow sensing. ←

DESCRIPTION

Bead thermistor with negative temperature coefficient, with two solid platinum-iridium leads in opposition or in same direction.

MECHANICAL DATA

Outlines

Fig. 1
version 2322 633 0....

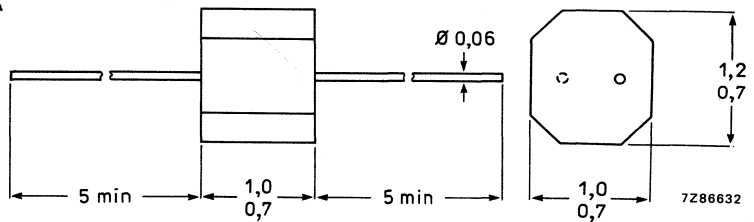
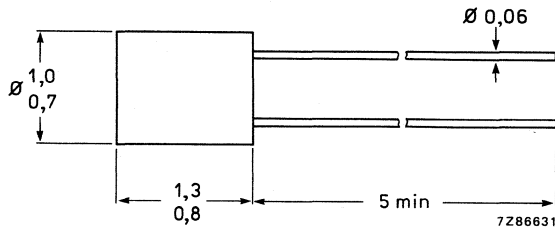

Fig. 2
version 2322 633 1....



Marking
none.

Mounting
In any position by spot welding of the leads to conducting wires or other supports.

Mass
5 mg. approximately.

Inflammability
Uninflammable.

PACKAGING

100 thermistors in a cardboard box.

2322 633 0....
2322 633 1....

ELECTRICAL DATA

Unless otherwise specified, measured according to IEC publication 539.

catalogue number				R ₂₅	temperature [±] coefficient at 25 °C	B _{25/85} -value ± 5%
2322 633 0.... leads in opposition		2322 633 1.... leads in same direction				
tol. ± 5%	tol. ± 10%	tol. ± 5%	tol. ± 10%	kΩ	%/K	K
3102	2102	3102	2102	1	-2,3	2075
3222	2222	3222	2222	2,2	-2,6	2285
3472	2472	3472	2472	4,7	-2,8	2485
3103	2103	3103	2103	10	-4,2	3750
3223	2223	3223	2223	22	-4,0	3560
3473	2473	3473	2473	47	-4,2	3750
3104	2104	3104	2104	100	-4,4	3900
3224	2224	3224	2224	220	-4,1	3860
3474	2474	3474	2474	470	-4,5	3950
3105	2105	3105	2105	1000	-4,6	4100

Operating temperature range, at zero power

-55 to +200 °C

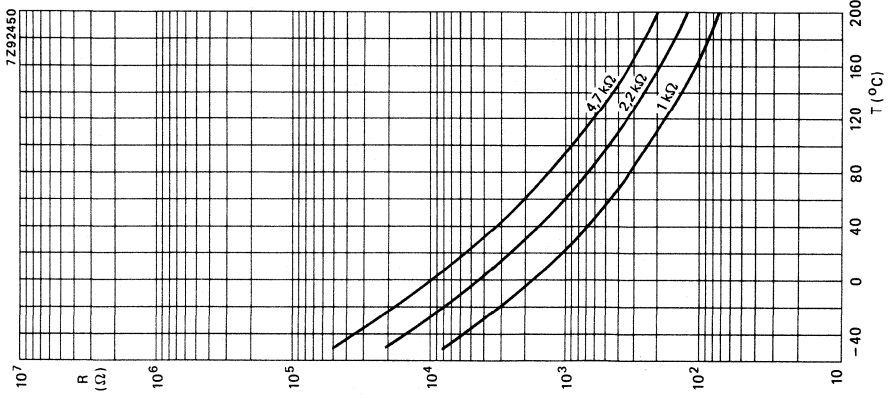
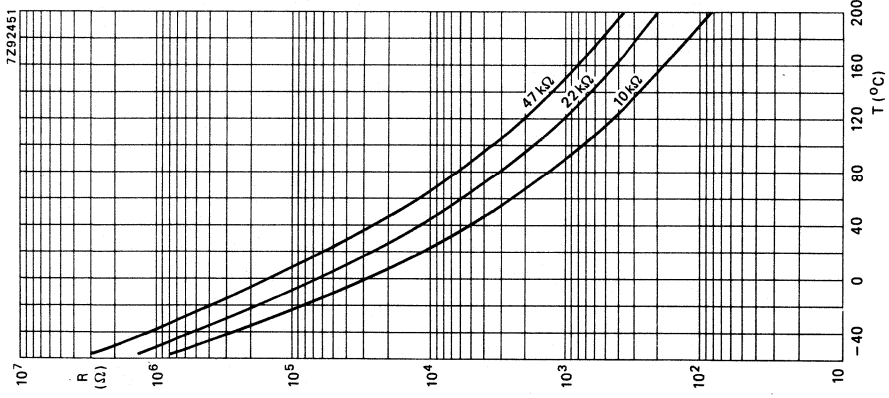
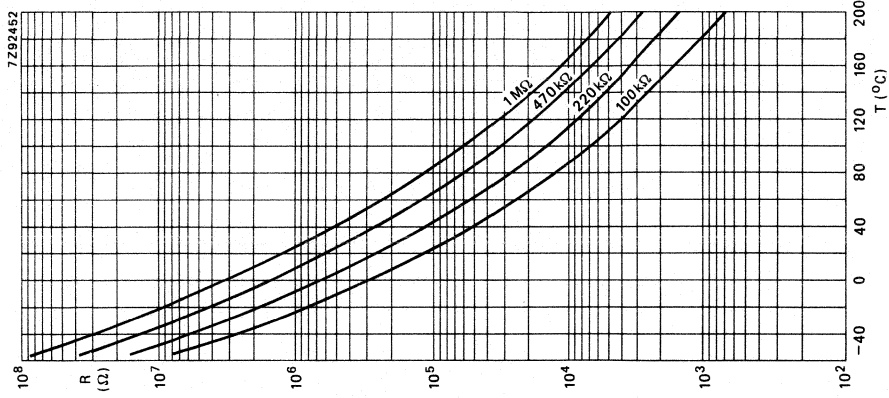

Fig. 3 Typical resistance/temperature characteristics.

NTC THERMISTORS

miniature bead

QUICK REFERENCE DATA

Resistance value at + 25 °C	1 k Ω to 1 M Ω
B25/85-value	2075 to 4100 K
Maximum dissipation	60 mW
Dissipation factor	~ 0,5 mW/K
Thermal time constant	~ 5,5 s
Operating temperature range at zero power	-55 to + 200 °C
at maximum power	0 to + 55 °C

APPLICATION

Temperature measurements.

DESCRIPTION

Bead thermistor with negative temperature coefficient, in a glass envelope with two tinned dumet (CuNiFe) wires.

MECHANICAL DATA

Outlines

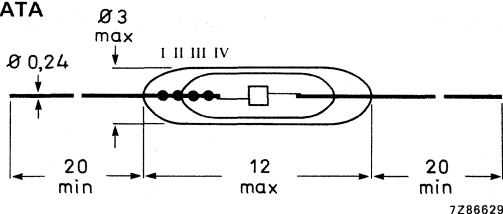

Fig. 1.

Marking

Colour dots on the glass envelope, see Fig. 1 and Table 1.

Mass

0,1 g approximately.

Mounting

In any position by soldering.

Soldering

Solderability max. 240 °C, max. 4 s
Resistance to heat max. 265 °C, max. 11 s

Inflammability

Uninflammable.

Impact

Free fall 100 mm

Robustness of terminations

Tensile strength 1,0 N
 Bending 0,5 N
 Torsion 3 times

Resistance to solvents: according to IEC 68-2-45, resistant to R113 at T_{amb}

Packaging

100 thermistors in a cardboard box.

ELECTRICAL DATA

Unless otherwise specified, measured according to IEC publication 539.

Table 1 Catalogue number 2322 633 2....

suffix of the catalogue number			R ₂₅	B _{25/85} -value ± 5%	temperature coefficient at 25 °C %/K	colour code*		
tol. ± 5%	tol. ± 10%	tol. ± 20%	kΩ	K		I	II	III
3102	2102	1102	1	2075	-2,3	brown	black	red
3222	2222	1222	2,2	2285	-2,6	red	red	red
3472	2472	1472	4,7	2485	-2,8	yellow	violet	red
3103	2103	1103	10	3750	-4,2	brown	black	orange
3223	2223	1223	22	3560	-4,0	red	red	orange
3473	2473	1473	47	3750	-4,2	yellow	violet	orange
3104	2104	1104	100	3900	-4,4	brown	black	yellow
3224	2224	1224	220	3860	-4,3	red	red	yellow
3474	2474	1474	470	3950	-4,5	yellow	violet	yellow
3105	2105	1105	1000	4100	-4,6	brown	black	green

* Thermistors with 5% tolerance have a gold dot IV; 10% tolerance is identified by a silver dot IV, 20% versions have no dot IV (Fig. 1).

- Maximum dissipation at + 55 °C 60 mW
- Dissipation factor ~ 0,5 mW/K
- Thermal time constant ~ 5,5 s
- Operating temperature range (Fig. 2)
 - at zero power -55 to + 200 °C
 - at maximum power 0 to + 55 °C
- Dielectric withstanding voltage (r.m.s.)
 between terminals and glass envelope min. 1500 V
- Insulation resistance between terminals
 and glass envelope at 100 V (d.c.) min. 100 MΩ

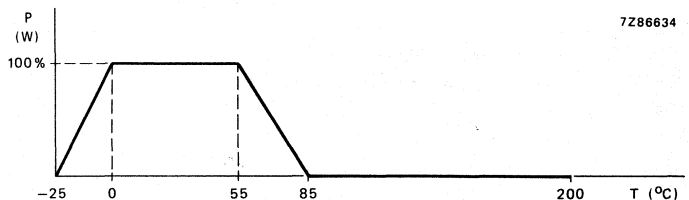

Fig. 2 Derating curve.

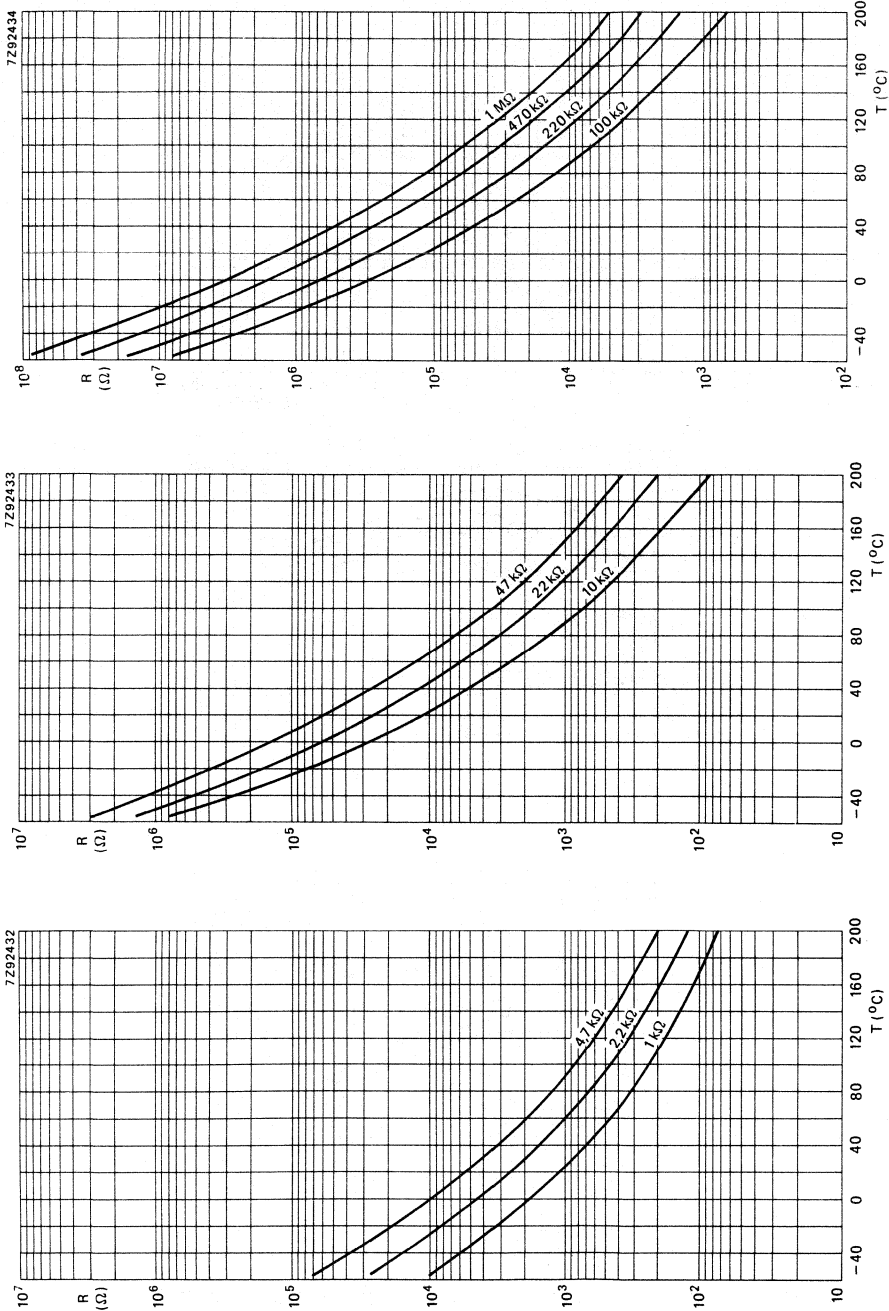

Fig. 3 Typical resistance/temperature characteristics.

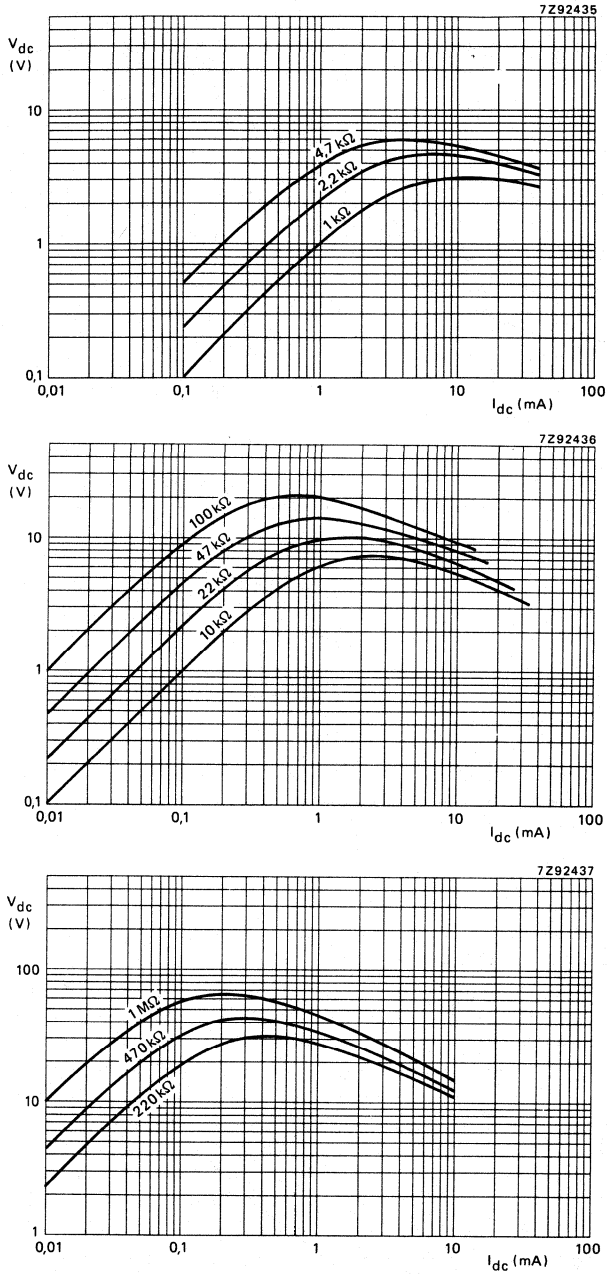

Fig. 4 Typical voltage/current characteristic. Measured in still air at 25 °C.

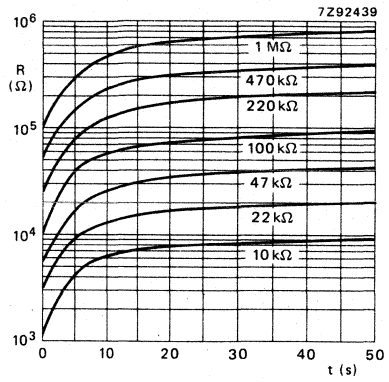
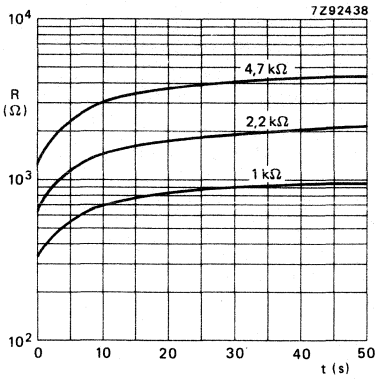

Fig. 5 Typical resistance/cooling characteristics.
 Measured in still air at 25 °C. $T_{start} = 85$ °C.

DEVELOPMENT DATA

This data sheet contains advance information and specifications are subject to change without notice.

2322 633 72224
2322 633 73224

NTC THERMISTORS

QUICK REFERENCE DATA

Type	2322 633	72224	73224
Resistance at 25 °C	220 k Ω	$\pm 10\%$	$\pm 5\%$
Maximum dissipation		100	mW
Operating temperature range			
at zero power		25 to 300	°C
at maximum power		25 to 55	°C

APPLICATION

For high temperature measurement and control in domestic appliances and industrial process control equipment.

DESCRIPTION

These thermistors have a negative temperature coefficient and are mounted in a glass envelope (SOD-27). They have two nickel plated copper clad iron connecting leads.

MECHANICAL DATA

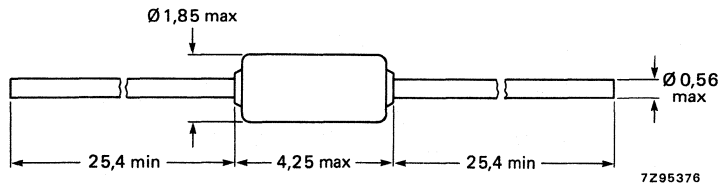

Fig. 1.

- Marking** : none
- Mass** : 0,14 g approximately
- Mounting** : in any position by soldering
- Resistance to solvents** : according to IEC 68-2-45

Robustness of terminations

tensile strength	10 N
bending	5 N
torsion	3 times

Soldering

Solderability	max. 240 °C	max. 4 s
Resistance to heat	max. 265 °C	max. 11 s

For operating temperatures up to 300 °C spot welding is preferred.

2322 633 72224
2322 633 73224

Impact

Free fall

100 mm

Inflammability

not inflammable, according to IEC 695-2-2

Packaging

500 thermistors in a cardboard box.

ELECTRICAL DATA

Unless otherwise specified, measured according to IEC publication 539.

Resistance at 25 °C

type 2322 633 72224

220 kΩ ± 10%

type 2322 633 73224

220 kΩ ± 5%

B25/85 value

3797 K ± 3%

Maximum dissipation

100 mW

Operating temperature range

at zero power

25 to 300 °C

at maximum power

25 to 55 °C

Derating

See Fig. 2.

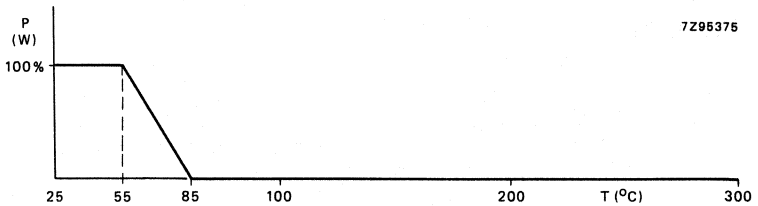

Fig. 2 Derating curve.

Dry heat at 300 °C, steady state

max. 1000 h

Rapid change of temperature, 30 S at 25 °C/15 S at 300 °C

50 000 cycles

For resistance versus temperature See Table 1

Resistance versus temperature

Table 1

temperature °C	resistance Ω	2322 633 72224 tolerance on R		2322 633 73224 tolerance on R		temp. coefficient %/K
		+ %	- %	+ %	- %	
25	220 000	10,00	10,00	5,00	5,00	-4,12
30	179 500	10,61	10,61	5,61	5,61	-4,02
40	121 300	11,80	11,76	6,80	6,76	-3,81
50	83 630	12,94	12,58	7,94	7,58	-3,63
60	58 710	14,04	13,88	9,04	8,88	-3,45
70	41 920	15,10	14,84	10,10	9,84	-3,29
80	30 410	16,12	15,75	11,12	10,75	-3,13
90	22 390	17,10	16,65	12,10	11,65	-2,99
100	16 720	18,01	17,41	13,01	12,41	-2,87
110	12 630	18,95	18,23	13,95	13,23	-2,74
120	9 663	19,83	18,95	14,83	13,95	-2,62
130	7 478	20,68	19,64	15,68	14,64	-2,51
140	5 851	21,50	20,32	16,50	15,32	-2,40
150	4 625	22,28	20,94	17,28	15,94	-2,30
160	3 691	23,06	21,54	18,06	16,54	-2,21
170	2 973	23,79	22,14	18,79	17,14	-2,12
180	2 415	24,49	22,67	19,49	17,67	-2,04
190	1 978	25,17	23,20	20,17	18,20	-1,96
200	1 632	25,87	23,66	20,87	18,66	-1,90
210	1 355	26,46	24,17	21,46	19,17	-1,83
220	1 132	27,14	24,60	22,14	19,60	-1,76
230	952	27,70	25,07	22,70	20,07	-1,70
240	806	28,32	25,48	23,32	20,48	-1,64
250	686	28,90	25,90	23,90	20,90	-1,58
260	587	29,45	26,42	24,45	21,42	-1,53
270	506	29,99	26,67	24,99	21,67	-1,47
280	437	30,50	27,03	25,50	22,03	-1,43
290	380	31,02	27,36	26,02	22,36	-1,38
300	332	31,50	27,72	26,50	22,72	-1,33

APPLICATION EXAMPLE

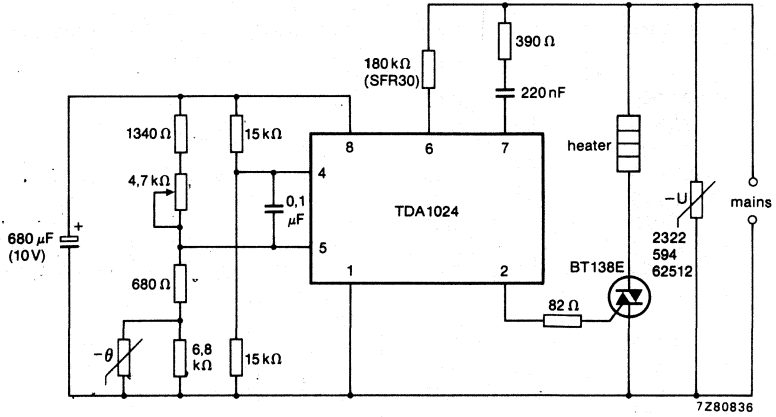

Fig. 3 Temperature control circuit for flat irons, chip pans etc.
The temperature range is 80 °C to 280 °C. On/off control with 'zero crossing' switching.

DEVELOPMENT DATA

This data sheet contains advance information and specifications are subject to change without notice.

2322 636 90018

NTC THERMISTOR

QUICK REFERENCE DATA

Resistance at 25 °C	150 k Ω \pm 20 %
B _{25/85} value	4200 K \pm 5 %
Maximum dissipation	0,5 W
Operating temperature range	
at zero power	-25 to 125 °C
at maximum power	0 to 55 °C

APPLICATION

For use in the e.h.t. lead of colour television sets.

DESCRIPTION

This thermistor has a negative temperature coefficient. It consists of a rod with two axial tinned solid copper wires and a shrink sleeve.

MECHANICAL DATA

Outlines

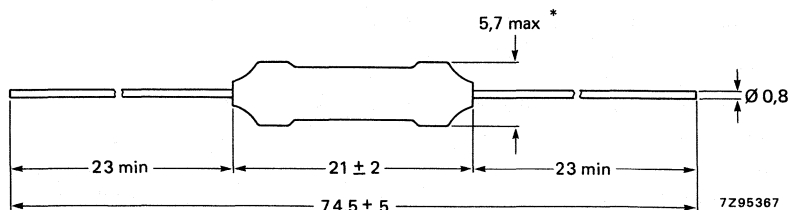

Fig. 1.

* The thermistors are required to pass through a control gauge dimensioned as per Fig. 2.

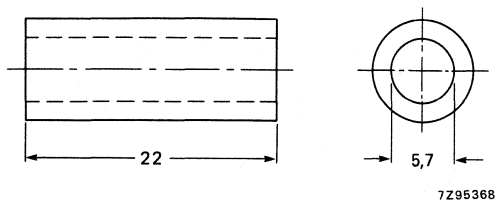

Fig. 2.

MECHANICAL DATA (continued)

Marking : none

Mass : approx. 1,4 g

Mounting : in any position by soldering

Robustness of terminations

tensile strength	10 N
bending	5 N
torsion	3 times

Soldering

Solderability	max. 240 °C, max. 4 s
Resistance to heat	max. 265 °C, max. 11 s

Impact

Free fall 1000 mm

Resistance to solvents

The thermistors is resistant to all cleaning solvents according to IEC 68-2-45.

Inflammability

Non inflammable according to IEC 695-2-2 (1980, needle flame).

PACKAGING

The thermistors are packed in cardboard boxes of 500.

ELECTRICAL DATA

Unless otherwise specified, measured according to IEC publication 539 of 1976

Resistance at 25 °C	150 kΩ ± 20%
B25/85 value	4200 K ± 5%
Temperature coefficient	- 4,7 %/K
Maximum dissipation	0,5 W
Flash-over test, see Fig. 3	min. 27 kV

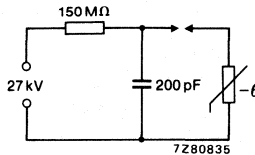

Fig. 3.

Operating temperature range at
zero power
maximum power, see Fig. 4

-25 to 125 °C
0 to 55 °C

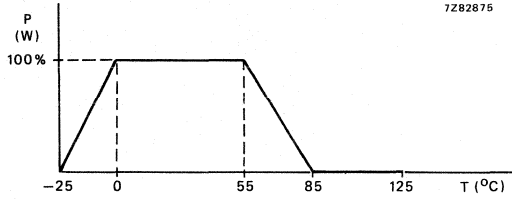

Fig. 4 Derating curve.

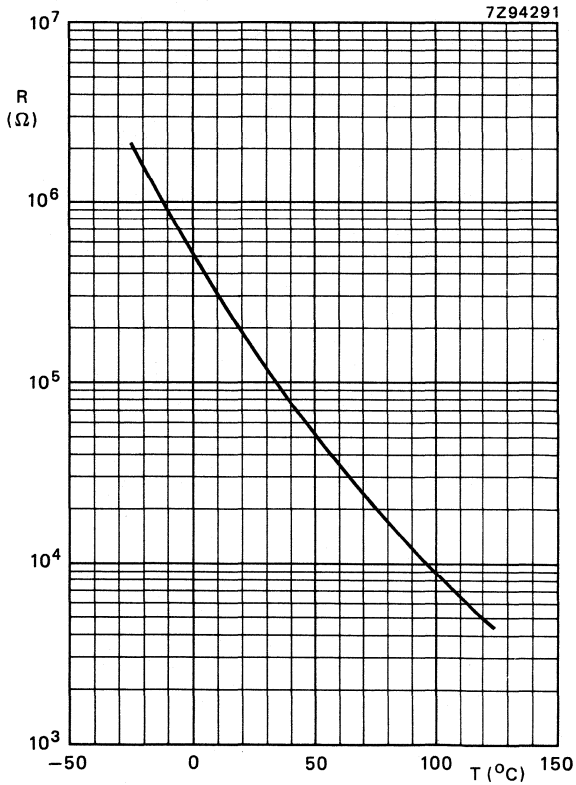

Fig. 5 Typical resistance/temperature characteristic.

NTC THERMISTORS

QUICK REFERENCE DATA

Resistance value at +25 °C	2,7 to 330 k Ω	
B _{25/85} value	3660 to 4150 K	
Maximum dissipation	0,25 W	
Dissipation factor	7 mW/K	←
Thermal time constant	10 s	←
Operating temperature range at zero power	-25 to +125 °C	
at maximum power	0 to +55 °C	

APPLICATION

Temperature sensing and control. ←

DESCRIPTION

The thermistor has a negative temperature coefficient. It consists of a disc with two tinned copper wires. It is grey lacquered and colour coded, but not insulated.

MECHANICAL DATA

Outlines

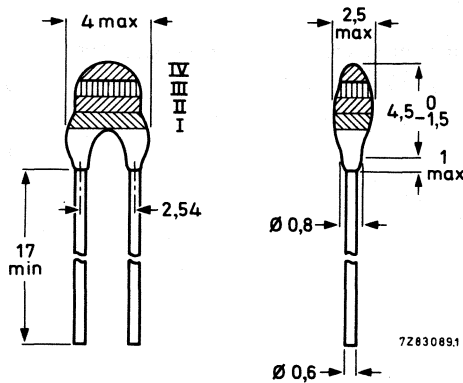

Fig. 1.

Marking

The thermistors are marked with colour bands in accordance with Fig. 1 and Table 1.

Mass

0,14 g approximately.

Mounting

In any position by soldering

Robustness of terminations

Tensile strength 10 N

Bending 5 N

Soldering

Solderability max. 240 °C, max. 4 s

Resistance to heat max. 265 °C, max. 11 s

Impact

Free fall 1 m

Uninflamable

Resistant to solvents

According to IEC 68-2-45, resistant to R113 at T_{amb}

PACKAGING

500 thermistors in a cardboard box.

ELECTRICAL DATA

Unless otherwise specified, measured according to IEC publication 539.

Maximum dissipation at T_{amb} = +55 °C *

0,25 W

→ Dissipation factor*

7,0 mW/K approx.

→ Thermal time constant *

10 s approx.

Heat capacity*

0,135 J/K approx.

Operating temperature range

at zero power

-25 to +125 °C

at maximum power

0 to + 55 °C

* Measured in the measuring set described in the French norm NF C93-271, and clamped at 10 mm from the body.

Table 1

catalogue number 2322 640 1....		R ₂₅	B _{25/85} ± 5%	B _{-25/25} ± 5%	temperature coefficient at +25 °C %/K	colour code *		
R ₂₅ ± 5%	R ₂₅ ± 10%	Ω	K	K		I	II	III
3272	2272	2 700	4000	3800	-4,50	red	violet	red
3472	2472	4 700	3660	3440	-4,12	yellow	violet	red
3123	2123	12 000	3700	3540	-4,17	brown	red	orange
3223	2223	22 000	3700	3420	-4,17	red	red	orange
3473	2473	47 000	3850	3570	-4,33	yellow	violet	orange
3683	2683	68 000	3880	3590	-4,37	blue	grey	orange
3334	2334	330 000	4150	3830	-4,67	orange	orange	yellow

* Thermistors with a 50% tolerance have a gold band IV; 10% tolerance is identified by a silver band IV (Fig. 1). If band IV is not used see 2322 640 19....

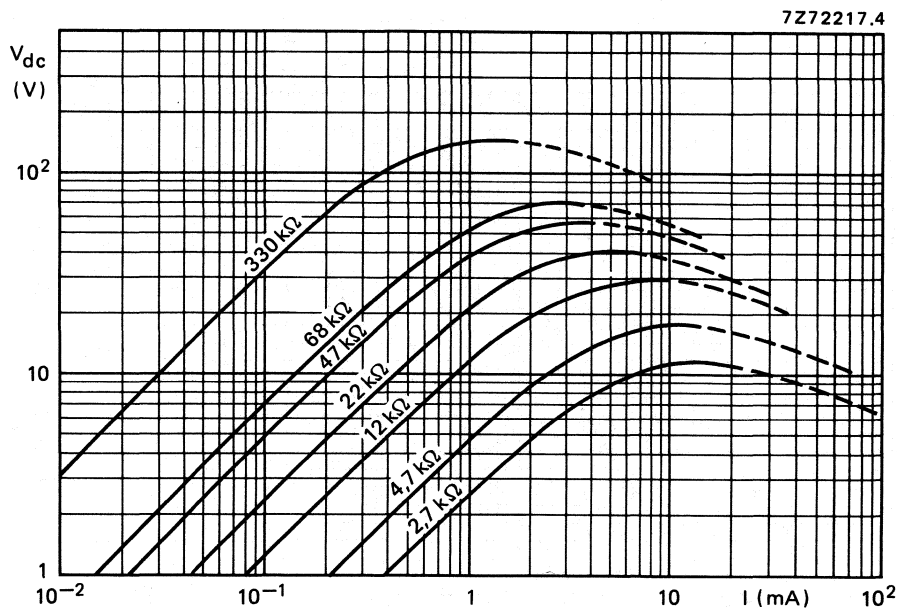

Fig. 2 Typical voltage/current characteristics. T_{amb} = +25 °C, still air.

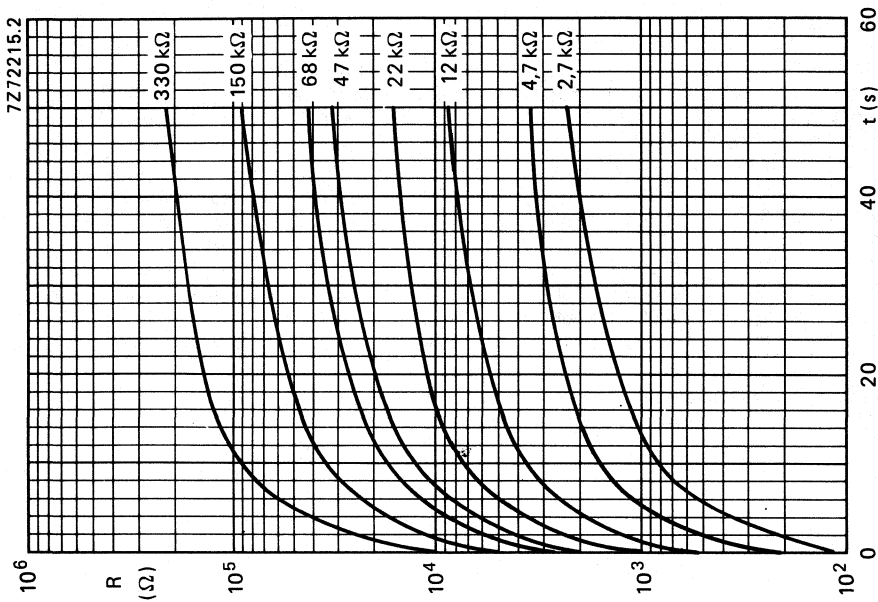

Fig. 4 Typical resistance/time (cooling) characteristic.
T_{amb} = + 25 °C, still air; T_{start} = + 125 °C.

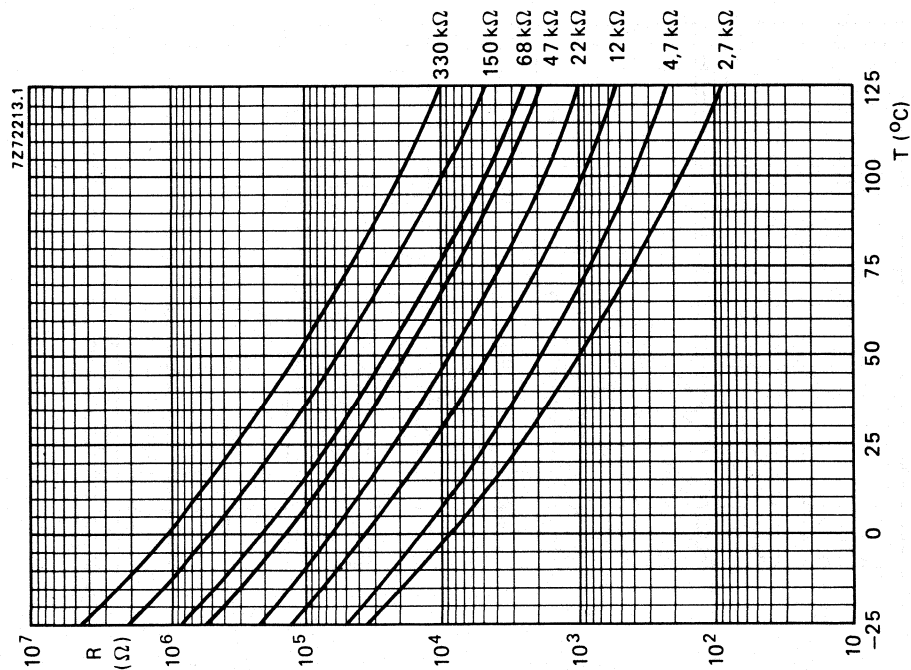

Fig. 3 Typical resistance/temperature characteristic.

NTC THERMISTORS

two-point sensors

APPLICATION

For accurate temperature measurement between 0 and 30 °C e.g. panel heating. ←

DESCRIPTION

The thermistor has a negative temperature coefficient. It consists of a disc with two tinned copper wires. It is grey lacquered and colour coded, but not insulated.

MECHANICAL DATA

Outlines

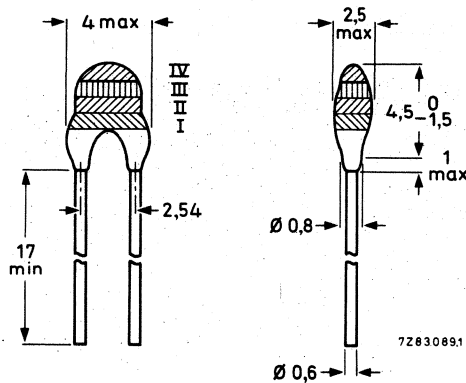

Fig. 1.

Marking

The thermistors are marked with colour bands, see table for colour code.

Mass

0,14 g approximately

Resistant to cleaning solvents

ELECTRICAL DATA

Unless otherwise specified, measured according to IEC publication 539.

Maximum dissipation at $T_{amb} = + 55 \text{ °C}^*$

0,25 W

Dissipation factor*

7,0 mW/K approx. ←

Thermal time constant*

10 s approx. ←

Heat capacity*

0,135 J/K approx.

Operating temperature range

at zero power

-25 to + 125 °C

at maximum power

0 to + 55 °C

* Measured in the measuring set described in the French standard NF C93-271, and clamped at 10 mm from the body.

catalogue number	nominal resistance value Ω		colour code*		
	$5 \pm 1 \text{ }^\circ\text{C}$	$25 \pm 1 \text{ }^\circ\text{C}$	I	II	III
2322 640 19 ...					
472	10 900	4 700	yellow	violet	red
103	23 000	10 000	brown	black	orange
223	52 000	22 000	red	red	orange
473	114 000	47 000	yellow	violet	orange
104	250 000	100 000	brown	black	yellow

* Band IV is not used.

The nominal resistance value should be reached between 4 and 6 $^\circ\text{C}$ and also between 24 and 26 $^\circ\text{C}$.

PACKAGING

500 thermistors in a cardboard box.

NTC THERMISTORS

moulded

QUICK REFERENCE DATA

	2322 640 90004	2322 640 98004
Resistance value at		
+25 °C	12 ± 7%	12 ± 7% kΩ
+100 °C	950 ± 5%	950 ± 5% Ω
B _{25/85} -value	3750	3750 K
Maximum dissipation	0,25	0,25 W
Dissipation factor	7	9,5 mW/K
when mounted on a heat-sink	19	27 mW/K
Thermal time constant	19	33 s
when mounted on a heat-sink	10	5 s
Operating temperature range		
at zero power	-10 to +125	-10 to +125 °C
at maximum power	0 to +55	0 to +55 °C

APPLICATION

For temperature control.

DESCRIPTION

Moulded disc thermistor with negative temperature coefficient and with two solid tinned copper wires. The body colour is dark grey.

The thermistor 2322 640 98004 is provided with a metal strip for mounting.

MECHANICAL DATA

Outlines

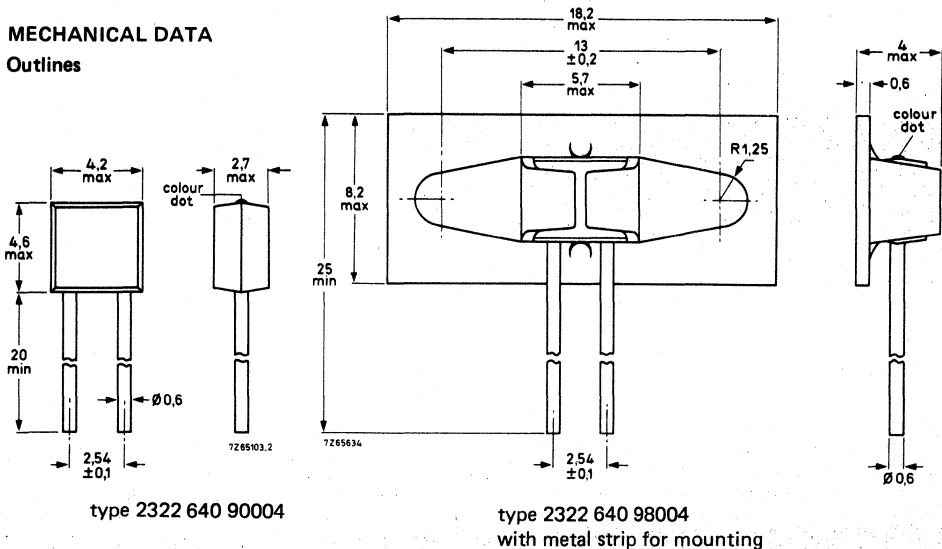

Marking

The thermistors have a grey dot.

Mass

Type 2322 640 90004

0,3 g approx.

Type 2322 640 98004

0,5 g approx.

Mounting

Type 2322 640 90004

in any position by soldering

Type 2322 640 98004

by means of the mounting strip

Robustness of terminations

Tensile strength

10 N

Bending

5 N

Soldering

Solderability

max. 240 °C, max. 4 s

Resistance to heat

max. 265 °C, max. 11 s

Impact

Free fall

1 m

Inflammability

Uninflammable – CCTU-01-01A specification, test 22.

PACKAGING

Type 2322 640 90004: 500 thermistors in a cardboard box.

Type 2322 640 98004: 400 thermistors in a cardboard box.

ELECTRICAL DATA

Unless otherwise specified, measured according to IEC publication 539.

All values in the table without further indication are approximate values.

	2322 640 90004	2322 640 98004	
Resistance at			
+ 25 °C	12 ± 7%	12 ± 7%	kΩ
+ 100 °C	950 ± 5%	950 ± 5%	Ω
B _{25/85} -value	3750	3750	K
Temperature coefficient	-4,2	-4,2	%/K
Maximum dissipation	0,25	0,25	W
Dissipation factor	7	9,5	mW/K
when mounted on a heatsink *	19	27	mW/K
Thermal time constant	19	33	s
when mounted on a heatsink *	10	5	s
Heat capacity of ceramic	0,028	0,028	J/K
of complete component	0,13	0,3	J/K
Response time**	3	3	s
Operating temperature range			
at zero power	-10 to +125	-10 to +125	°C
at maximum power	0 to +55	0 to +55	°C
Dielectric withstanding voltage (r.m.s.)			
between terminals and coating/strip	min. 350	min. 350	V
Insulation resistance between terminals			
and coating/strip at 100 V (d.c.)	min. 100	min. 100	MΩ

* Measurements made in still air with the thermistor mounted on a heatsink of 100 cm², thickness 1,5 mm, and connected between phosphor-bronze wires (φ1,3 mm).

** The thermistor being transferred from ambient air of + 25 °C to a silicone oil (MS200/50) bath of + 85 °C.

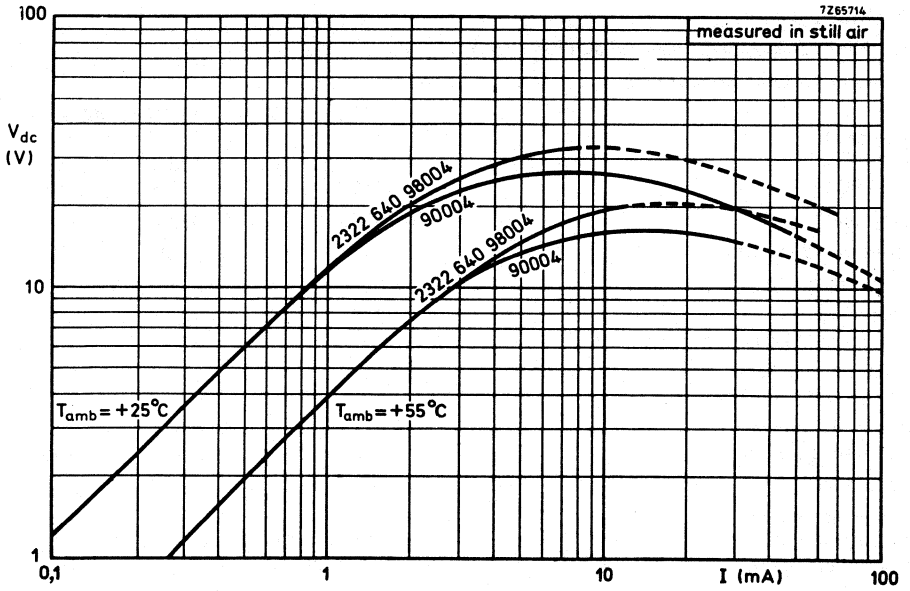

Fig. 2 Typical voltage/current characteristics.

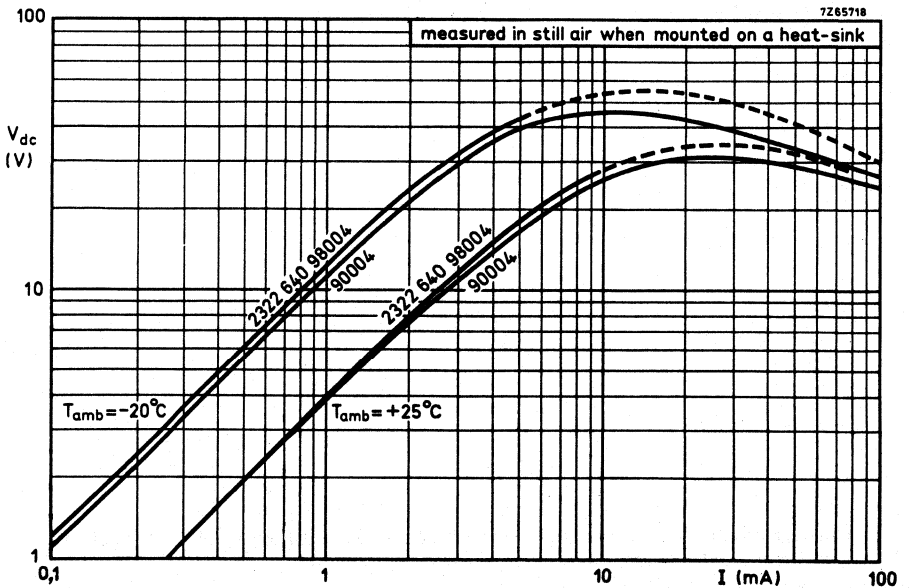

Fig. 3 Typical voltage/current characteristics.

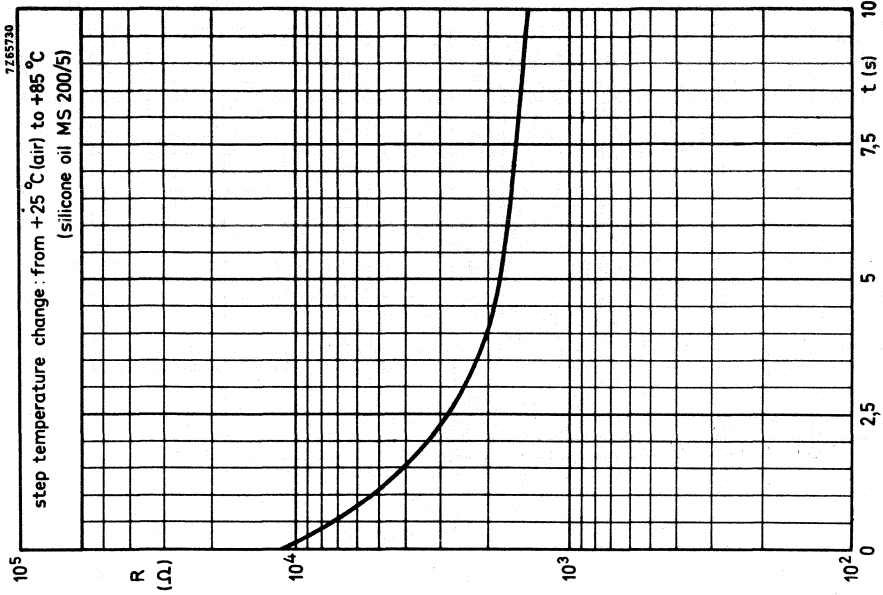

Fig. 5 Typical resistance/response time characteristics.

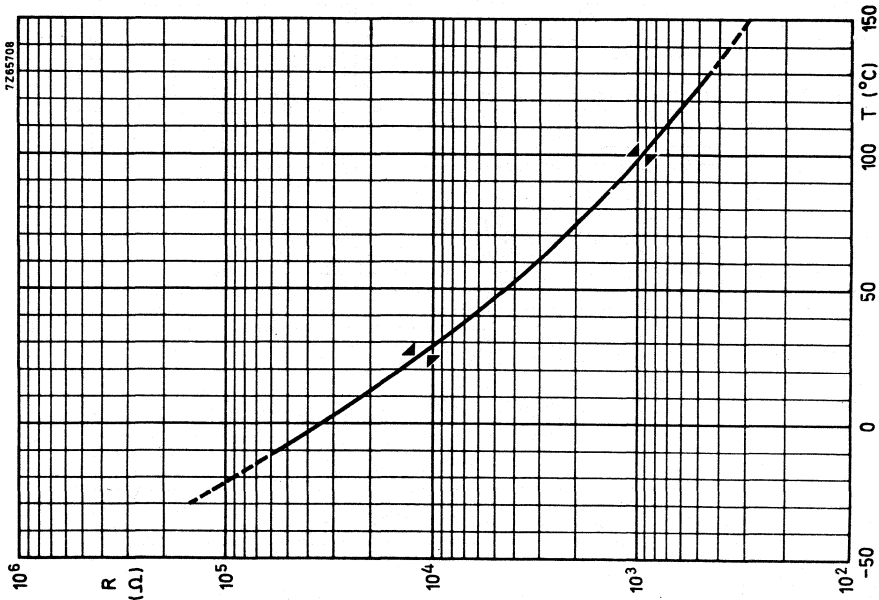

Fig. 4 Typical resistance/temperature characteristics.

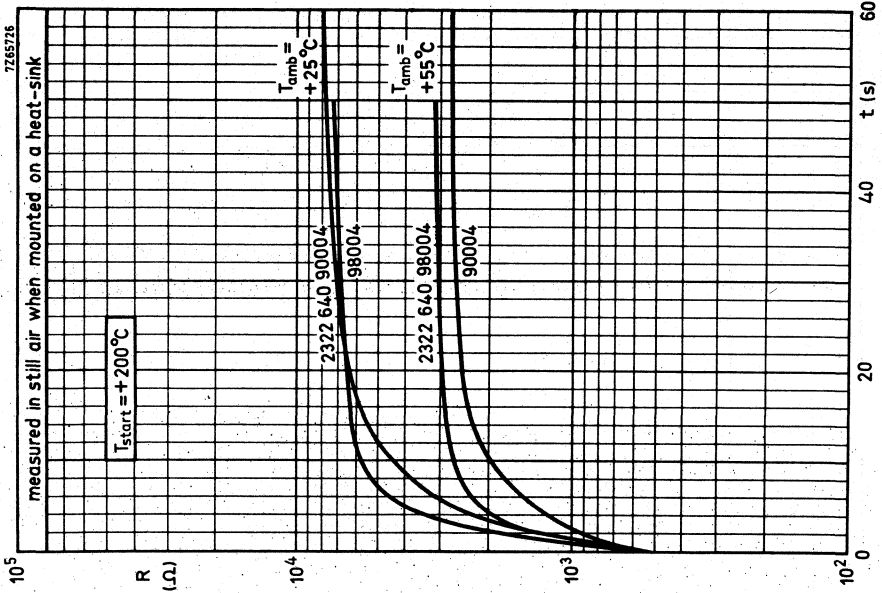

Fig. 7 Typical resistance/time (cooling) characteristics.

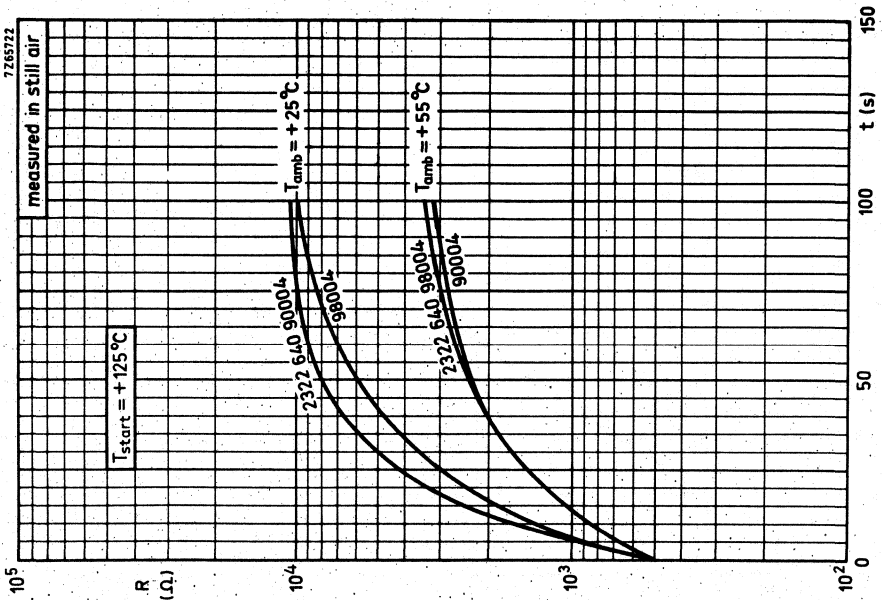

Fig. 6 Typical resistance/time (cooling) characteristics.

NTC THERMISTORS

moulded

QUICK REFERENCE DATA

	2322 640 90005	2322 640 98005	
Resistance at			
+ 100 °C	16,7 ± 7%	16,7 ± 7%	kΩ
+ 200 °C	1120 ± 7%	1120 ± 7%	Ω
B _{25/85} -value	4300	4300	K
Maximum dissipation	0,25	0,25	W
Dissipation factor	7	9,5	mW/K
when mounted on a heat-sink	17,5	20,5	mW/K
Thermal time constant	19	33	s
when mounted on a heat-sink	12	8,5	s
Operating temperature range			
at zero power	-25 to +200	-25 to +200 °C	
at maximum power	0 to +55	0 to +55 °C	

APPLICATION

For high temperature control.

DESCRIPTION

Moulded disc thermistor with negative temperature control and with two solid tinned copper wires. The body colour is dark grey. The thermistor 2322 640 98005 is provided with a metal strip for mounting.

MECHANICAL DATA

Outlines

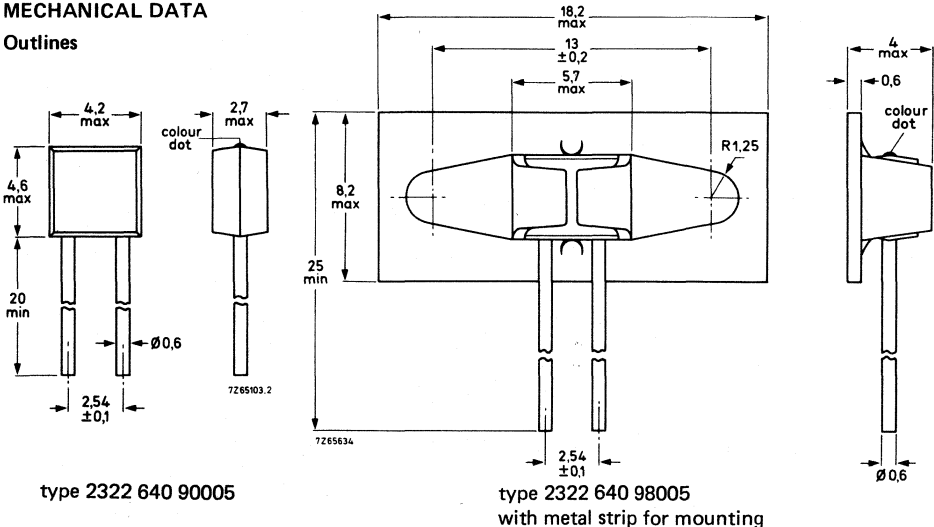

Marking

The thermistors have a blue dot.

Mass

Type 2322 640 90005

0,3 g approx.

Type 2322 640 98005

0,5 g approx.

Mounting

Type 2322 640 90005

in any position by soldering

Type 2322 640 98005

by means of the mounting strip

Robustness of terminations

Tensile strength

10 N

Bending

5 N

Soldering

Solderability

max. 240 °C, max. 4 s

Resistance to heat

max. 265 °C, max. 11 s

Impact

Free fall

1 m

Inflammability

Uninflammable – CCTU-01-01A specification, test 22.

PACKAGING

Type 2322 640 90005: 500 thermistors in a cardboard box.

Type 2322 640 98005: 400 thermistors in a cardboard box.

ELECTRICAL DATA

Unless otherwise specified, measuring according to IEC publication 539.

All values in the table without further indication are approximate values.

	2322 640 90005	2322 640 98005	
Resistance at			
+ 100 °C	16,7 ± 7%	16,7 ± 7%	kΩ
+ 200 °C	1120 ± 7%	1120 ± 7%	Ω
+ 25 °C	310	310	kΩ
B _{25/85} -value	4300	4300	K
Temperature coefficient	-4,85	-4,85	%/K
Maximum dissipation	0,25	0,25	W
Dissipation factor	7	9,5	mW/K
when mounted on a heatsink *	17,5	20,5	mW/K
Thermal time constant	19	33	s
when mounted on a heatsink *	12	8,5	s
Heat capacity of ceramic	0,028	0,028	J/K
of complete component	0,13	0,31	J/K
Response time **	3	3	s
Operating temperature range			
at zero power	-25 to +200	-25 to +200	°C
at maximum power	0 to +55	0 to +55	°C
Dielectric withstanding voltage (r.m.s.)			
between terminals and coating	min. 350	min. 350	V
Insulation resistance between terminals			
and coating at 100 V (d.c.)	min. 100	min. 100	MΩ

* Measurements made in still air with the thermistor mounted on a heatsink of 100 cm², thickness 1,5 mm, connected between phosphor-bronze wires (φ 1,3 mm).

** The thermistor being transferred from ambient air of + 25 °C to a silicone oil (MS200/50) bath of + 85 °C.

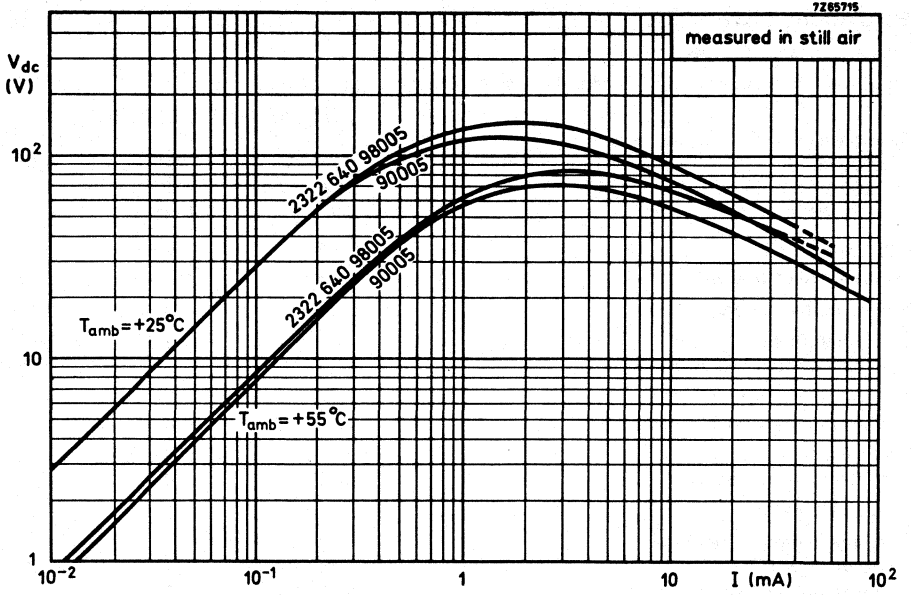

Fig. 2 Typical voltage/current characteristics.

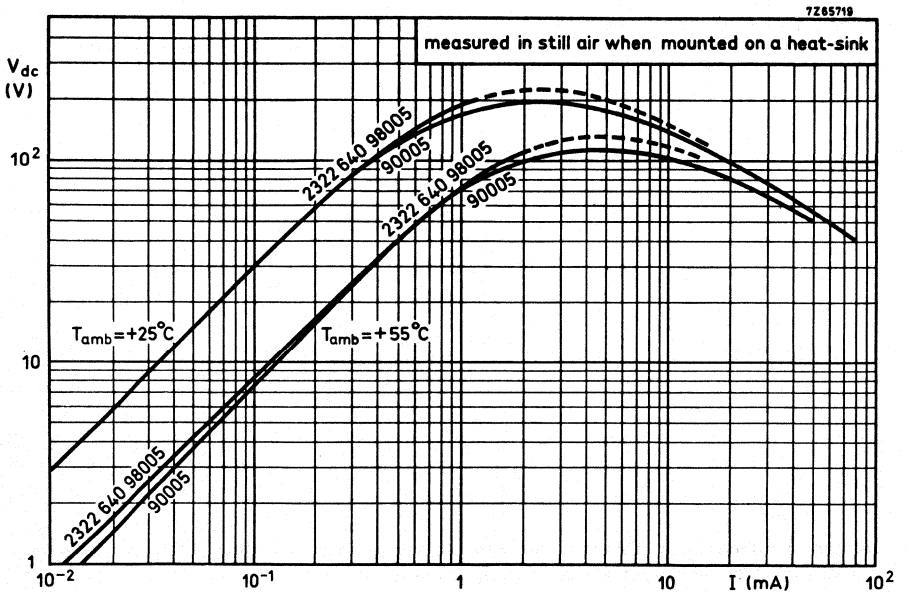

Fig. 3 Typical voltage/current characteristics.

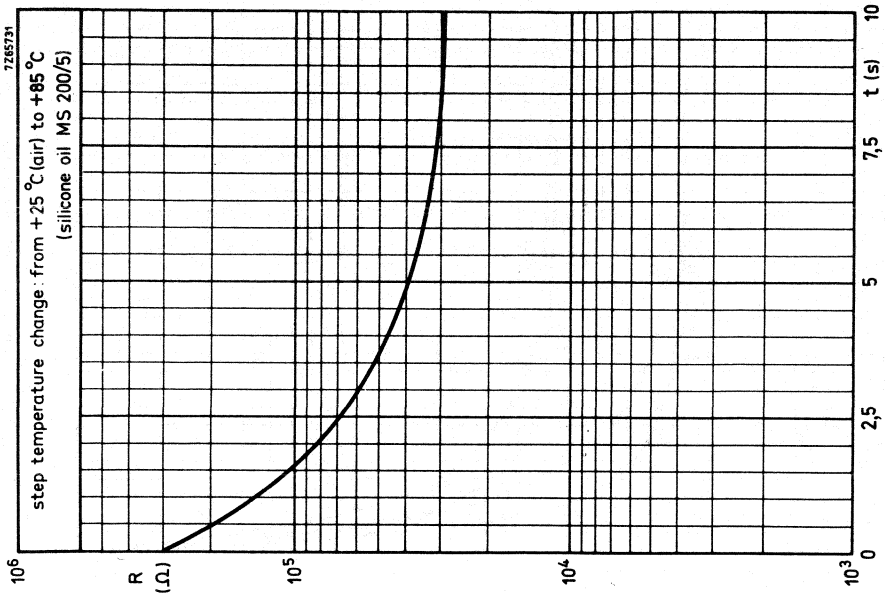

Fig. 5 Typical resistance/response time characteristics.

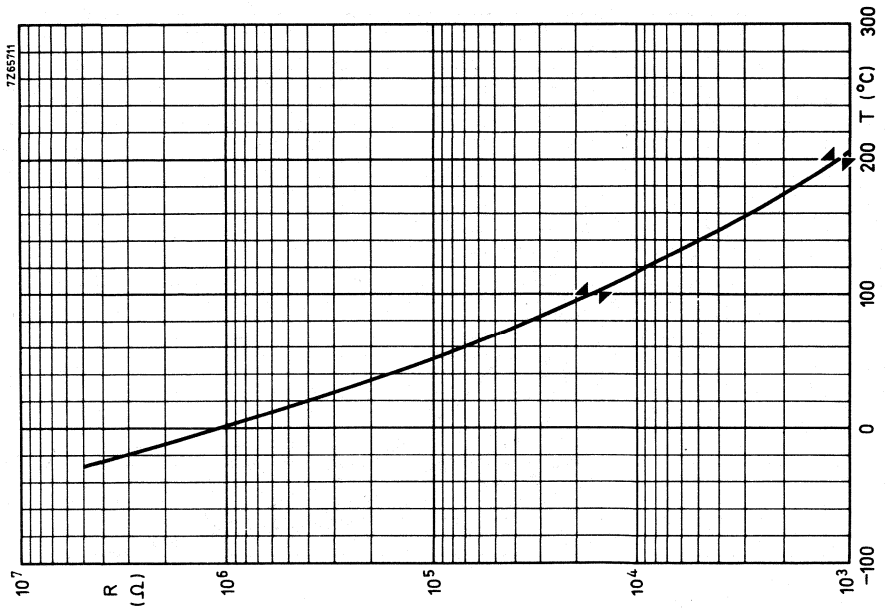

Fig. 4 Typical resistance/temperature characteristics.

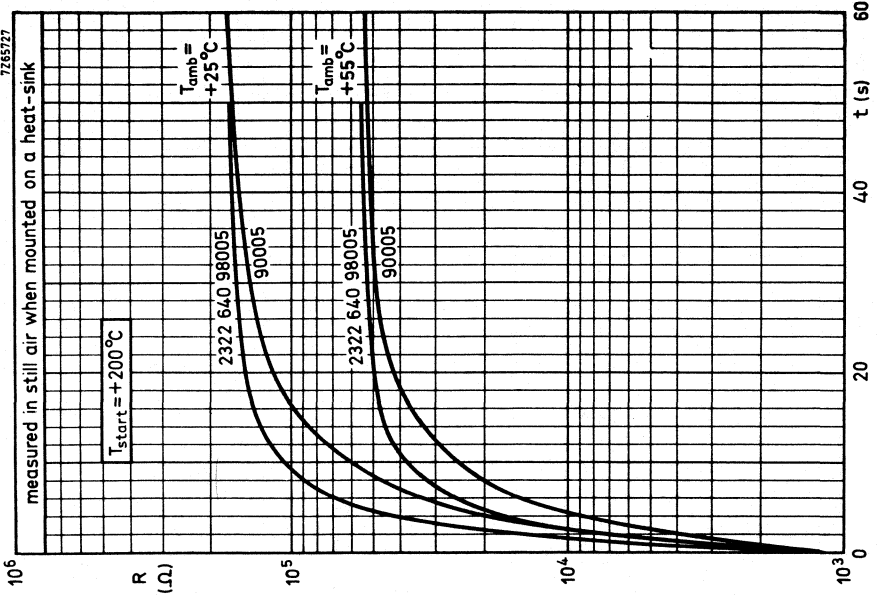

Fig. 7 Typical resistance/time (cooling) characteristics.

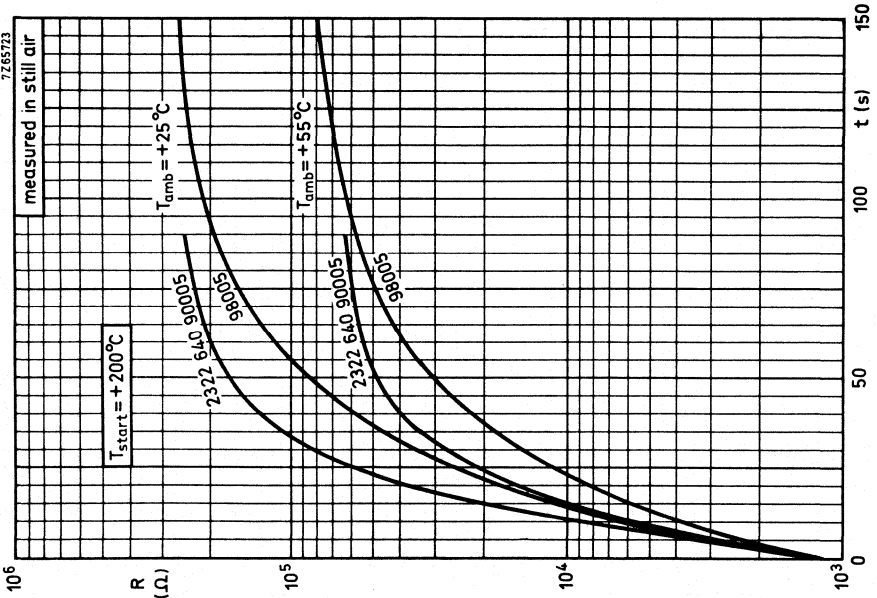

Fig. 6 Typical resistance/time (cooling) characteristics.

NTC THERMISTORS

QUICK REFERENCE DATA

	2322 640 90007	2322 640 90021
Resistance value		
at +25 °C	12 kΩ ± 7%	12 kΩ ± 5,5%
at +90 °C	1,3 kΩ ± 5%	1285 Ω ± 3,5%
B _{25/85} -value	3700 K	3720 K
Maximum dissipation	0,25 W	
Dissipation factor		
in still air	7,5 mW/K	
in still water	18 mW/K	
Thermal time constant in still air	285 s	
Operating temperature range		
at zero power, continuously	-25 to +110 °C	
for max. 24 h	to +130 °C	
at maximum power	0 to +55 °C	

APPLICATION

As a temperature sensor for water temperature control in washing machines, dish washers, electric boilers, etc.

DESCRIPTION

Disc thermistor with negative temperature coefficient, mounted in a capsule of stainless steel, with two tinned brass spade connectors.

MECHANICAL DATA

Outlines

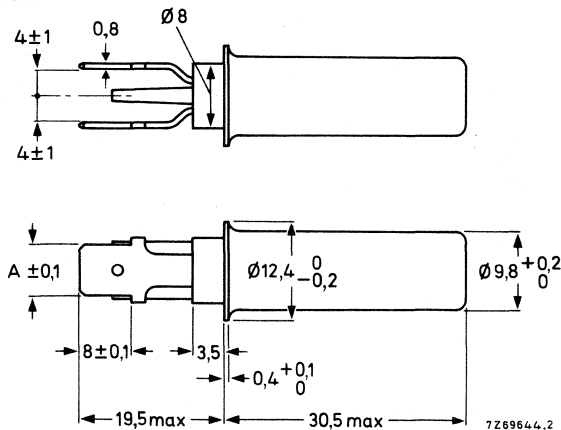

Fig. 1.

A = 6,3 mm for thermistor 2322 640 90007
A = 2,8 mm for thermistor 2322 640 90021

Marking

2322 640 90007
2322 640 90021

brown dot between connectors
orange dot between connectors

Mass

8 g approximately

Mounting

In any position

Robustness of terminations

Tensile strength

50 N

Impact

Free fall

1 m

Inflammability

Uninflammable

ELECTRICAL DATA

Unless otherwise specified, measuring according to IEC publication 539.

Type	2322 640 90007	2322 640 90021
Resistance at +25 °C	12 kΩ ± 7%	12 kΩ ± 5,5%
+90 °C	1,3 kΩ ± 5%	1285 Ω ± 3,5%
B _{25/85} -value	3700 K	3720 K
Temperature coefficient	-4,2%/K	
Maximum dissipation	0,25 W	
Dissipation factor in still air	7,5 mW/K	
in still water	18 mW/K	
Thermal time constant in still air	285 s	
Response time*	11 s	
Temperature gradient**	0,02 K/K	
Operating temperature range at zero power	min. -25 °C	
continuously	max. +110 °C	
max. 24 h	max. +130 °C	
at maximum power	0 to +55 °C	
Dielectric withstanding voltage (r.m.s.) between terminals and capsule for 10 s	min. 1650 V	
60 s	min. 1500 V	
Insulation resistance between terminals and capsule at 100 V (d.c.)	min. 100 MΩ	

PACKAGING

50 thermistors in a cardboard in box.

* The thermistor being transferred from ambient air of +25 °C to water of +100 °C.

** The temperature gradient is the difference between the liquid (water) temperature and the temperature measured by the sensor per degree difference between liquid and connector temperatures. This difference is caused by the heat conduction through the connectors.

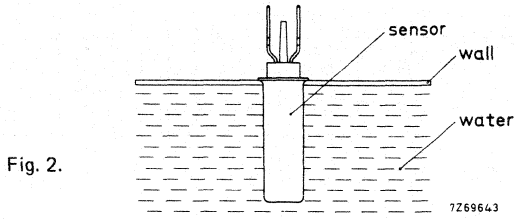

Fig. 2.

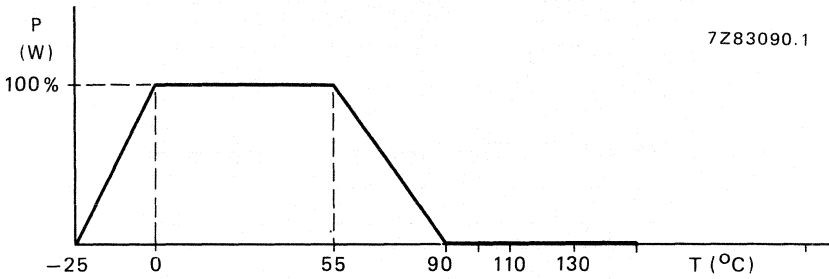

Fig. 3 Power derating with ambient temperature.

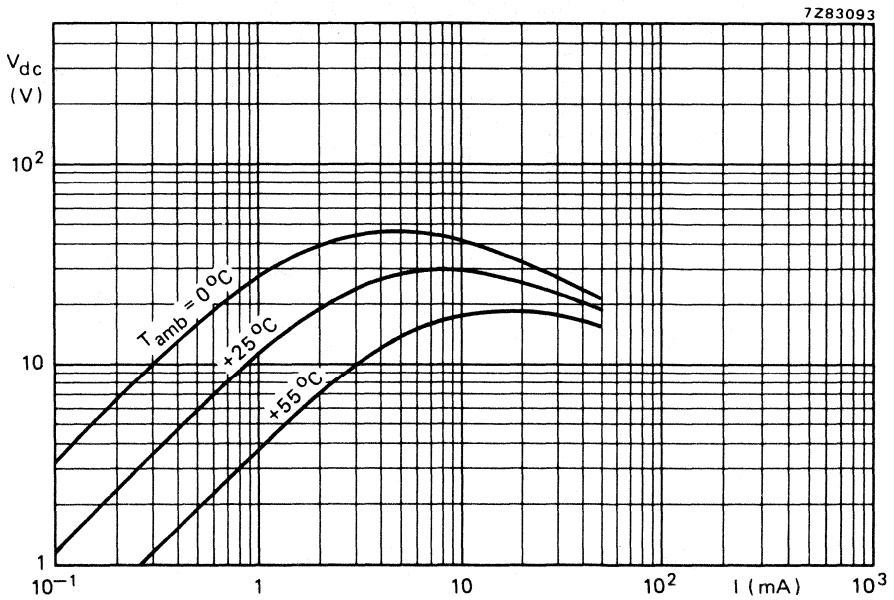

Fig. 4 Typical voltage/current characteristic measured in still air.

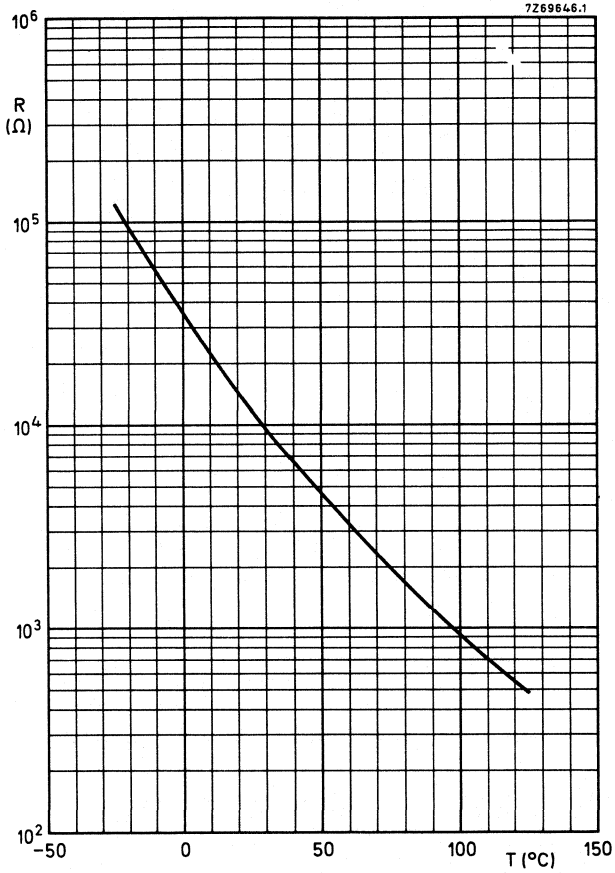

Fig. 5 Typical resistance/temperature characteristic.

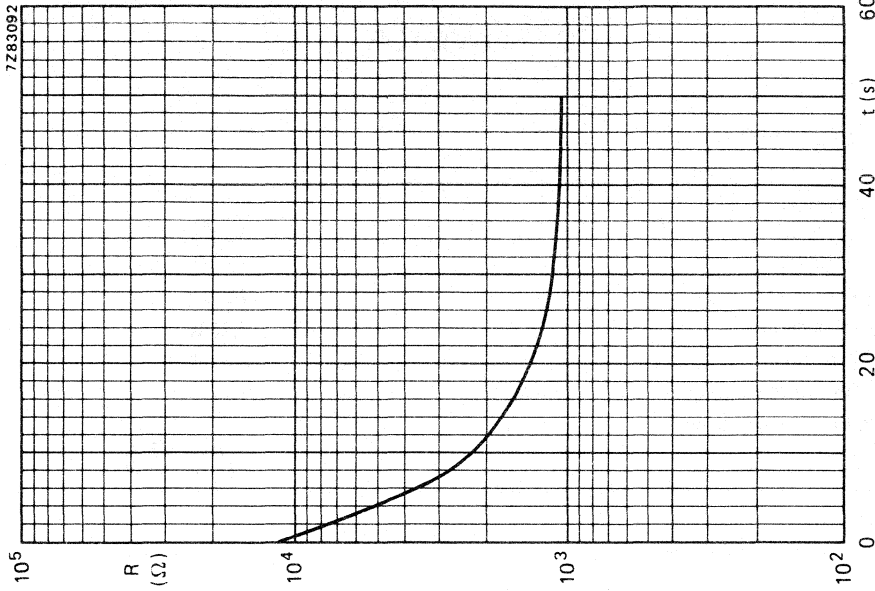

Fig. 7 Typical resistance/response time characteristic. Temperature step from still air of +25 °C to still water of +100 °C.

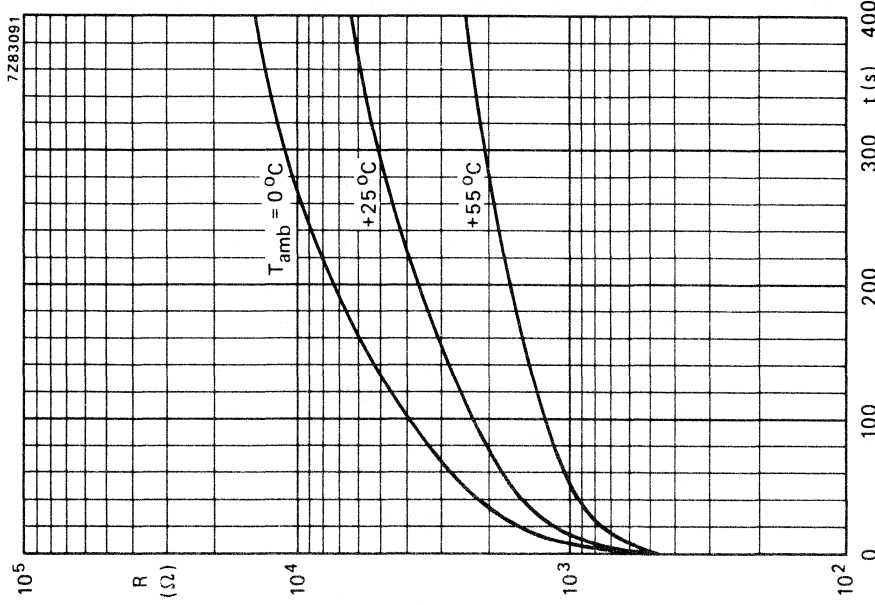

Fig. 6 Typical resistance/time (cooling) characteristics measured in still air, T_{start} = +125 °C.

NTC THERMISTOR

QUICK REFERENCE DATA

Resistance value	
at $-30 \pm 1,5 \text{ }^\circ\text{C}$	50 k Ω
at $-20 \pm 1,5 \text{ }^\circ\text{C}$	27 k Ω
at $-10 \pm 1,5 \text{ }^\circ\text{C}$	15 k Ω
B _{25/85} -value	4000 K
Maximum dissipation	0,25 W
Dissipation factor	7,5 mW/K
Thermal time constant	19 s
Operating temperature range	
at zero power	$-55 \text{ to } +85 \text{ }^\circ\text{C}$
at maximum power	$-55 \text{ to } +55 \text{ }^\circ\text{C}$

APPLICATION

For temperature control in deep-freezers.

DESCRIPTION

The thermistor has a negative temperature coefficient. It consists of a disc with two solid tinned copper wires. It is grey lacquered and colour coded, but not insulated.

MECHANICAL DATA

Outlines

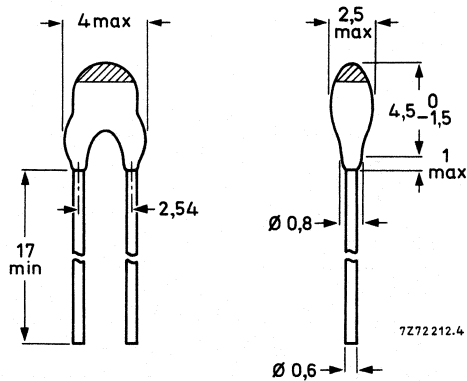

Fig.1.

Marking

The thermistor is marked with a brown band on top of the body.

Mass

0,14 g approximately.

Mounting

In any position by soldering.

Robustness of terminations

Tensile strength	10 N
Bending	5 N

Soldering

Solderability	max. 240 °C, max. 4 s
Resistance to heat	max. 265 °C, max. 11 s

Impact

Free fall	1 m
-----------	-----

Uninflamable**Resistant to cleaning solvents****PACKAGING**

500 thermistors in a cardboard box.

ELECTRICAL DATA

Unless otherwise specified, measured according to IEC publication 539.

Resistance value

at $-30 \pm 1,5$ °C	50 k Ω
at $-20 \pm 1,5$ °C	27 k Ω
at $-10 \pm 1,5$ °C	15 k Ω

B_{25/85}-value

4000 K approx.

Temperature coefficient at +25 °C

-4,5 %/K approx.

Maximum dissipation at T_{amb} = +55 °C

0,25 W

Dissipation factor

7,5 mW/K approx.

Thermal time constant

19 s approx.

Heat capacity

0,135 J/K approx.

Operating temperature range

at zero power	-55 to +85 °C
at maximum power	-55 to +55 °C

NTC THERMISTORS

moulded

QUICK REFERENCE DATA

	2322 640 90013	2322 640 98013	
Resistance value			
at $-30 \pm 1,5 \text{ }^\circ\text{C}$	50	50	k Ω
at $-20 \pm 1,5 \text{ }^\circ\text{C}$	27	27	k Ω
at $-10 \pm 1,5 \text{ }^\circ\text{C}$	15	15	k Ω
B _{25/85} -value	4000	4000	K
Maximum dissipation	0,25	0,25	W
Dissipation factor	6,7	9	mW/K
when mounted on a heatsink	16	21	mW/K
Thermal time constant	17	32	s
when mounted on a heatsink	6	3	s
Operating temperature range			
at zero power	-55 to $+85$	-55 to $+85$	$^\circ\text{C}$
at maximum power	-55 to $+55$	-55 to $+55$	$^\circ\text{C}$

APPLICATION

For temperature control in deep-freezers.

DESCRIPTION

Dark grey moulded disc thermistor with negative temperature coefficient and with two solid tinned copper wires. The thermistor 2322 640 98013 has a metal strip for mounting.

MECHANICAL DATA

Outlines

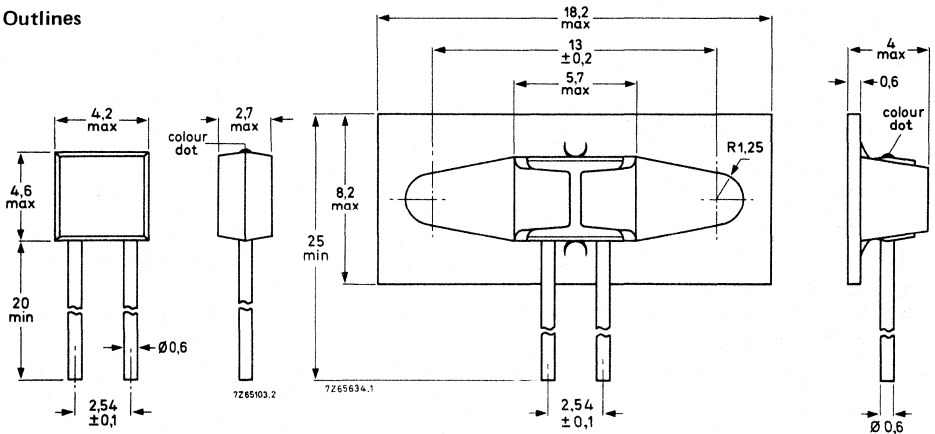

Fig.1 Type 2322 640 90013.

Fig.2 Type 2322 640 98013 with metal strip for mounting.

Marking

The thermistors have a brown dot.

Mass

Type 2322 640 90013	0,3 g approx.
Type 2322 640 98013	0,5 g approx.

Mounting

Type 2322 640 90013	in any position by soldering
Type 2322 640 98013	by means of the mounting strip

Robustness of terminations

Tensile strength	10 N
Bending	5 N

Soldering

Solderability	max. 240 °C, max. 4 s
Resistance to heat	max. 265 °C, max. 11 s, solder bath 5 mm from body

Impact

Free fall	1 m
-----------	-----

Inflammability

Uninflammable

PACKAGING

Type 2322 640 90013: 500 thermistors in a cardboard box.
Type 2322 640 98013: 400 thermistors in a cardboard box.

ELECTRICAL DATA

Unless otherwise specified, measured according to IEC publication 539.

All values in the table without further indication are approximate values.

	2322 640 90013	2322 640 98013	
Resistance value			
at $-30 \pm 1,5$ °C	50	50	k Ω
at $-20 \pm 1,5$ °C	27	27	k Ω
at $-10 \pm 1,5$ °C	15	15	k Ω
B25/85-value	4000	4000	K
Temperature coefficient	-4,5	-4,5	%/K
Maximum dissipation at $T_{amb} = +55$ °C	0,25	0,25	W
Dissipation factor	6,7	9	mW/K
when mounted on a heatsink *	16	21	mW/K
Thermal time constant	17	32	s
when mounted on a heatsink *	6	3	s
Heat capacity			
of ceramic	0,009	0,009	J/K
of complete component	0,11	0,29	J/K
Response time **	1,3		s
Operating temperature range			
at zero power	-55 to +85	-55 to +85	°C
at maximum power	-55 to +55	-55 to +55	°C
Dielectric withstanding voltage (r.m.s.) between terminals and coating	min. 350	min. 350	V
Insulation resistance between terminals and coating at 100 V (d.c.)	min. 100	min. 100	M Ω

* The thermistor mounted on a heatsink of 100 cm², thickness 1,5 mm.

** From air of +25 °C to silicone oil (MS 200/5) of -20 °C.

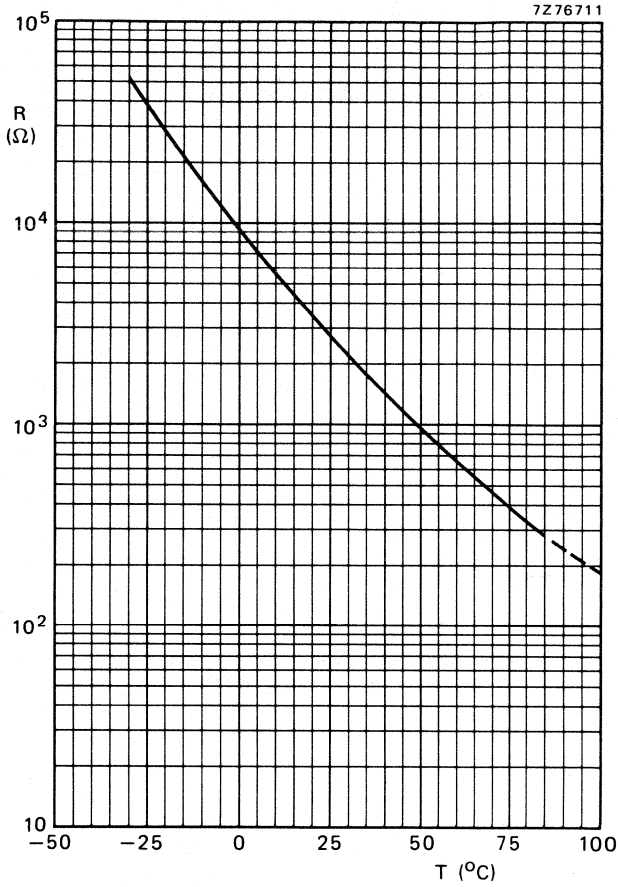

Fig. 3 Typical resistance/temperature characteristic.

NTC THERMISTOR

QUICK REFERENCE DATA

Resistance value	
at $-10 \pm 1,5$ °C	15 k Ω
at $+25 \pm 1,5$ °C	2,7 k Ω
B _{25/85} -value	4000 K
Maximum dissipation	0,25 W
Dissipation factor	7,5 mW/K
Thermal time constant	19 s
Operating temperature range	
at zero power	-55 to +85 °C
at maximum power	-55 to +55 °C

APPLICATION

For room temperature control.

DESCRIPTION

The thermistor has a negative temperature coefficient. It consists of a disc with two solid tinned copper wires. It is grey lacquered and colour coded, but not insulated.

MECHANICAL DATA

Outlines

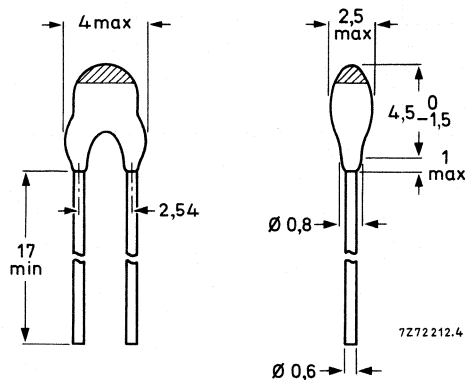

Fig.1.

Marking

The thermistor is marked with a red band on top of the body.

Mass

0,14 g approximately.

Mounting

In any position by soldering.

Robustness of terminations

Tensile strength	10 N
Bending	5 N

Soldering

Solderability	max. 240 °C, max. 4 s
Resistance to heat	max. 265 °C, max. 11 s

Impact

Free fall	1 m
-----------	-----

Uninflammable**Resistant to cleaning solvents****PACKAGING**

500 thermistors in a cardboard box.

ELECTRICAL DATA

Unless otherwise specified, measured according to IEC publication 539.

Resistance value	
at $-10 \pm 1,5$ °C	15 k Ω
at $+25 \pm 1,5$ °C	2,7 k Ω
B25/85-value	\approx 4000 K
Temperature coefficient at +25 °C	\approx -4,5 %/K
Maximum dissipation at $T_{amb} = +55$ °C	0,25 W
Dissipation factor	\approx 7,5 mW/K
Thermal time constant	\approx 19 s approx.
Heat capacity	\approx 0,135 J/K
Operating temperature range	
at zero power	-55 to +85 °C
at maximum power	-55 to +55 °C

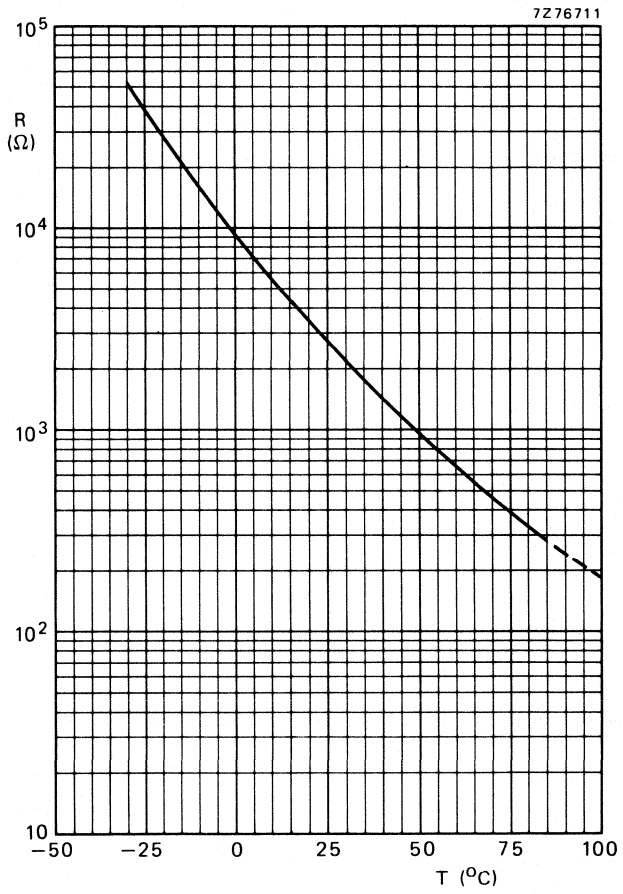

Fig.2 Typical resistance/temperature characteristic.

NTC THERMISTORS

moulded

QUICK REFERENCE DATA

	2322 640 90015	2322 640 98015	
Resistance value			
at $-10 \pm 1,5 \text{ }^\circ\text{C}$	15	15	k Ω
at $+25 \pm 1,5 \text{ }^\circ\text{C}$	2,7	2,7	k Ω
B _{25/85} -value	4000	4000	K
Maximum dissipation	0,25	0,25	W
Dissipation factor	6,7	9	mW/K
when mounted on a heatsink	16	21	mW/K
Thermal time constant	17	32	s
when mounted on a heatsink	6	3	s
Operating temperature range			
at zero power	-55 to $+85$	-55 to $+85$	$^\circ\text{C}$
at maximum power	-55 to $+55$	-55 to $+55$	$^\circ\text{C}$

APPLICATION

For room temperature control.

DESCRIPTION

Moulded disc thermistor with negative temperature coefficient and with two solid tinned copper wires.
Body dark grey.
The thermistor 2322 640 98015 has a metal strip for mounting.

MECHANICAL DATA

Outlines

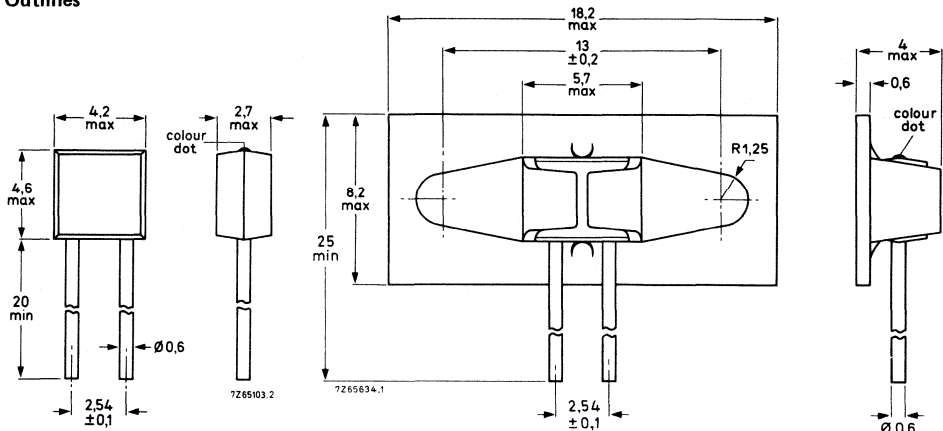

Fig.1 Type 2322 640 90015.

Fig.2 Type 2322 640 98015 with metal strip for mounting.

Marking

The thermistors have a red dot.

Mass

Type 2322 640 90015	0,3 g approx.
Type 2322 640 98015	0,5 g approx.

Mounting

Type 2322 640 90015	in any position by soldering
Type 2322 640 98015	by means of the mounting strip

Robustness of terminations

Tensile strength	10 N
Bending	5 N

Soldering

Solderability	max. 240 °C, max. 4 s
Resistance to heat	max. 265 °C, max. 11 s, solder bath 5 mm from body

Impact

Free fall	1 m
-----------	-----

Inflammability

Uninflammable

PACKAGING

Type 2322 640 90015: 500 thermistors in a cardboard box.
Type 2322 640 98015: 400 thermistors in a cardboard box.

ELECTRICAL DATA

Unless otherwise specified, measured according to IEC publication 539.

All values in the table without further indication are approximate values.

	2322 640 90015	2322 640 98015	
Resistance value			
at $-10 \pm 1,5 \text{ }^\circ\text{C}$	15	15	k Ω
at $+25 \pm 1,5 \text{ }^\circ\text{C}$	2,7	2,7	k Ω
B _{25/85} -value	4000	4000	K
Temperature coefficient	-4,5	-4,5	%/K
Maximum dissipation at T _{amb} = +55 °C	0,25	0,25	W
Dissipation factor	6,7	9	mW/K
when mounted on a heatsink *	16	21	mW/K
Thermal time constant	17	32	s
when mounted on a heatsink *	6	3	s
Heat capacity			J/K
of ceramic	0,009	0,009	J/K
of complete component	0,11	0,29	J/K
Response time **	1,3		s
Operating temperature range			
at zero power	-55 to +85	-55 to +85	°C
at maximum power	-55 to +55	-55 to +55	°C
Dielectric withstanding voltage (r.m.s.) between terminals and coating	min. 350	min. 350	V
Insulation resistance between terminals and coating at 100 V (d.c.)	min. 100	min. 100	M Ω

* The thermistor mounted on a heatsink of 100 cm², thickness 1,5 mm.

** From air of +25 °C to silicone oil (MS 200/5) of -20 °C.

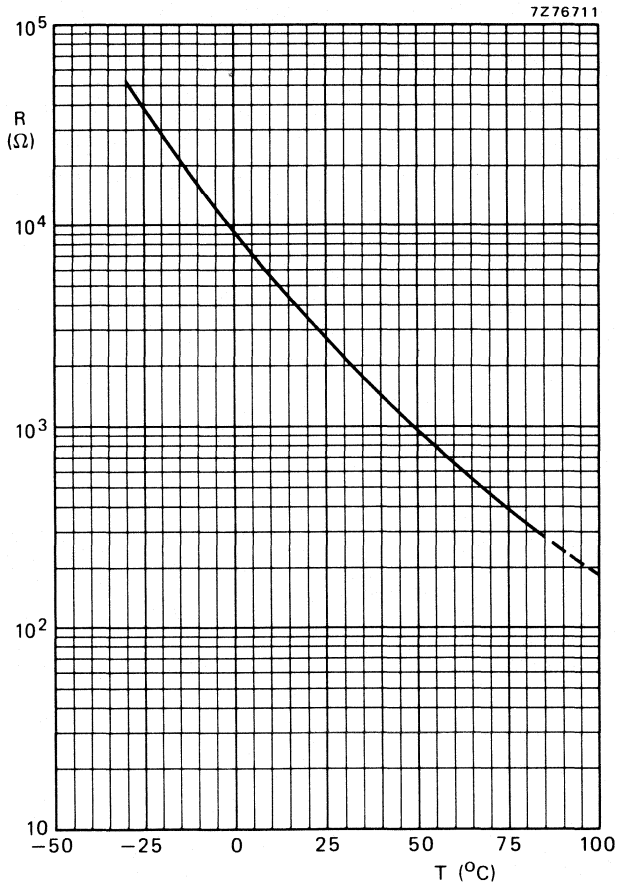

Fig.3 Typical resistance/temperature characteristic.

NTC THERMISTOR

disc

QUICK REFERENCE DATA

Resistance value at + 25 °C	3,3 Ω to 470 kΩ (E6 series)
B _{25/85} value	2675 to 4650 K
Maximum dissipation	0,5 W
Dissipation factor	8,5 mW/K
Thermal time constant	≈ 17 s
Operating temperature range at zero power	-25 to + 125 °C
at maximum power	0 to + 55 °C

APPLICATION

Temperature compensation and temperature sensing.

DESCRIPTION

The thermistor has a negative temperature coefficient, it consists of a disc with two tinned copper wires. It is grey lacquered and colour coded, but not insulated.

MECHANICAL DATA

Outlines

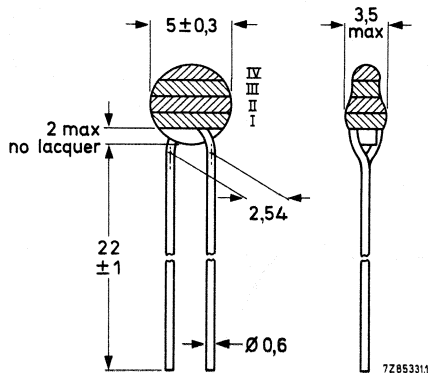

Fig. 1.

PACKAGING

500 thermistors in a cardboard box.

Marking

The thermistors are marked with three or four colour bands in accordance with Fig. 1 and Table 1.

Mass

0,25 g approximately.

Mounting

In any position by soldering.

Robustness of terminations

Tensile strength	10 N
Bending	5 N

Soldering

Solderability	max. 240 °C, max. 4 s
→ Resistance to heat	max. 265 °C, max. 11 s

Impact

Free fall	1 m
-----------	-----

Flammability

Not inflammable according to IEC as described by TC50 (1979), needle flame.

Resistance to solvents

According to IEC 68-2-45, resistant to R113 at T_{amb}.

ELECTRICAL DATA

Unless otherwise specified, measured according to IEC publication 539.

Resistance at 25 °C	see Table 1
B _{25/85} values	see Table 1
Temperature coefficient	see Table 1
Maximum dissipation*	0,5 W
Dissipation factor*	≈ 8,5 mW/K V/K
Thermal time constant*	≈ 17 s
Operating temperature range	
at zero power	-25 to + 125 °C
at maximum power, see Fig. 2	0 to + 55 °C

7282875

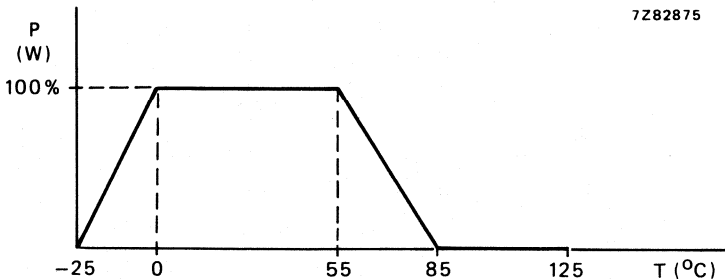

Fig. 2 Derating curve.

* Measured in the measuring set described in the French norm NF C93-271, and clamped at 10 mm from the body.

Table 1 Catalogue number 2322 642 6....

suffix of catalogue number	R25	B _{25/85}	temperature coefficient	colour code (see Marking)			
	Ω	$\pm 5\%$ K	%/K	I	II	III	* IV
.338	3,3	2675	-3,0	orange	orange	gold	
.478	4,7	2750	-3,1	yellow	violet	gold	
.688	6,8	2800	-3,2	blue	grey	gold	
.109	10	2875	-3,2	brown	black	black	
.159	15	2950	-3,3	brown	green	black	
.229	22	3025	-3,4	red	red	black	
.339	33	3100	-3,5	orange	orange	black	
.479	47	3150	-3,5	yellow	violet	black	
.689	68	3225	-3,6	blue	grey	black	
.101	100	3300	-3,7	brown	black	brown	
.151	150	3375	-3,8	brown	green	brown	
.221	220	3475	-3,9	red	red	brown	
.331	330	3575	-4,0	orange	orange	brown	
.471	470	3650	-4,1	yellow	violet	brown	
.681	680	3725	-4,2	blue	grey	brown	
.102	1 000	3825	-4,3	brown	black	red	
.152	1 500	3975	-4,5	brown	green	red	
.222	2 200	4125	-4,6	red	red	red	
.332	3 300	4250	-4,8	orange	orange	red	
.472	4 700	4350	-4,9	yellow	violet	red	
.682	6 800	4400	-5,0	blue	grey	red	
.103	10 000	4275	-4,8	brown	black	orange	
.153	15 000	4200	-4,7	brown	green	orange	
.223	22 000	4275	-4,8	red	red	orange	
.333	33 000	4350	-4,9	orange	orange	orange	
.473	47 000	4400	-5,0	yellow	violet	orange	
.683	68 000	4450	-5,1	blue	grey	orange	
.104	100 000	4500	-5,2	brown	black	yellow	
.154	150 000	4550	-5,2	brown	green	yellow	
.224	220 000	4600	-5,3	red	red	yellow	
.334	330 000	4625	-5,3	orange	orange	yellow	
.474	470 000	4650	-5,4	yellow	violet	yellow	

* Replace dot in catalogue number (9th digit) by:
 2 for a tolerance of 10% on R₂₅, band IV is silver.
 3 for a tolerance of 5% on R₂₅, band IV is gold.

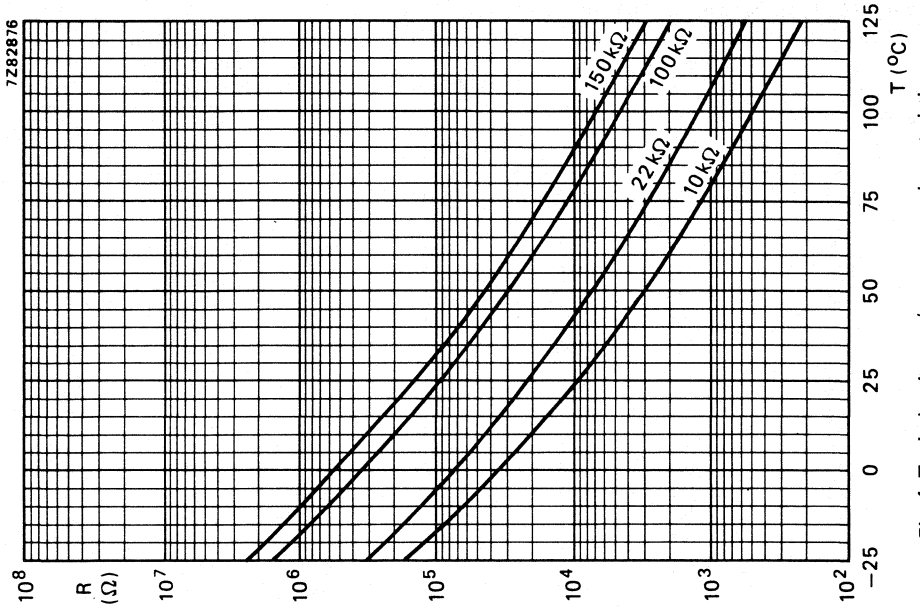

Fig. 4 Typical resistance/temperature characteristic.

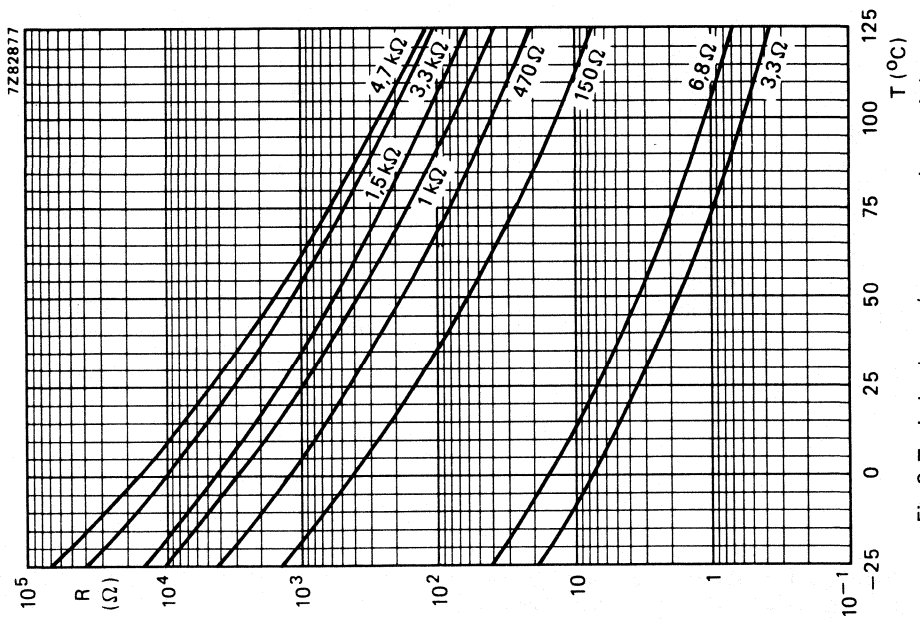

Fig. 3 Typical resistance/temperature characteristic.

7282872

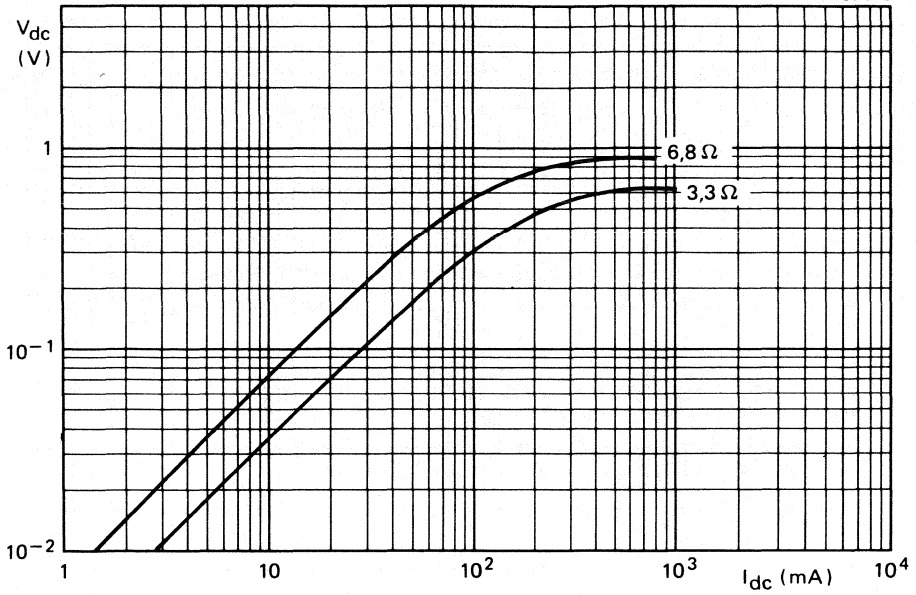

Fig. 5 Typical voltage/current characteristic, $T_{amb} = +25\text{ }^{\circ}\text{C}$, still air.

7282874

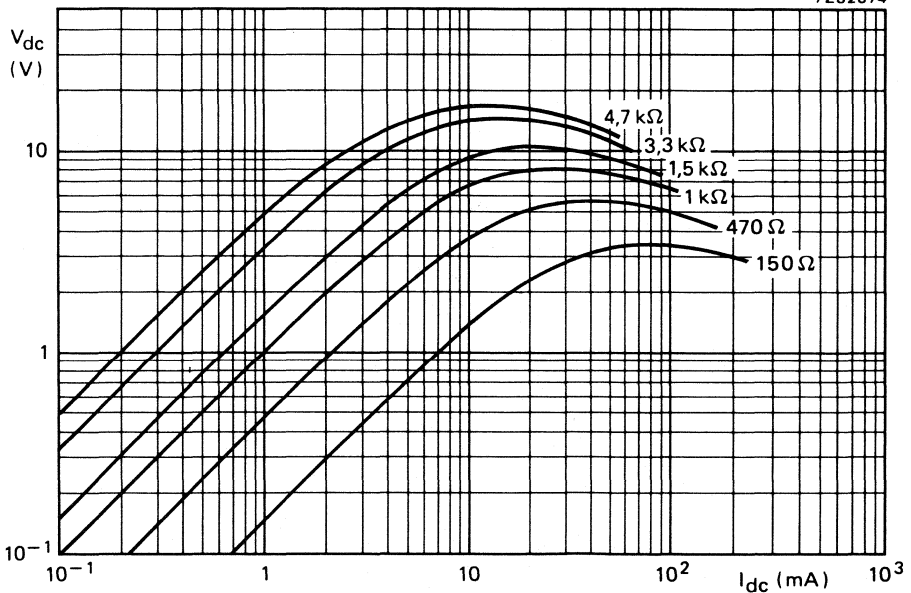

Fig. 6 Typical voltage/current characteristic, $T_{amb} = +25\text{ }^{\circ}\text{C}$, still air.

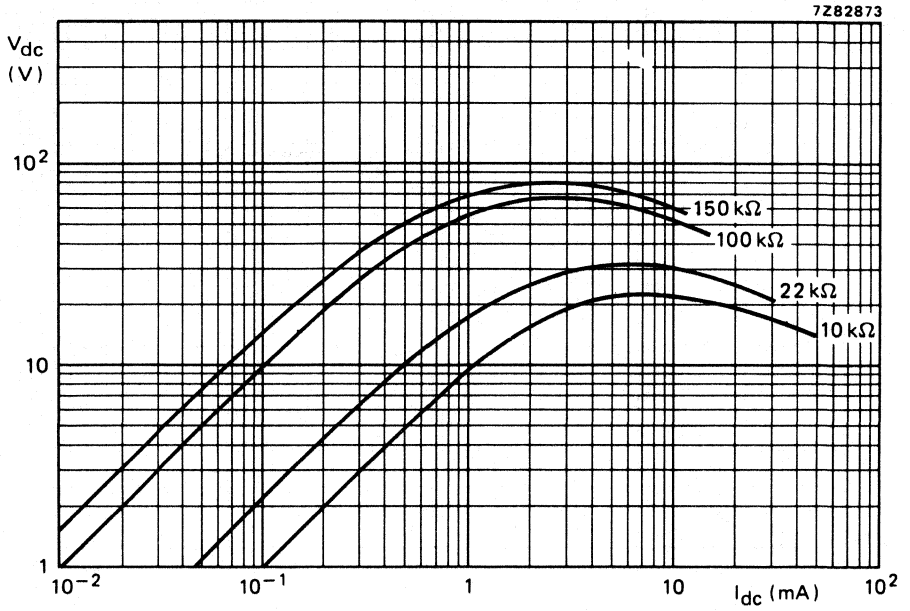

Fig. 7 Typical voltage/current characteristic, $T_{amb} = + 25 \text{ }^\circ\text{C}$, still air.

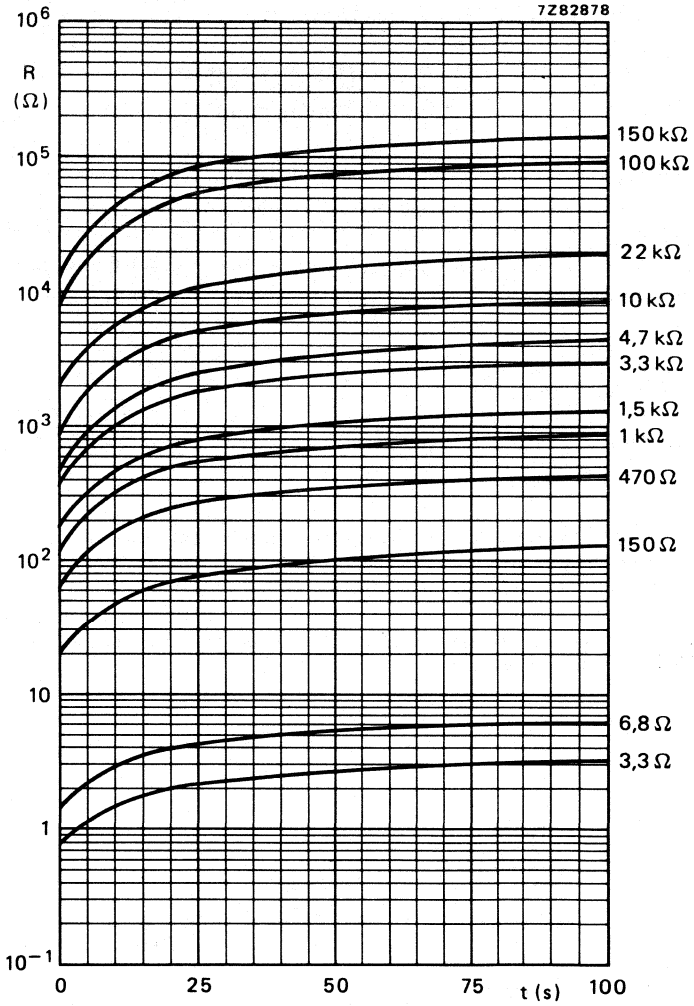

Fig. 8 Typical resistance/cooling time characteristic, $T_{\text{amb}} = +25^\circ\text{C}$, still air, $T_{\text{start}} = +85^\circ\text{C}$.

NTC THERMISTORS with mounting stud

QUICK REFERENCE DATA

Resistance value at +25 °C	3,3 Ω to 470 k Ω (E6 series)
B _{25/85} -value	2675 to 4650 K
Maximum dissipation	0,5 W
Dissipation factor	25 mW/K
Thermal time constant	20 s
Operating temperature range	
at zero power	-25 to +100 °C
at maximum power	0 to +55 °C

APPLICATION

Suitable for all kinds of applications, especially when a good insulation and/or a good thermal contact with the chassis is required.

DESCRIPTION

Disc thermistor with negative temperature coefficient mounted in the head of aluminium screws M4 and with two solid tinned copper wires.

MECHANICAL DATA

Outline drawing

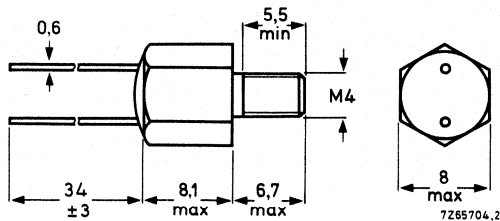

Fig. 1.

Marking

The last 4 digits of the catalogue number are printed on the stud according to Table 1.

Mass

1,5 g approx.

Mounting

By means of a washer and M4 nut supplied with the device.
Applied torque shall not exceed 1,2 Nm. Leads to be soldered.

Robustness of terminations

Tensile strength	10 N
Bending	5 N
Torque applied on screw	1,2 Nm max.

Soldering

Solderability	max. 240 °C, max. 4 s
Resistance to heat	max. 240 °C, max. 4 s

PACKAGING

100 thermistors in a cardboard box.

ELECTRICAL DATA

Maximum dissipation	0,5 W
Dissipation factor *	25 mW/K
Thermal time constant *	20 s approx.
Heat capacity	0,5 J/K approx.
Operating temperature range	
at zero power	-25 to +100 °C
at maximum power	0 to +55 °C
Dielectric withstanding voltage between terminals and screw	min. 100 V r.m.s.
Insulation resistance between terminals and screw at 100 V d.c.	min. 100 MΩ

See further Table 1.

For typical resistance/temperature and voltage/current characteristics, see pages 184/186 (type 2322 642 6....).

* Measured when screw mounted on an aluminium heatsink of 100 cm², thickness 1,5 mm, in still air,
T_{amb} = +25 °C.

Table 1 Catalogue number 2322 642 7....

suffix of catalogue number		R25	B25/85 value ± 5%	temperature coefficient at 25 °C
tol. 5%	tol. 10%	Ω	K	at 25 °C %/K
3338	2338	3,3	2675	-3,0
3478	2478	4,7	2750	-3,1
3688	2688	6,8	2800	-3,2
3109	2109	10	2875	-3,2
3159	2159	15	2950	-3,3
3229	2229	22	3025	-3,4
3339	2339	33	3100	-3,5
3479	2479	47	3150	-3,5
3689	2689	68	3225	-3,6
3101	2101	100	3300	-3,7
3151	2151	150	3375	-3,8
3221	2221	220	3475	-3,9
3331	2331	330	3575	-4,0
3471	2471	470	3650	-4,1
3681	2681	680	3725	-4,2
3102	2102	1 000	3825	-4,3
3152	2152	1 500	3975	-4,5
3222	2222	2 200	4125	-4,6
3332	2332	3 300	4250	-4,8
3472	2472	4 700	4350	-4,9
3682	2682	6 800	4400	-5,0
3103	2103	10 000	4275	-4,8
3153	2153	15 000	4200	-4,7
3223	2223	22 000	4275	-4,8
3333	2333	33 000	4350	-4,9
3473	2473	47 000	4400	-5,0
3683	2683	68 000	4450	-5,0
3104	2104	100 000	4500	-5,1
3154	2154	150 000	4550	-5,1
3224	2224	220 000	4600	-5,2
3334	2334	330 000	4625	-5,2
3474	2474	470 000	4650	-5,2

NTC THERMISTORS

disc

QUICK REFERENCE DATA

	2322 644 90004	2322 644 90005
Resistance value at +25 °C	82 Ω ± 20%	min. 15 Ω
Resistance at T _{amb} = +25 °C, and I _{rms} = 1,7 A and 2,2 A respectively	max. 0,85 Ω	max. 1 Ω
B _{25/85} -value	4650 K	3350 K
Maximum current (r.m.s.)	1,7 A	2,2 A
Dissipation factor	19 mW/K	17 mW/K
Thermal time constant	115 s	148 s
Operating temperature range		
at zero power	-25 to +155 °C	-25 to +155 °C
at maximum power	0 to +55 °C	0 to +55 °C

APPLICATION

For limiting surge current, soft start of motors and switch protection, preventing fuse blowing. ←

DESCRIPTION

This thermistor has a negative temperature coefficient. It consists of a disc with two tinned copper wires. The thermistor body is neither lacquered nor insulated.

MECHANICAL DATA

Outline drawing

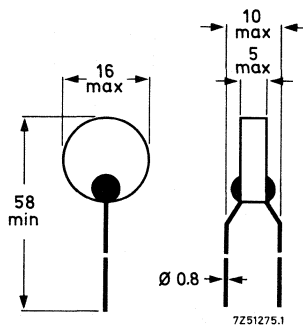

Fig. 1.

Marking

The thermistors are not marked.

Mass

Type 2322 644 90004 3,2 g approximately
Type 2322 644 90005 4 g approximately

Mounting

In any position by soldering. Do not solder within 10 mm from the thermistor body.

Robustness of terminations

Tensile strength 20 N
Bending 10 N

Soldering

Solderability max. 240 °C, max. 4 s
Resistance to heat max. 240 °C, max. 4 s

→ **PACKAGING**

100 thermistors in a cardboard box.

ELECTRICAL DATA

	2322 644 90004	2322 644 90005	
R at 25 °C	82 ± 20%	min. 15	Ω
R at T _{amb} = 25 °C, I _{rms} = 1,7 A	max. 0,85		Ω
R at T _{amb} = 25 °C, I _{rms} = 2,2 A		max. 1	Ω
B _{25/85} -value, approx.	4650	3350	K
Max. current (r.m.s.) at T _{amb} = +55 °C	1,7	2,2	A
Dissipation factor, approx.	19	17	mW/K
Thermal time constant, approx.	115	148	s
Heat capacity, approx.	2,2	2,5	J/K
Operating temperature range			
at zero power	-25 to +155	-25 to +155	°C
at maximum power	0 to +55	0 to +55	°C
Max. repetitive peak voltage			
50-60 Hz	345	380	V

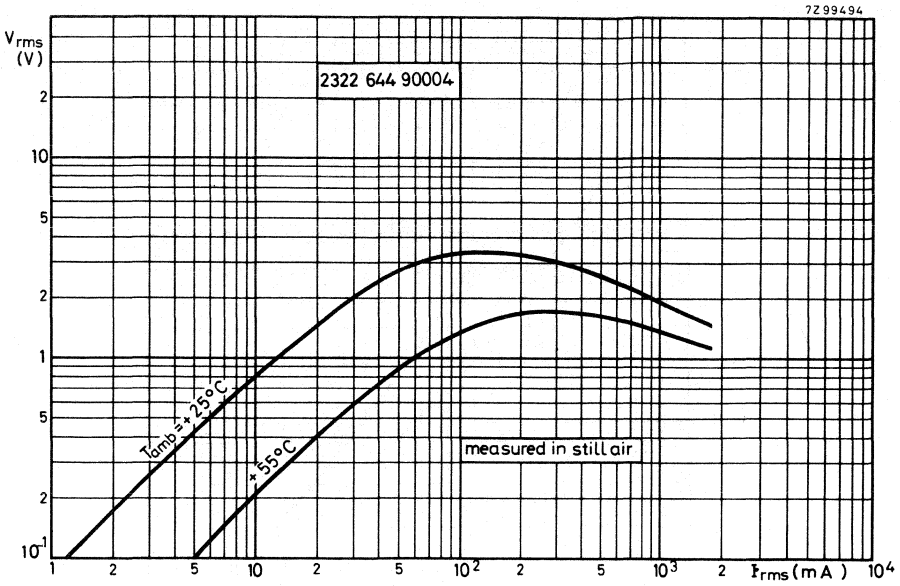

Fig. 2 Typical voltage/current characteristics.

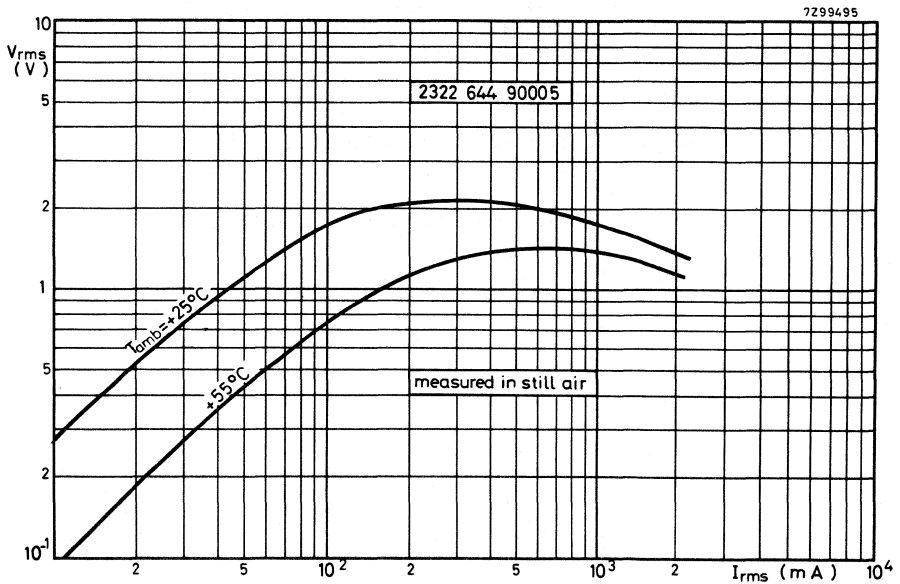

Fig. 3 Typical voltage/current characteristics.

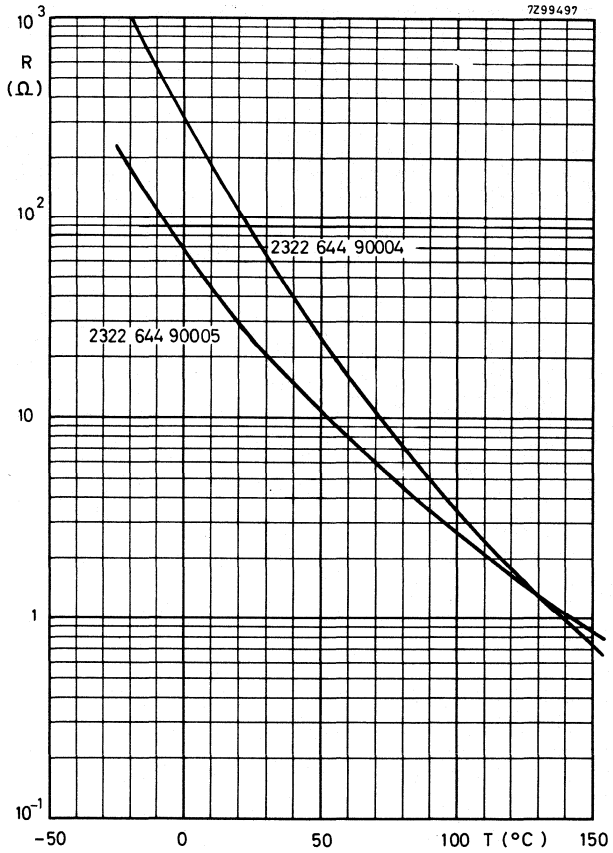

Fig. 4 Typical resistance/temperature characteristics.

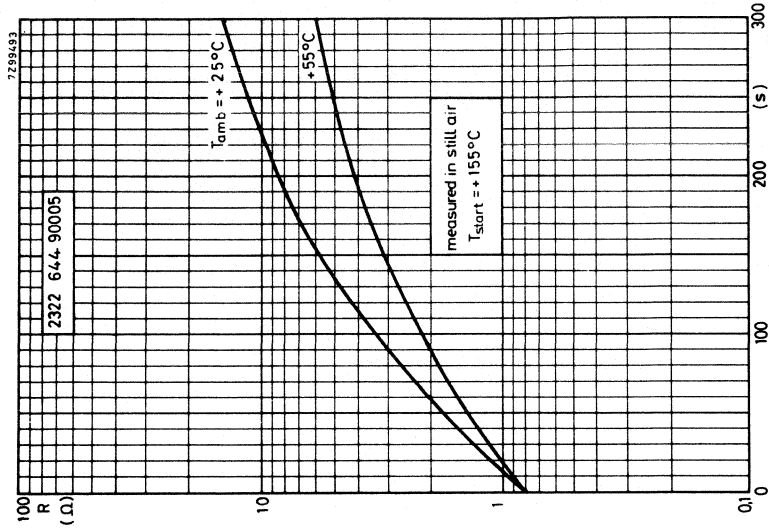

Fig. 7 Typical resistance/time (Cooling) characteristics.

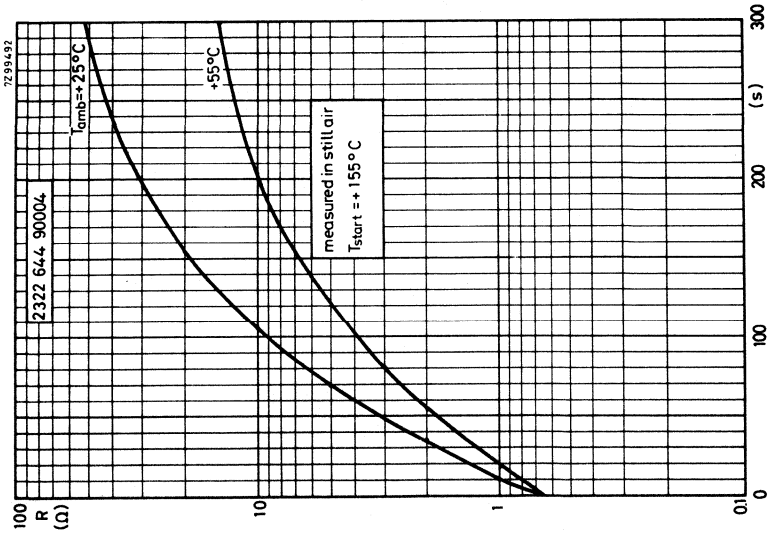

Fig. 6 Typical resistance/time (Cooling) characteristics.

NTC THERMISTOR

disc without leads

QUICK REFERENCE DATA

Resistance value at +25 °C	5 Ω \pm 20%
Resistance value at $I_{\text{rms}} = 2,2 \text{ A}$	max. 0,5 Ω
B _{25/85} -value	2975 K
Maximum current (r.m.s.)	8 A
Operating temperature range at zero power	-25 to +155 °C
at maximum power	0 to +55 °C

APPLICATION

For limitation of surge current.

DESCRIPTION

Disc thermistor with negative temperature coefficient, provided with reinforced contacts.

MECHANICAL DATA

Outline drawing

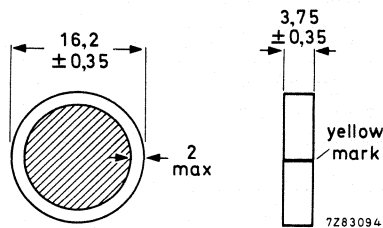

Fig. 1.

Marking	yellow stripe, see Fig. 1.
Mass	4,2 g approximately.
Mounting	In any position by clamping.
Impact	Free fall, 0,1 m.
Inflammability	Uninflammable

PACKAGING

10 preformed sheets of polystyrene containing 75 items in a cardboard box. Resistance value and catalogue number are printed on the box.

ELECTRICAL DATA

Unless otherwise specified, measured according to IEC publication 539

Resistance value at +25 °C	5 Ω ± 20%
Resistance value at $I_{rms} = 2,2$ A	max. 0,5 Ω
B _{25/85} -value	2975 K
Temperature coefficient	-3,35%/K
Maximum current (r.m.s.)	8 A
Operating temperature range	
at zero power	-25 to +155 °C
at maximum power	0 to +55 °C

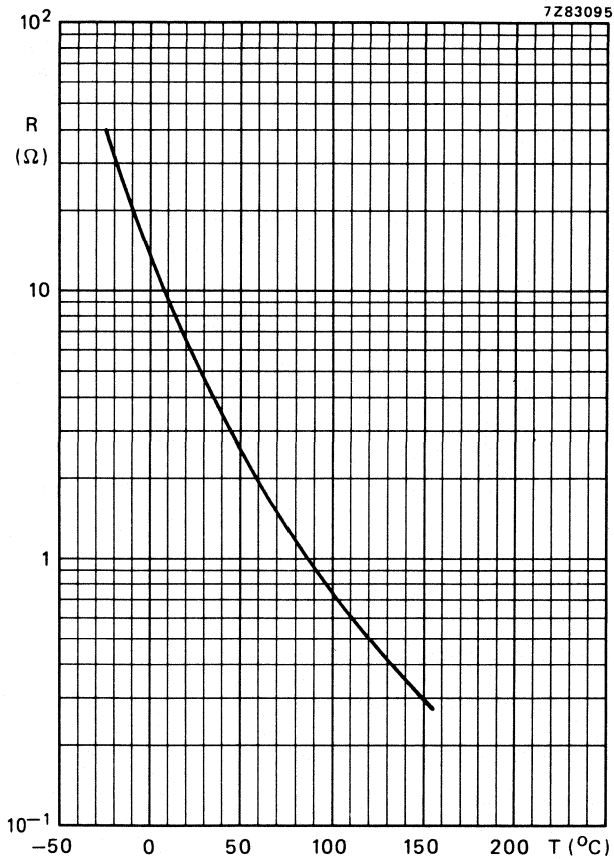

Fig. 2 Typical resistance/temperature characteristic.

DEVELOPMENT DATA

This data sheet contains advance information and specifications are subject to change without notice.

NTC 645 SERIES

NTC THERMISTORS

Sensors

QUICK REFERENCE DATA

Resistance at 25 °C	1 to 10 k Ω
B _{25/75} value	3965 K
Maximum dissipation	0,1 to 0,75 W
Operating temperature range at zero power	-40 to 110 °C
at maximum power	0 to 55 °C

DESCRIPTION

These thermistors have a negative temperature coefficient, they consist of a disc with two tinned solid copper wires. The range includes some 20 versions which have been made from one base material, selected for its extremely stable characteristics. The various R₂₅ values are obtained by dimensional variations. The thermistors have a non-flammable coating of a protective lacquer which is resistant against most commonly used cleaning solvents according to IEC 68-2-45.

APPLICATION

For accurate temperature sensing, measurement and control up to 110 °C. The larger types (dia. 6 and 8,5 mm) are for general purpose application.

MECHANICAL DATA

Outlines

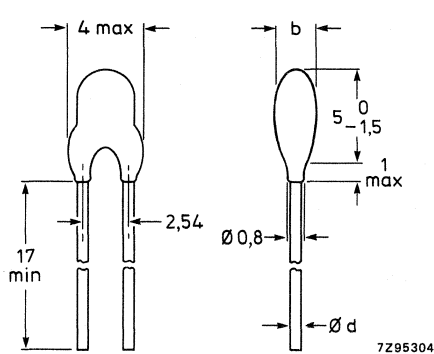

Fig. 1 0,1 W types.

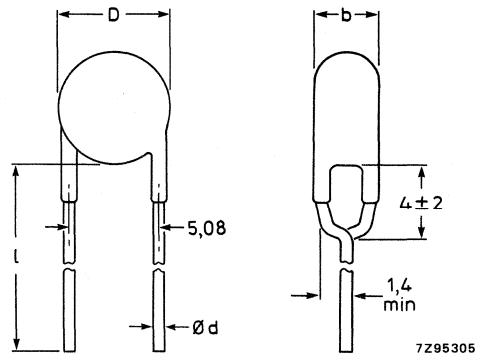

Fig. 2 0,25 and 0,75 W types.

For dimensions D, b, d and l see Table 1.

NTC 645 SERIES

MECHANICAL DATA (continued)

Marking	: none	
Mass	: see Table 1	
Mounting	: in any position by soldering	
Robustness of terminations		
Tensile strength		10 N
Bending		5 N
Soldering		
Solderability		max. 240 °C, max. 4 s
Resistance to heat		max. 265 °C, max. 11 s
Impact		
Free fall		1 m
Inflammability		
Non-inflammable according to IEC publication 695-2-2 (1980, needle flame)		

PACKAGING

The thermistors are packed in cardboard boxes, the smallest packing quantities are:

2322 645 0	}	500
2322 645 2		
2322 645 4		250

ELECTRICAL DATA

Unless otherwise specified, measured according to IEC publication 539 see also Table 1.

B _{25/75} value	3965 ± 1,25 %
Operating temperature range, see Fig. 3	
at zero power	-40 to 110 °C
at maximum power	0 to 55 °C

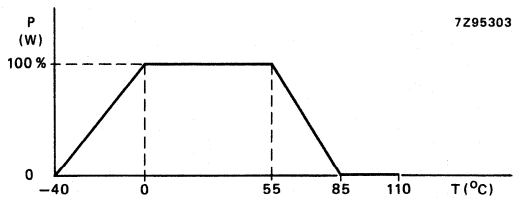

Fig. 3 Derating curve.

Table 1 Catalogue number 2322 645

suffix of catalogue number		R ₂₅	dissipation max.	δ appr.	τ appr.	resp. time appr.*	mass	Fig.	dimensions (mm)			
tol. ± 5%	tol. ± 10%	kΩ	W	mW/K	s	s	g		D	d	b	l
03502	02502	5	0,1	6,6	7	0,95	0,12	1	—	0,6	2,2	—
03602	02602	6	0,1	6,6	8	1,10	0,16	1	—	0,6	2,3	—
03802	02802	8	0,1	6,6	8,5	1,15	0,17	1	—	0,6	2,5	—
03103	02103	10	0,1	6,6	9,5	1,20	0,18	1	—	0,6	2,8	—
23202	22202	2	0,25	9,2	16	1,9	0,36	2	6	0,6	2,8	30,5
23252	22252	2,5	0,25	9,2	18	2,0	0,37	2	6	0,6	3,1	30,5
23302	22302	3	0,25	9,2	20	2,4	0,44	2	6	0,6	3,3	30,5
23502	22502	5	0,25	9,2	25	3,2	0,47	2	6	0,6	4,4	30,5
43102	42102	1	0,75	9,5	30	3,1	0,57	2	8,5	0,6	3,0	28
43202	42202	2	0,75	11,0	43	4,5	0,80	2	8,5	0,6	4,1	28

* Response time in silicone oil MS 200/50. This is the time the sensor needs to reach 63,2% of the total temperature difference when subjected to a temperature change, in this case from 25 °C in air to 85 °C in oil.

These thermistors have a narrow tolerance on the B value, the result of which is to provide a very small tolerance on the nominal resistance value over a wide temperature range. For this reason the usual graphs of R = f(T) are replaced by table 2, together with a formula with which the characteristics can be calculated with a high precision.

Formula to determine nominal resistance values.

The resistance values at intermediate temperatures can be calculated using the "Steinhert and Hart" equation:

$$R_T = \left(\frac{R_{25}}{10000} \right) \cdot e^{\left\{ \sqrt[3]{\sqrt{E^2 + D} - E} - \sqrt[3]{\sqrt{E^2 + D} + E} \right\}}$$

in which D = 4,76919 x 10⁸ and

$$E = \frac{1,14102 - 10^3/T}{1,9786 \times 10^{-4}}$$

T = temperature in K.

Determination of the resistance/temperature deviation from nominal

The complete resistance deviation is obtained by combining the "R₂₅ tolerance" and the "resistance deviation due to B tolerance".

Let X = R₂₅ tolerance;

Y = resistance deviation due to B tolerance;

Z = complete resistance deviation; then:

$$Z = [(1 + X/100) \times (1 + Y/100) - 1] \times 100 \text{ or } Z = X + Y \text{ (approximation)}$$

TC = temperature coefficient;

ΔT = temperature deviation, so:

$$\Delta T = \frac{Z}{TC}$$

Example:

at 0 °C: let X = 5%; Y = 1,5% and TC = 5,08%/K (see table 2)

$$Z = (1,05 \times 1,015 - 1) \times 100 = 6,575\% \text{ or } 5\% + 1,5\% = 6,5\% \text{ (approximation)}$$

$$\Delta T = 6,575/5,08 = 1,3 \text{ }^\circ\text{C}$$

So, an NTC having R₂₅ = 10 kΩ has a value of 32510 Ω between -1,3 °C and +1,3 °C, as also shown in Fig. 4.

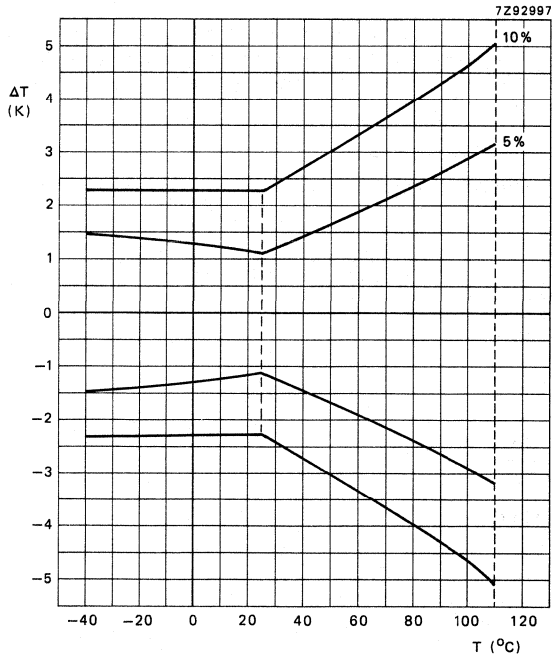

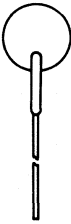

Fig. 4 Temperature deviation (in K) over the range from -40 °C to 110 °C for both 5% and 10% thermistors.

temperature °C	ratio R _T /R ₂₅	R deviation due to B tol. %	temperature coefficient %/K	resistance (kΩ) for types 2322 645 followed by											
				42102 43102	22202 23202 42202 43202	22252 23352	22302 23302	02502 03502	02602 03602	02802 03802	02103 03103				
-40	32,84	4,5	6,57	32,84	65,68	82,10	98,52	164,2	197,0	262,7	328,4				
-35	23,77														
-30	17,39	3,7	6,15	17,39	34,78	43,48	52,17	86,95	104,3	139,1	173,9				
-25	12,85														
-20	9,589	2,9	5,76	9,589	19,18	23,97	28,77	47,95	57,53	76,71	95,89				
-15	7,223														
-10	5,489	2,2	5,40	5,489	10,98	13,72	16,47	27,45	32,93	43,91	54,89				
5	4,207														
0	3,251	1,5	5,08	3,251	6,502	8,128	9,753	16,26	19,51	26,01	32,51				
5	2,531														
10	1,986	0,9	4,78	1,986	3,972	4,965	5,958	9,930	11,92	15,88	19,86				
15	1,569														
20	1,249	0,3	4,50	1,249	2,498	3,122	3,747	6,245	7,494	9,992	12,49				
25	1,000	0,0	4,37	1,000	2,000	2,500	3,000	5,000	6,000	8,000	10,00				
30	0,8060	0,3	4,25	0,8060	1,612	2,015	2,418	4,030	4,836	6,448	8,060				
35	0,6536														
40	0,5331	0,8	4,02	0,5331	1,066	1,333	1,599	2,666	3,199	4,265	5,331				
45	0,4372														
50	0,3606	1,3	3,80	0,3606	0,7212	0,9015	1,082	1,803	2,164	2,885	3,606				
55	0,2989														
60	0,2490	1,8	3,60	0,2490	0,4980	0,6225	0,7470	1,245	1,494	1,992	2,490				
65	0,2085														
70	0,1753	2,2	3,42	0,1753	0,3506	0,4382	0,5259	0,8765	1,052	1,402	1,753				
75	0,1481														
80	0,1256	2,6	3,25	0,1256	0,2512	0,3140	0,3768	0,6280	0,7536	1,005	1,256				
85	0,1070														
90	0,9155	3,0	3,09	0,09155	0,1831	0,2289	0,2747	0,4578	0,5493	0,7324	0,9155				
95	0,07861														
100	0,06775	3,4	2,94	0,06775	0,1351	0,1694	0,2033	0,3388	0,4065	0,5420	0,6775				
105	0,05860														
110	0,05086	3,8	2,80	0,05086	0,1017	0,1272	0,1526	0,2543	0,3052	0,4069	0,5086				
115	0,04429														
120	0,03870	4,2	2,67	0,03870	0,0774	0,09675	0,1161	0,1935	0,2322	0,3096	0,3870				
125	0,03392														

POSITIVE TEMPERATURE COEFFICIENT THERMISTORS (PTC)

TYPE SELECTION

	maximum voltage	R_{25} Ω	switch temperature $^{\circ}\text{C}$	dissipation factor mW/K	temperature coefficient $\%/K$	catalogue number	page
DISC 	460 V (r.m.s.)	70 to 100	120	11,5	35	2322 662 93006	174
	25 V (d.c.)	≥ 4000	70 to 150		18 to 38	2322 672 91026 to 2322 672 91035	221
DISC with leads 	16 V (d.c.)	$\leq 0,6$	85	27	10	2322 664 91086	215
	25 V (d.c.)	30 to 250	70 to 150	5,7	18 to 38	2322 672 91002 to 2322 672 91035	301
	25 V (d.c.)	50 and 60 $\pm 30\%$	30 to 105	7	7 to 40	2322 660 91006 to 2322 660 91009	152
	25 V (d.c.)	250 $\pm 25\%$	6	6	5	2322 660 91001	149
	40-50 V (d.c.)	30 to 50 $\pm 15 \Omega$	25 to 110	6 to 8,5	9 to 75	2322 661 91002 to 2322 661 91005	163
	180 V (d.c.)	36 to 50	115	13	35	2322 662 91001	168
245 V (r.m.s.)	750 to 1500	115	7	26	2322 660 93001	159	
265 V (r.m.s.)	45 to 60	75	20	20	2322 662 93036	177	
265 V (r.m.s.)	100 $\pm 20\%$	75	15	35	2322 662 93066	181	
25 V (d.c.)	≥ 4000	70 to 150	5,7	18 to 38	2322 672 91002 to 2322 672 91011	221	

Overload protection	56 V (d.c. and 265 V (r.m.s.))					2322 66 .	254 to 303
Loudspeaker protection	18 V (r.m.s.) 18 V (r.m.s.)	max. 1,1 max. 1,1	100 140	6 8		2322 662 91016 2322 663 91006	171 211
Motor protection	15 V (d.c.)	30 to 250	68 to 137	7	18 to 38	2322 672 92045 to 2322 672 92053	229
DUAL PTC for degaussing	145 V (r.m.s.) 265 V (r.m.s.) 265 V (r.m.s.) 265 V (r.m.s.)	10 and 400 to 2400 40 and 3000 35 and 1000 40 and 3000	70 and 170 65 and 170 65 and 170	12,5	16 and 20 26 and 19	2322 662 98013 2322 662 98009 2322 662 98011 2322 662 98018	201 185 193 205
DISC for compensation of telephone line variations	33 V (d.c.) 34 V (d.c.)	115 ± 25 120 ± 30	97 145	3,9	10 8	2322 672 98001 2322 670 90003	237 219

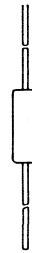
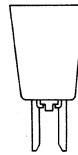
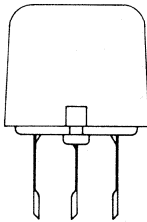
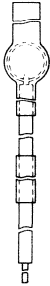

PTC THERMISTORS

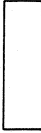
type	voltage range r.m.s. V	max. inrush power W	operating temp. after 20 min °C	measured at V	diameter mm	catalogue number	page
HEATING ELEMENT 	100 to 265	500	—	220	12,7	2322 680 04022	255
	100 to 265 100 to 265 100 to 265 100 to 145 100 to 265 100 to 145 100 to 265	1000 1000 1000 1000 1000 1000 1000	160 160 215 215 160 160 220	220 220 220 220 220 220 220	14,8 10,8 12,7 12,7 12,7 12,7 12,7	2322 680 00031 2322 680 03001 2322 680 04001 2322 680 04002 2322 680 04003 2322 680 04004 2322 680 04022	243 245 247 249 251 253 255
	145 and 265					2322 680 93021 to 2322 680 93037	257

INTRODUCTION

Positive Temperature Coefficient (PTC) thermistors are resistors with a high positive temperature coefficient of resistance. They differ from NTC thermistors in the following aspects:

- The temperature coefficient of a PTC thermistor is positive only *between certain temperatures*, outside this range the temperature coefficient is either zero or negative.
- The absolute value of the temperature coefficient of PTC thermistors is usually much higher than that of NTC thermistors.

PTC thermistors are used as current limiters, temperature sensors and protectors against overheating in equipment such as electric motors. They are also used as level indicators, time delay devices, thermostats, compensation resistors, etc. See chapter 'Applications'.

PTC thermistors are prepared from BaTiO_3 , or solid solutions of BaTiO_3 and SrTiO_3 in a similar way as NTC thermistors. Extra electrons on the Ti-ions are created by the introduction of foreign ions having a different valency. In these compounds there are two possibilities: substitution of trivalent ions like La^{3+} or Bi^{3+} for Ba^{3+} or substitution of pentavalent ions like Sb^{5+} or Nb^{5+} for Ti. Both methods lead to identical results. If prepared in the absence of oxygen, these semiconductors have a weakly negative temperature coefficient. A strong positive temperature coefficient is obtained by firing the ceramic samples in an oxygen-rich atmosphere. This is caused by the penetration of oxygen along pores and crystal boundaries during cooling after the firing process. The oxygen atoms, absorbed on the crystal surfaces attract electrons from a thin zone of the semiconducting crystals. In this way electrical potential barriers are formed consisting of a negative surface charge with, on both sides, thin layers having a positive space charge resulting from the now uncompensated foreign ions. These barriers cause an extra resistance of the thermistor.

$$R_b \propto \frac{1}{a} e^{eV_b/kT} \quad (\alpha = \text{directly proportional to})$$

Here 'a' represents the size of the crystallites, thus $\frac{1}{a}$ is the number of barriers per unit length of the thermistor. V_b represents the electrical potential of the barriers. As V_b is inversely proportional to the value of the dielectric constant of the crystals it is clear that R_b is extremely sensitive to variations of the dielectric constant. Such a variability of the dielectric constant is a special property of materials with a ferroelectric nature like BaTiO_3 and its solid solutions. Above their ferroelectric Curie temperature θ the relative dielectric constant decreases with temperature according to

$$\epsilon_r = \frac{C}{T - \theta}$$

where C has a value of approximately 10^5 K. As a result the resistivity increases steeply just above the Curie temperature. Below the Curie temperature the barriers are weak or absent, partly as a result of the high effective dielectric constant of BaTiO_3 in strong fields and partly as a result of the spontaneous polarization of the crystals which may compensate the boundary charges.

At very high temperatures, i.e. above 160 to 200 °C the electrons captured at the boundaries are gradually liberated, causing the potential barriers to decrease in strength. This means that the PTC loses its properties and may eventually act as an NTC if the temperature becomes too high. Therefore the applications of PTC thermistors are restricted by a certain temperature limit.

As the PTC effect is caused by crystal boundary barriers the extra resistance R_b is shunted by a high parallel capacitance C_b . This leads to a frequency dependence of extra impedance Z_b up to 5 MHz. The characteristic properties described in the following paragraphs are thus restricted to this frequency range.

ELECTRICAL PROPERTIES

RESISTANCE/TEMPERATURE CHARACTERISTICS

Figure 1 shows typical resistance/temperature characteristics of an NTC and a PTC thermistor.

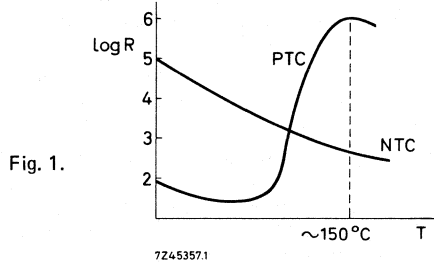

VOLTAGE/CURRENT CHARACTERISTICS

Static voltage/current characteristics show the current limiting ability of PTC thermistors. Up to a certain voltage the V/I characteristic follows Ohm's law, but the resistance increases when the PTC is heated so much by the current it is carrying that its temperature reaches the switch temperature. See Fig. 2. Of course the V/I characteristic depends on the ambient temperature and on the heat transfer coefficient to the ambience. In Fig. 2 the characteristic is plotted on a linear scale. In practice, however, logarithmic scales are used more often, see Fig. 3. PTC thermistors show some voltage dependency. At higher voltages the resistance is somewhat lower than expected. It is possible to calculate accurately the top of the V/I characteristic if the R/T characteristic and the dissipation constant are known:

The power dissipation is: $P = I^2 R$

Thus a small increase in P: $\Delta P = 2 IR \Delta I + I^2 \Delta R$

At the top of the V/I curve $\Delta I_p = 0$, thus:

$$\Delta P_p = I_p^2 \Delta R_p \quad (\text{p indicates that the values are taken at the top of the V/I characteristic}).$$

Also $\Delta P = D \Delta T$, thus:

$$\Delta P_p = D \Delta T_p = I_p^2 \Delta R_p$$

or $\frac{\Delta T_p}{\Delta R_p} \cdot D = I_p^2$

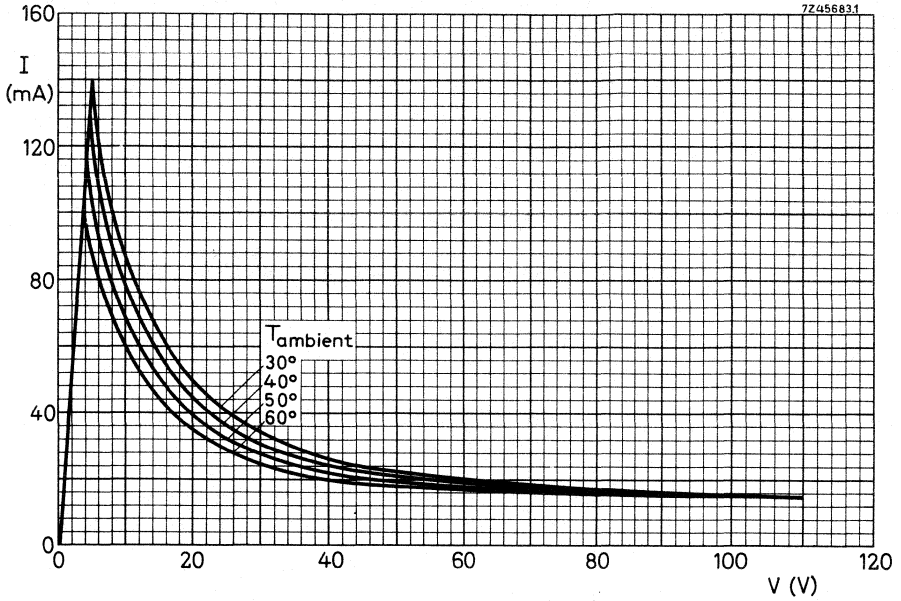

Fig. 2 Voltage/current characteristics of a PTC thermistor on a linear scale, with ambient temperature as a parameter.

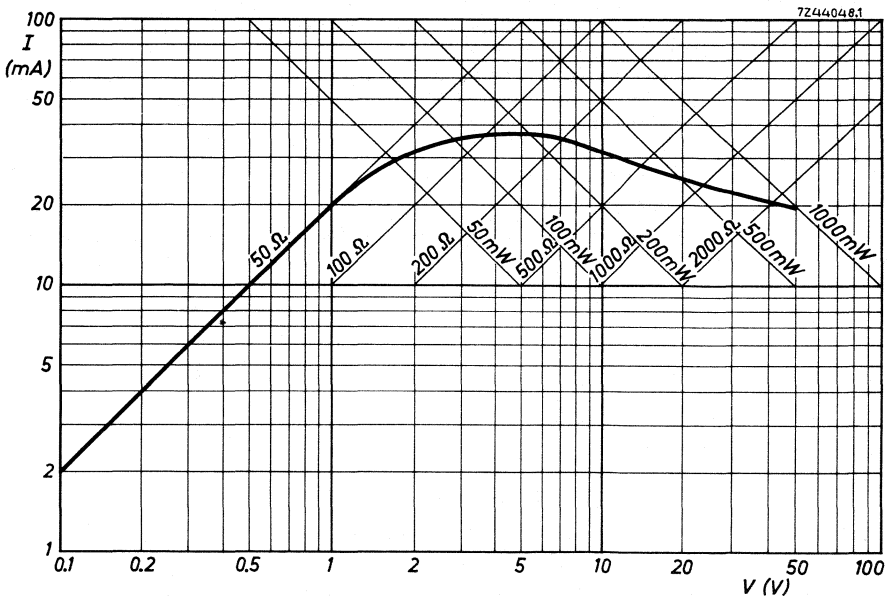

Fig. 3 Voltage/current characteristic on logarithmic scale.

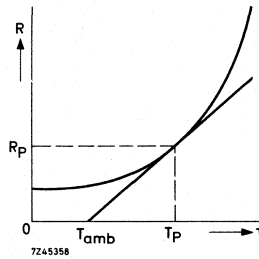

Fig. 4 Part of the resistance/temperature characteristic on a linear scale.

From Fig. 4:

$$\frac{\Delta T_p}{\Delta R_p} = \frac{T_p - T_{amb}}{R_p}$$

so

$$I_p = \sqrt{\frac{D(T_p - T_{amb})}{R_p}}$$

For given ambient temperature (T_{amb}) and D , R_p and T_p can easily be found; see Fig. 4.

The calculation shows that if D is increased n times (e.g. by a heatsink, or ambience with better heat conductivity) I_p increases \sqrt{n} times.

PTC THERMISTOR IN SERIES WITH A LOAD

From the voltage/current characteristic it can be shown that because of the non-linearity of the PTC-curve three working points are possible when a load R is connected in series with the PTC. See Fig. 5. The characteristic of the load is a straight line intersecting the voltage co-ordinate at V_a , the supply voltage. P_1 and P_2 are stable working points; P_3 is unstable.

When the voltage V_a is applied to the series connection, equilibrium will be reached at P_1 , a point with a relatively high current. P_2 can only be reached when the top of the V/I curve comes below the load characteristic. This may happen in the following cases:

- V_a increases, see Fig. 6;
- the ambient temperature increases, see Fig. 7;
- the load resistance decreases, see Fig. 8.

The PTC thermistor is thus an excellent protector, limiting the load to a safe value if supply voltage, temperature or current exceeds a critical value.

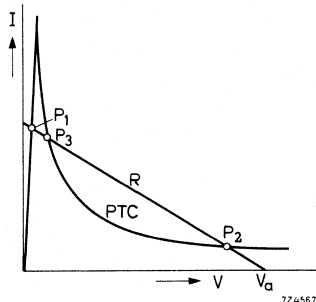

Fig. 5 PTC thermistor in series with a load showing the possible working points.

Fig. 6 PTC thermistor in series with a load showing the influence of the supply voltage V_a .

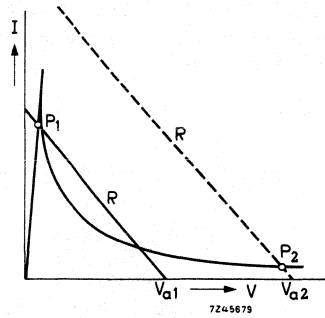

Fig. 7 PTC thermistor in series with a load showing the influence of the ambient temperature.

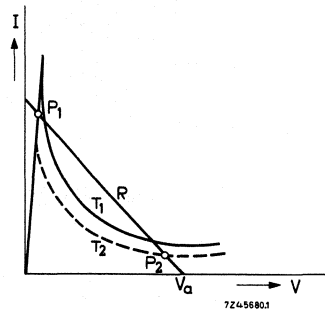
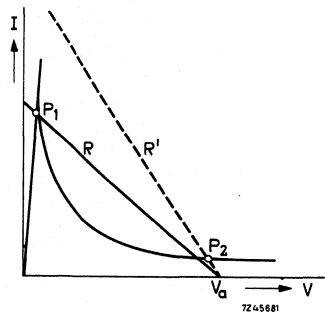

Fig. 8 PTC thermistor in series with a load showing the influence of the load resistance.



CURRENT/TIME CHARACTERISTICS

If a PTC thermistor is connected in series with a resistance of such a value that the top of the V/I curve lies under the load line, the PTC will heat up till the stable working point P_2 is reached (Fig. 9). The time it takes to reach this point depends very much on the value of the load R (Fig. 10) and the ambient temperature.

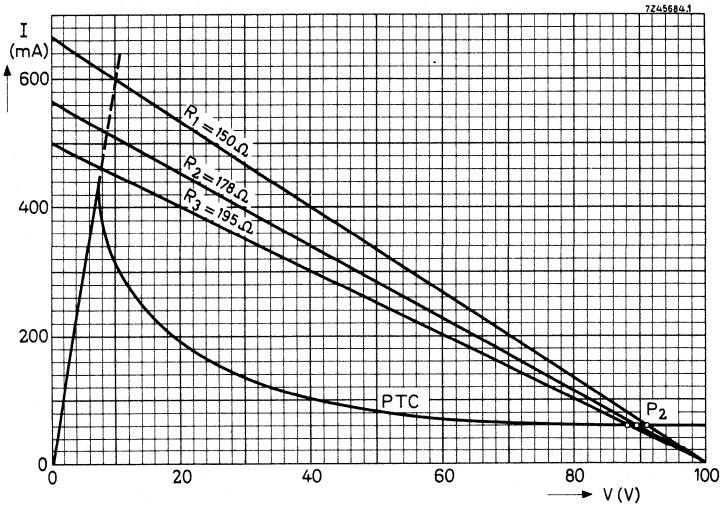

Fig. 9 PTC thermistors in series with different resistors.

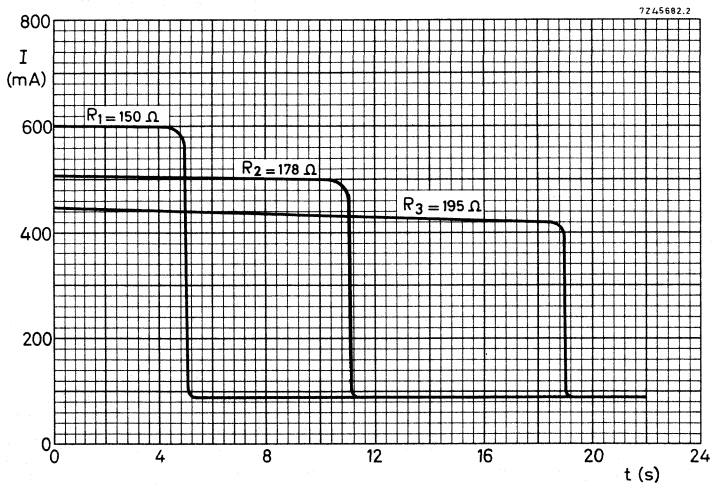

Fig. 10 Current/time characteristics showing the influence of the load.

EXPLANATION OF TERMS

Switch temperature (T_s)

The switch temperature T_s is the higher of the two temperatures at which the resistance R_s is twice the minimum resistance R_{min} (see Fig. 11).

So, at $T_s > T_{Rmin}$: $R_s = 2 R_{min}$.

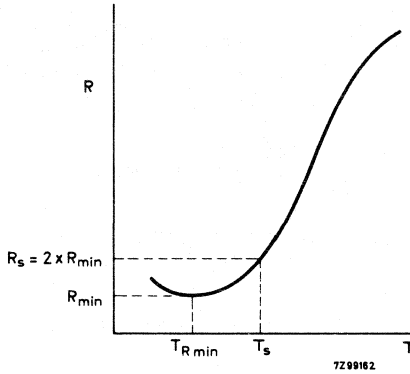

Fig. 11.

Temperature coefficient (α)

The temperature coefficient $\alpha = \frac{1}{R} \frac{dR}{dT}$.

For R-T curves plotted on a log R-lin T scale:

$$\alpha = \frac{d \ln R}{dT} = \frac{1}{0,4343} \cdot \frac{d \log R}{dT}$$

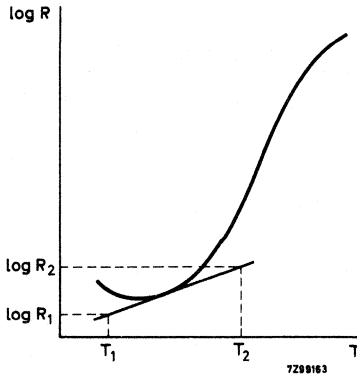

Fig. 12.

α can be calculated from

$$\alpha = \frac{100}{0,4343} \cdot \frac{\log R_2 - \log R_1}{T_2 - T_1} \% / K$$

where R_1 and R_2 are points on the tangent and T_1 and T_2 are the corresponding temperatures.

PTC THERMISTORS

In the data sheets the maximum temperature coefficient is given, this is the α measured at the point of inflection of the log R-in T characteristic, i.e. the point where $\frac{d^2 \log R}{dT^2} = 0$, see Fig. 13.

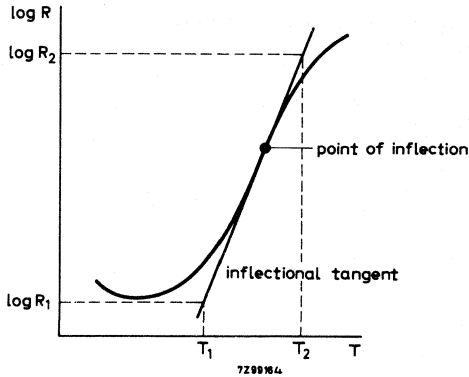

Fig. 13.

When one resistance decade is taken ($R_2 = 10 R_1$) the formula reduces to

$$\alpha = \frac{100}{0,4343} \cdot \frac{1}{T_2 - T_1} \% / K$$

Thermal time constant (τ)

The thermal time constant represents the time required for a thermistor to change 63,2% of the total difference between its initial and final body temperatures when subjected to a step function change in temperature under zero-power conditions.

The τ given in the data is found as follows (for $T_s > 25$ °C):

Measure T_1 , the temperature of the PTC at V_{max} , at an ambient temperature of $T_0 = 25$ °C; T_s is known, so τ can be calculated from:

$$\tau = \frac{t}{\ln \frac{(T_1 - T_0)}{(T_s - T_0)'}}$$

where t is the time required for cooling the PTC from T_1 to T_s in still air at 25 °C.

Voltage dependence

PTC thermistors show a voltage dependence. This effect can be explained with the aid of a parallel connection of an "ideal PTC" having no voltage dependence and an "ideal VDR" for which the relation between voltage and currents is:

$$V = C \cdot I^\beta$$

See Fig. 14.

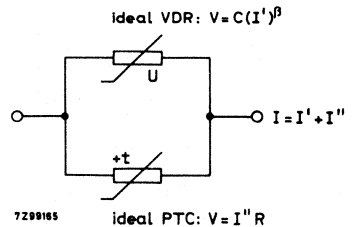

Fig. 14.

Plotted on a log I - log V scale at an arbitrary constant temperature the ideal PTC and the ideal VDR characteristics are straight lines, see Fig. 15.

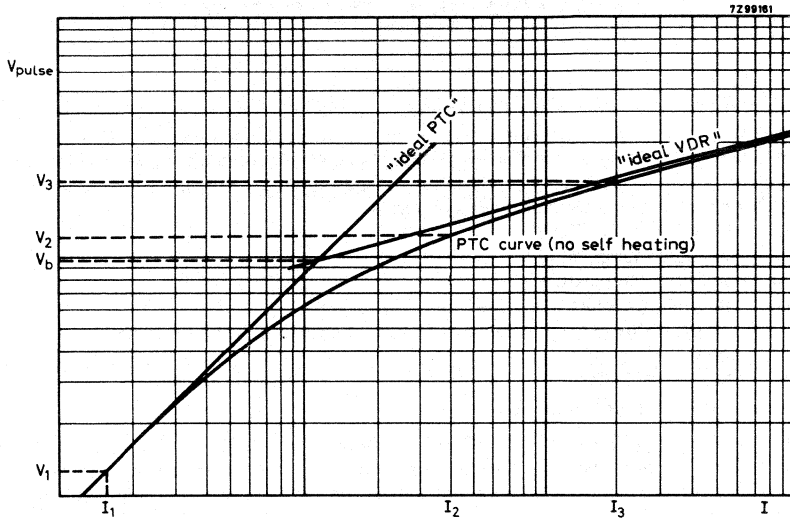

Fig. 15.

These lines coincide with the PTC curve (measured under pulse conditions to avoid internal heating) at low voltages where the ohmic behaviour is the deciding factor, and at high voltages where the VDR effect becomes more significant.

Two aspects of the voltage dependence are specified in the data sheets:

Balance voltage (V_b)

Where the two straight lines intersect, the current through the ideal PTC is equal to the current through the ideal VDR. The voltage at which this occurs is called the balance voltage V_b and is specified at a certain temperature.

Voltage dependence (β)

The β of the ideal VDR is a measure of the voltage dependence of the PTC and can be calculated using the formula:

$$\beta = \frac{\log V_3/V_2}{\log (I_3 - V_3/R)/(I_2 - V_2/R)}$$

where V_3 and V_2 are pulse voltages $> V_b$ and $R = \frac{V_1}{I_1}$, measured at $V_1 \leq 1,5$ V (d.c.).

β is also specified at a certain temperature.

V_b and β are useful parameters for estimating the voltage dependence of a particular PTC thermistor.

HOW TO MEASURE PTC THERMISTORS

As PTC thermistors often show a very high temperature coefficient especially at high temperatures, measurements at these high temperatures must be carried out with particular care. Even an error of 0,1 K can give an error in resistance of a few percent. Specially calibrated thermometers have to be used. Stem correction has to be applied; deviations of more than 0,1 K may result if it is not used.

The stem correction formula for fluid thermometers is:

$$T_c = T_o + F \cdot L (T_o - T_m),$$

where: T_c = corrected temperature;

T_o = observed temperature;

T_m = mean temperature of exposed stem;

L = length of the exposed column in K above the surface of the substance whose temperature is being determined;

F = correction factor.

F is approximately 0,00016 for a mercury thermometer.

For example with $T_o = 110$ °C, $T_m = 70$ °C and $L = 50$ K: $T_c = 110,32$ °C, thus without stem correction an error of more than 0,3 K would have been made. It is also necessary to measure the resistance with a voltage below 2 V in order not to heat the PTC and also to diminish voltage-dependent effects.

TOLERANCES

The resistances of standard PTC thermistors are specified at

(1) 25 °C;

(2) A temperature above the switch temperature.

The switch temperature is also given.

For each standard type tolerances are specified for R_{25} and the high-temperature resistance. The tolerance on switch temperature is not specified; normally it is only a few K.

Special types are often specified according to the requirements for the particular application. The PTC thermistors for motor control, for instance, can be specified at a high temperature with a rather close tolerance, while the tolerance below the switch temperature, being less important, is much greater. PTC thermistors for current limiting applications are in most cases specified in terms of voltage and current.

It will be clear that the specification and the tolerances of PTC thermistors depend on the application, and are not limited to the standard range published in this book.

APPLICATIONS

The applications of PTC thermistors can be classified in two main groups:

- Applications where the temperature of the PTC is primary determined by the temperature of the ambient medium.
- Applications where the temperature of the PTC is primary determined by the current through the PTC thermistor.

The first group comprises applications such as temperature-measurement and control and circuits for protection against excessive temperatures (e.g. motor protection.)

The second group includes applications such as current stabilization and current sensitive switching or overload protection, relay retardation, fluid-level indication and circuits for protection against over-voltages and short circuits. Also heating applications.

ADVICE

Do not apply a voltage above V_{\max} to the PTC, since this may destroy the thermistor.

Do not connect PTC thermistors in series in order to obtain higher voltages or wattages: this may cause one PTC to heat up faster than the other(s) resulting in too high a voltage across this particular PTC.

If special PTC characteristics are required which cannot be found in this book please specify your requirements as they can perhaps be fulfilled by one of our non-listed types.

APPLICATION EXAMPLES

Protection against over-load or current sensitive switching

As soon as the current increases the PTC limits it to a safe value.

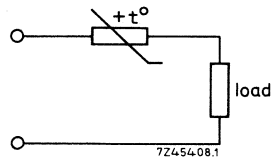

Spark suppression

A PTC across the switch acts as a spark suppressor. When the switch opens the low resistance of the cold PTC prevents sparking.

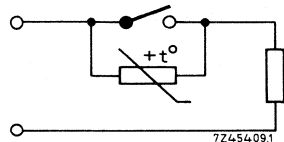

PTC THERMISTORS

Current stabilization

By using a parallel resistor a current stabilization circuit is obtained that compensates slowly varying supply voltages.

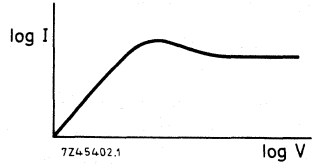
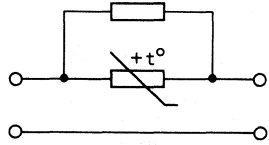

72454.02.1

Delaying action relays

A certain time after applying the voltage the relay is activated.

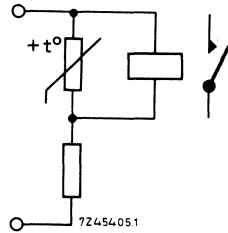

72454.05.1

Temperature protection of electric motors

As soon as one or more windings become too hot the motor is switched-off.

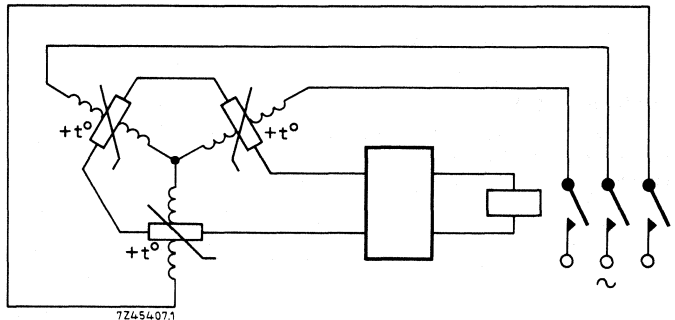

72454.07.1

Alarm installation

The PTC reacts on ambient temperature (too low or too high).

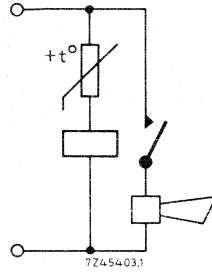

Time delay circuit

When the button is pressed the relay is activated and the lamp lights up. After some time the relay falls off due to the increase in resistance of the PTC.

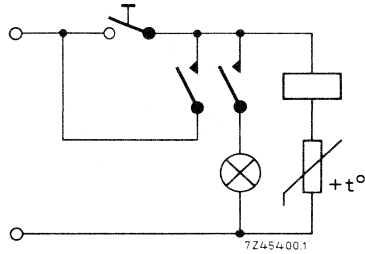

Liquid-level indication

The PTC thermistors above the fluid-level will be heated to a temperature above T_{switch} . When immersed they are cooled so that their resistance reduces.

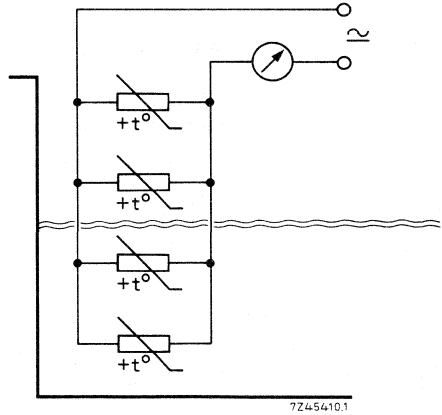

Temperature compensation of transistor circuits

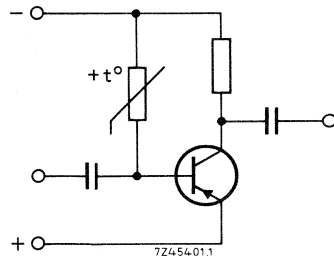

PTC THERMISTORS

Thermostatically-controlled heating circuits

Two principal circuits are possible. In the first circuit the PTC thermistor acts as a control element and as a heater at the same time, while in the second circuit it functions only as a control element.

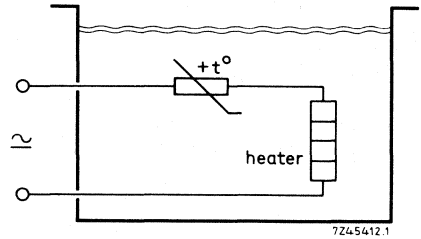
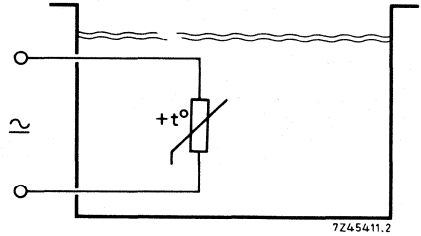

Protection of a stalled electric motor against overheating.

The increased current heats the PTC to its switch temperature. As a result the total dissipated power is reduced to a safe value.

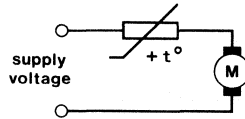

Loudspeaker protection

Protection of squawker and tweeter in a 3-way loudspeaker system.

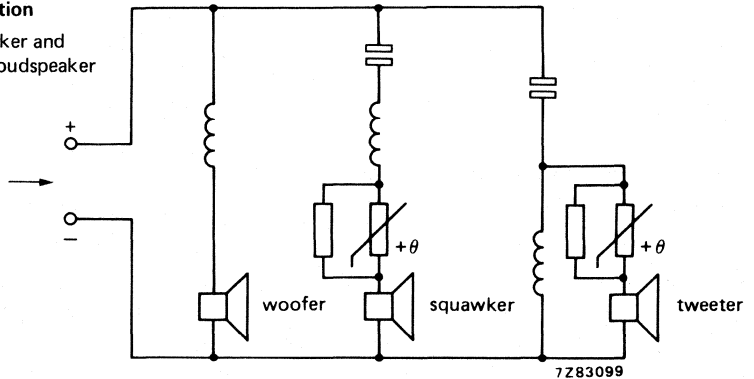

Heating

As e.g. used in hair curling tongs, heating plates.

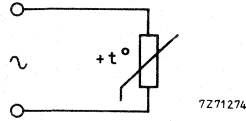

Ceramic elements with a positive temperature coefficient are particularly suitable for heating elements:

- they are self-regulating, so don't need thermostats to limit or stabilize temperature,
- they warm-up fast,
- the dissipated power is virtually independent of supply voltage.

The behaviour of PTC heating elements cannot easily be concluded from the R/T or V/I curves, because the temperature of the element is not homogenous during operation. In addition, the mounting has considerable influence on this behaviour which includes the dissipated power, the relevant temperature and the extent of the power regulation.

The uneven temperature profile across an element is due to the increased cooling of the faces of the element. This means that the inner temperature is usually higher than T_s whereas the upper and bottom temperature is lower than T_s .

Fig. 1 shows a typical temperature profile across a heating element.

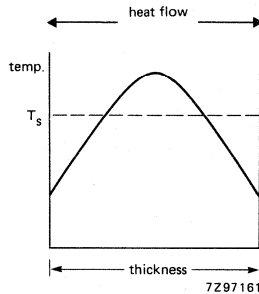

Fig. 1.

The inner part of the element is high-ohmic and there the dissipation is taking place. Consequently, heat transfer is from the inside to the faces of the element.

It is possible to make a thermal equivalent circuit of a PTC heating system. Such a circuit can be considered, also for calculations, as an electric simulator, so that an analysis of the system can be realized. Table 1 shows the analogy between electrical and thermal parameters. Fig. 2 shows a simplified thermal equivalent circuit.

PTC THERMISTORS

Table 1

	electrical	thermal
resistance	R (Ω)	R_{th} (K/W)
voltage	V (V)	T ($^{\circ}\text{C}$)
current	I (A)	P (W)
capacitance	C (F)	H (J/K)
Ω s law	$R = \frac{V}{I}$ $V = \frac{1}{C} \int Idt$	$R_{th} = \frac{T}{P}$ $T = \frac{1}{H} \int Pdt$

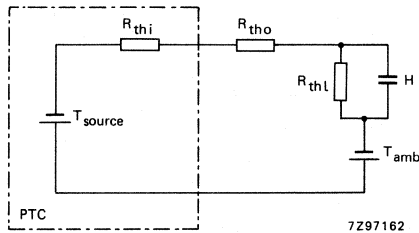

Fig. 2 Thermal equivalent circuit.

Using this thermal equivalent circuit, you can:

- do simple calculations on the heating system (because of the resemblance with electrical circuits)
- acquire a good insight in the operation of a PTC heater
- predict the influence of different parameters.

The power in stabilized conditions can be calculated from:

$$P = \frac{T_{source} - T_{amb}}{R_{thi} + R_{tho} + R_{thl}} \quad (\text{W})$$

The temperature of the object is:

$$T_l = \frac{R_{thl}}{R_{thi} + R_{tho} + R_{thl}} \times [T_{source} - T_{amb}] + T_{amb} \quad (^{\circ}\text{C})$$

The time constant of the system is:

$$\tau = H \times \frac{R_{thl} \times (R_{thi} + R_{tho})}{R_{thl} + R_{thi} + R_{tho}} \quad (s)$$

- T_{source} (°C) is mainly determined by T_s . The value is approx. $T_s + 25$
- T_{amb} (°C) is ambient temperature
- R_{thi} is the internal thermal resistance of the PTC. This value is mainly determined by:
 - a) dimensions of the ceramic
 - b) thermal conductivity of the ceramic ($\lambda = 2,4 \text{ W/mK}$)
- R_{tho} is the thermal resistance between the surface of the ceramic and the object to be heated and is computed from various parameters:
 - a) thermal resistance between ceramic and isolator
 - b) thermal resistance of the isolator
 - c) thermal resistance between isolator and object to be heated
- R_{thl} is the thermal resistance of the object to be heated
- H is the thermal capacity of the object

For optimum heating performance, the R_{tho} must be kept as low as possible.

For the insulated heating element range 2322 680 0 the total thermal resistance ($R_{thi} + R_{tho}$) is approximately 2,5 K/W, when properly mounted.

Temperature/power curve

Another presentation, derived from the thermal equivalent circuit is a graphical one, see Fig. 3.

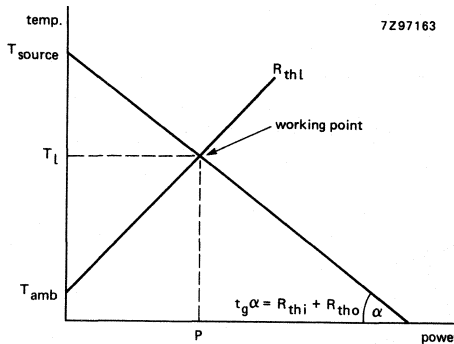

Fig. 3.

Influence of ambient temperature, load and mounting on heating performance

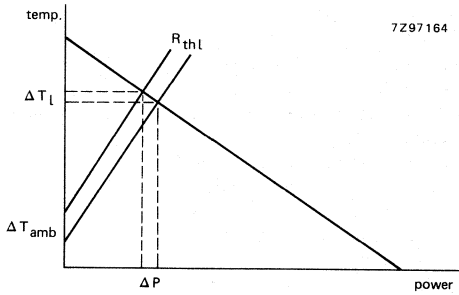

Fig. 4 Influence of ambient temperature.

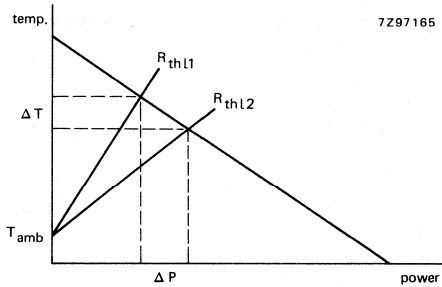

Fig. 5 Influence of load variation.

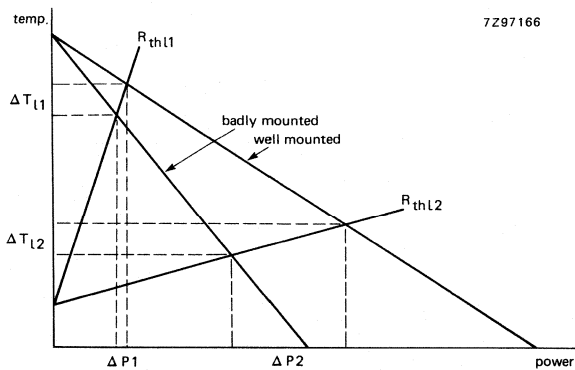

Fig. 6 Influence of mounting method.

The temperature power curve must be as flat as possible for the best temperature stabilization properties (R_{th0} as low as possible).

When a heating element such as 2322 680 04022 is mounted in an aperture which is too large, the thermal coupling will be poor. This results in a high value is R_{th0} .

When a heating element is not heavily loaded, e.g. in a hair curler (represented by R_{th11}) the influence of poor mounting is not so severe as for a system in which the heating element is heavily loaded, e.g. in a pre-heating system for an oil burner (represented by R_{th12}).

Example

Heating plate using PTC 2322 680 04022.

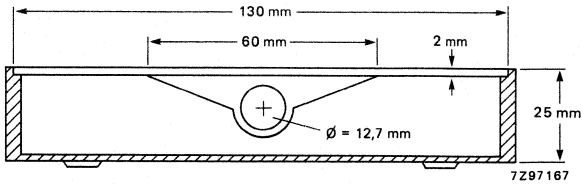

Fig. 7.

The aluminium plate is 130 x 130 x 2 mm. The results are depicted in Fig. 8.

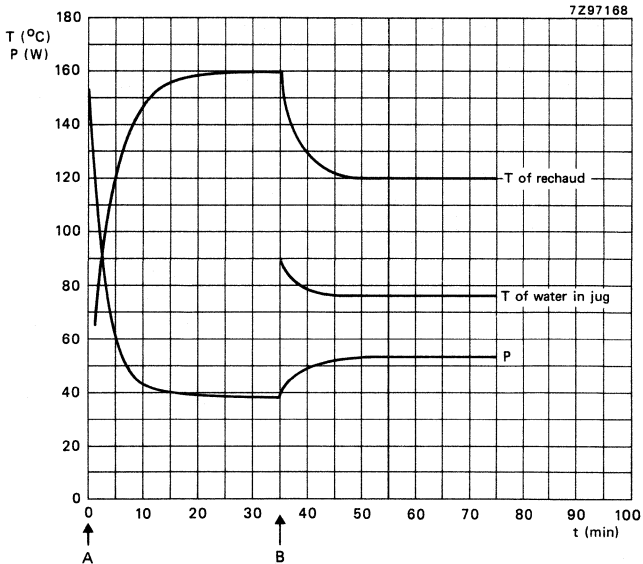

Fig. 8 A = heating plate switched on, unloaded; B = loaded with pyrex water jug containing 1 liter, 90 °C; ambient air temperature = 20 °C (constant).

PTC THERMISTOR

disc

QUICK REFERENCE DATA

Resistance value at +25 °C	250 Ω \pm 25%
Resistance value at +80 °C	3700 Ω \pm 30%
Switch temperature	+6 °C approx.
Temperature coefficient	+5%/K approx.
Max. voltage at $T_{amb} = +55$ °C	25 V d.c.
Dissipation factor	6 mW/K approx.
Operating temperature range at zero power	-25 to +155 °C
at V_{max}	0 to +55 °C

APPLICATION

Temperature compensating and temperature measurement purposes.

DESCRIPTION

The thermistor has a positive temperature coefficient. It consists of a disc with two tinned copper wires. The thermistor body is blue lacquered but not insulated.

MECHANICAL DATA

Outlines

Mass 0,3 g approximately

Mounting In any position by soldering

Robustness of terminations

Tensile strength 10 N

Bending 5 N

Soldering

Solderability max. 240 °C, max. 4 s

Resistance to heat max. 265 °C, max. 11 s

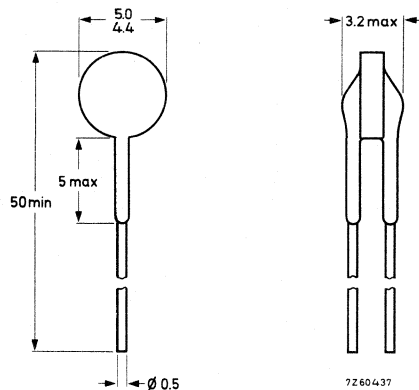

Fig. 1.

ELECTRICAL DATA

Resistance *	
at +25 °C (T_{ref})	250 Ω \pm 25%
at +80 °C	3700 Ω \pm 30%
Switch temperature	\sim +6 °C
Temperature coefficient	\sim +5%/K
Dissipation factor **	\sim 6 mW/K
Heat capacity **	\sim 0,1 J/K
Thermal time constant **	\sim 17 s
Operating temperature range	
at zero power	-25 to +155 °C
at V_{max}	0 to +55 °C
Voltage dependence at +155 °C	0,25 approx.
Balance voltage (d.c.)	13 V approx.
Maximum voltage (d.c.)	25 V

PACKAGING

500 thermistors in a cardboard box.

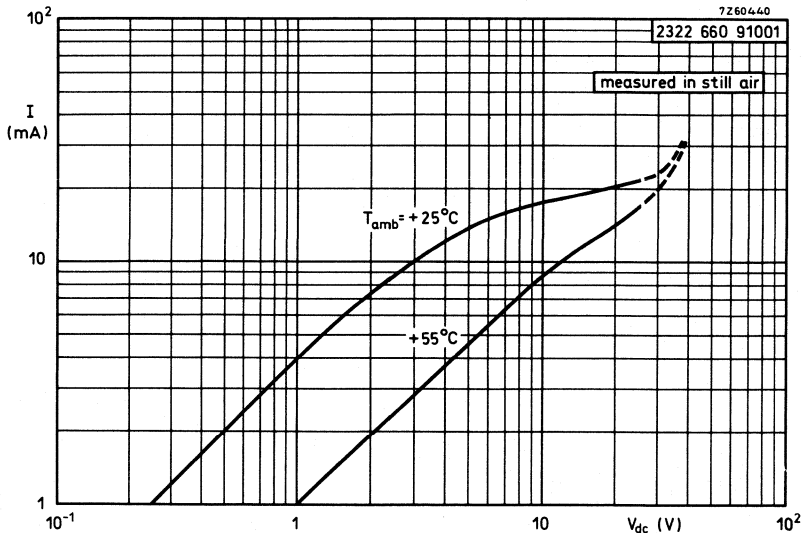

Fig. 2 Typical current/voltage characteristics.

* Measuring voltage not exceeding 1,5 V(d.c.) to avoid internal heating.
 ** Measurement made with specimen in phosphor bronze clips in still air.

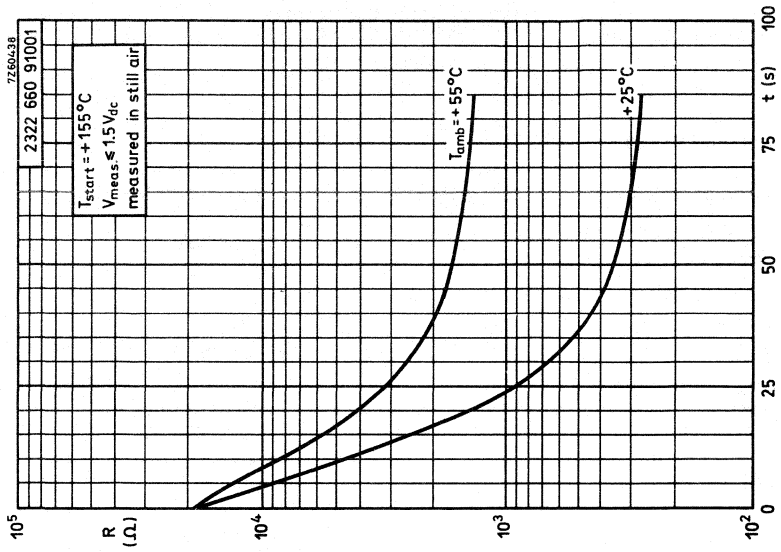

Fig. 4 Typical resistance/time (cooling) characteristics.

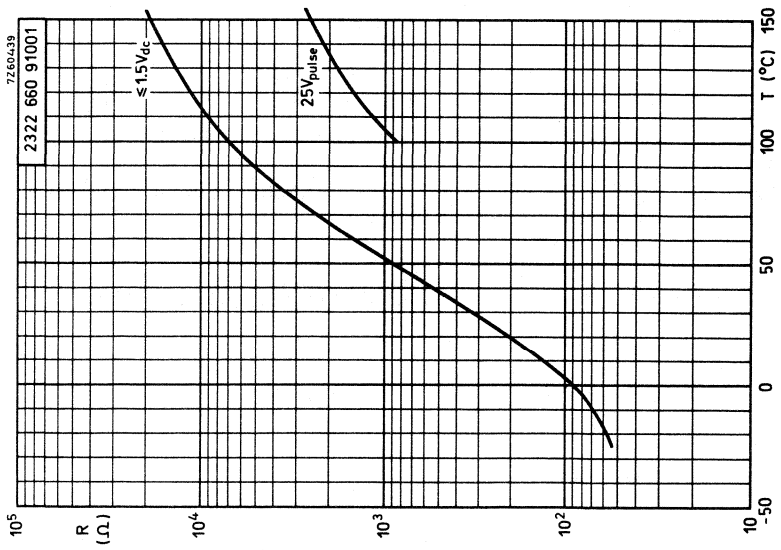

Fig. 3 Typical resistance/temperature characteristics.

PTC THERMISTORS

disc

QUICK REFERENCE DATA

Resistance values at +25 °C	50 and 60 $\Omega \pm 30\%$
Resistance at other temperatures	} see table
Switch temperature	
Temperature coefficient	} see table
Max. voltage (d.c.)	
Dissipation factor	~ 7 mW/K
Operating temperature range	-10 to +125 °C *
at zero power	
at V_{max}	

MECHANICAL DATA

Outlines

catalogue number	colour band
2322 660 91006	red
2322 660 91007	orange
2322 660 91008	yellow
2322 660 91009	green

APPLICATION

General purpose.

DESCRIPTION

The thermistors have a positive temperature coefficient. They consist of a disc with two tinned copper wires. The thermistor body is blue lacquered but not insulated.

Marking

The thermistors are marked with a colour band at the top of the body according to Fig. 1.

Mass 0,4 g approximately

Mounting In any position by soldering

PACKAGING

500 thermistors in a cardboard box.

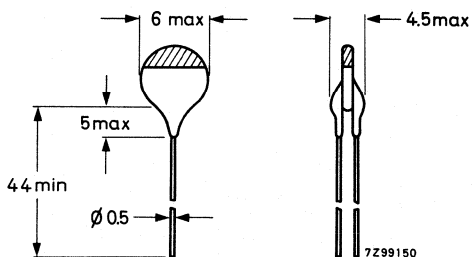

Fig. 1.

* Type 2322 660 91009: -10 to +150 °C.

ELECTRICAL DATA

	catalogue number 2322 660 followed by				
	91006	91007	91008	91009	
Resistance * at 25 °C	60	50	50	50	Ω
at 125 °C	3 to 15	100 to 500	50 to 500		k Ω
at 150 °C				0,1 to 1,2	M Ω
Switch temperature	30	50	80	105	°C
R_{max} at T_s	100	300	400	400	Ω
Temperature coefficient	7	16	23	40	%/K
Heat capacity **	0,13	0,13	0,13		J/K
Thermal time constant **	20	18	18		s
Voltage dependence β	0,19	0,17	0,18		
Balance voltage (d.c.)	35	12,5	23		V

Tolerance on R_{25} $\pm 30\%$
 Max. voltage (d.c.) 25 V
 Dissipation factor ~ 7 mW/K
 Operating temperature range
 at zero power -10 to $+125$ °C ***
 at V_{max} 0 to $+55$ °C

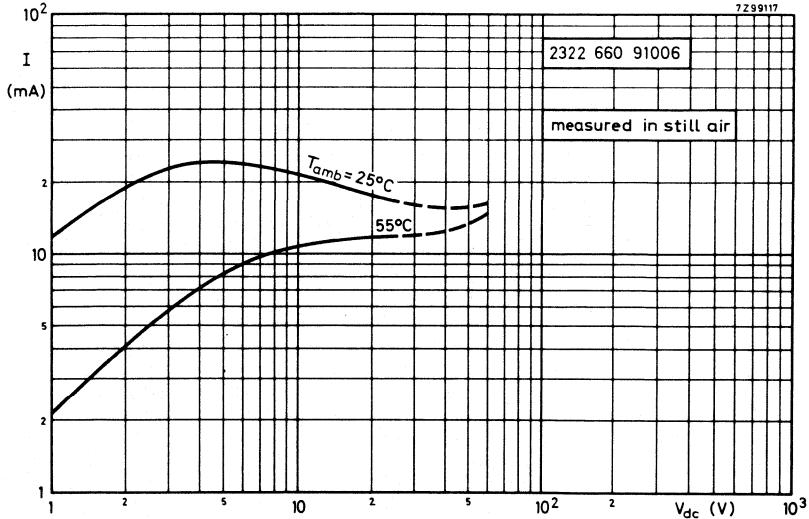

Fig. 2 Typical voltage/current characteristics.

* Measuring voltage not exceeding 1,5 V(d.c.) to avoid internal heating.
 ** Measurements made with specimen in phosphor bronze clips, in still air.
 *** Type 2322 660 91009: -10 to $+150$ °C.

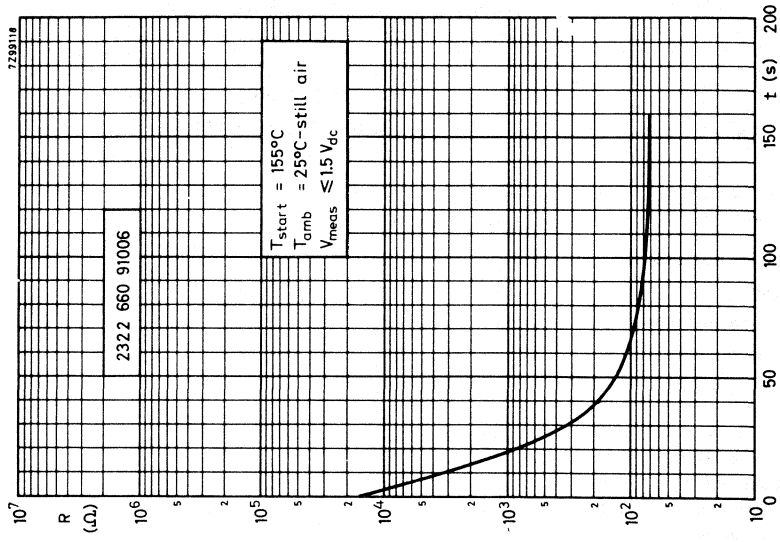

Fig. 4 Typical resistance/time (cooling) characteristic.

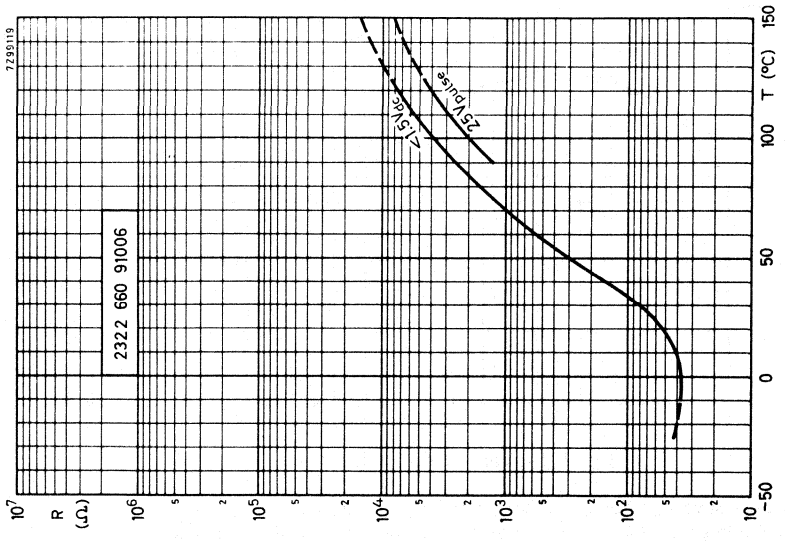

Fig. 3 Typical resistance/temperature characteristics.

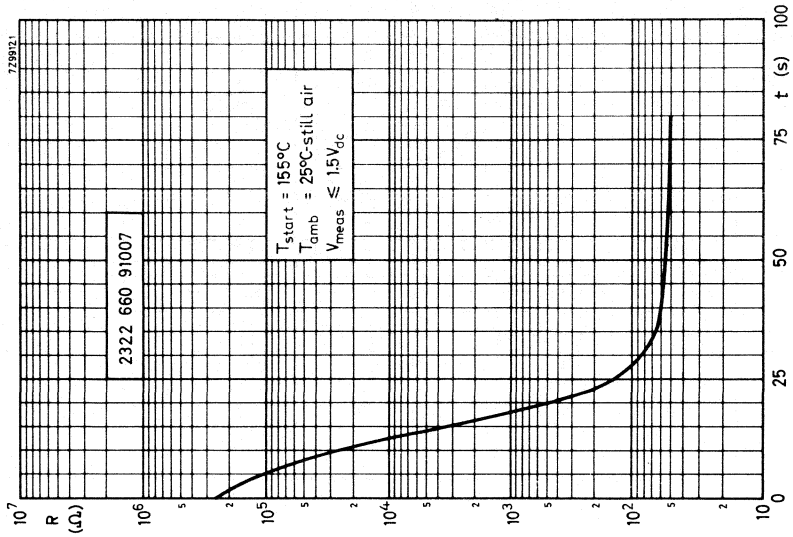

Fig. 6 Typical resistance/time (cooling) characteristic.

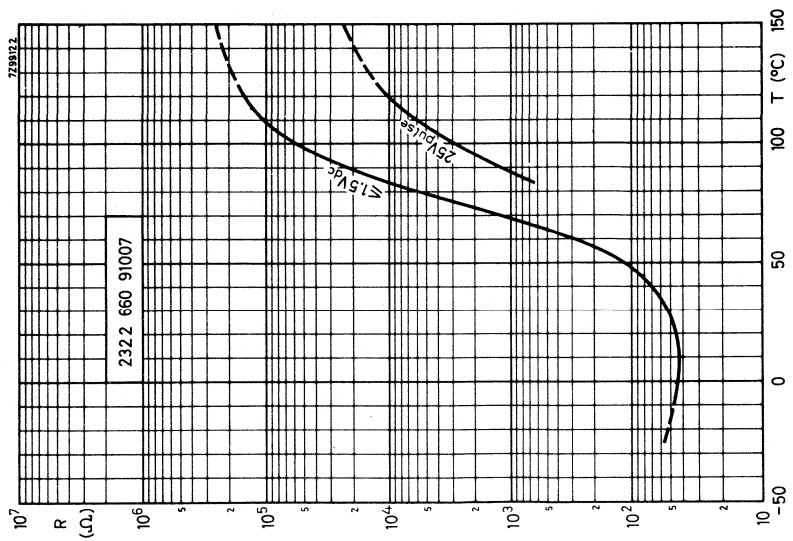

Fig. 5 Typical resistance/temperature characteristics.

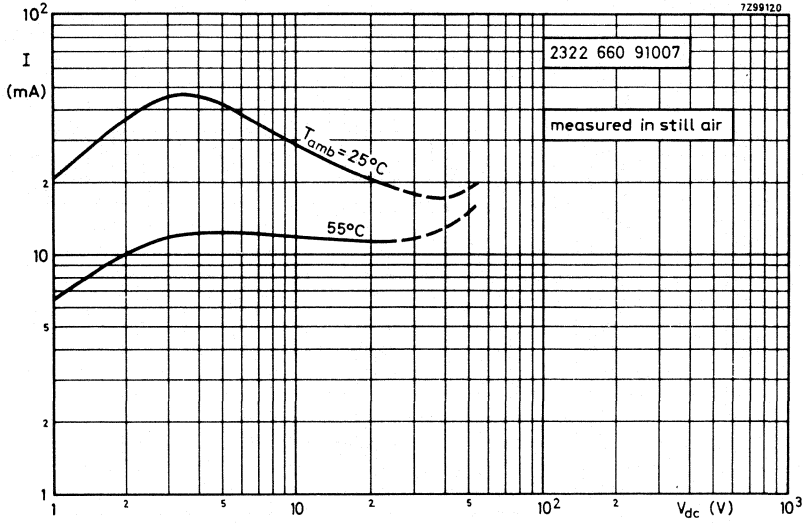

Fig. 7 Typical voltage/current characteristics.

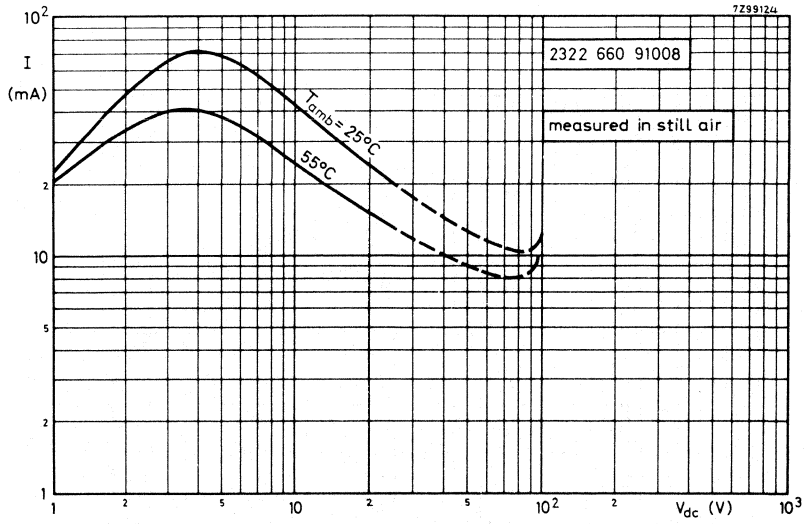

Fig. 8 Typical voltage/current characteristics.

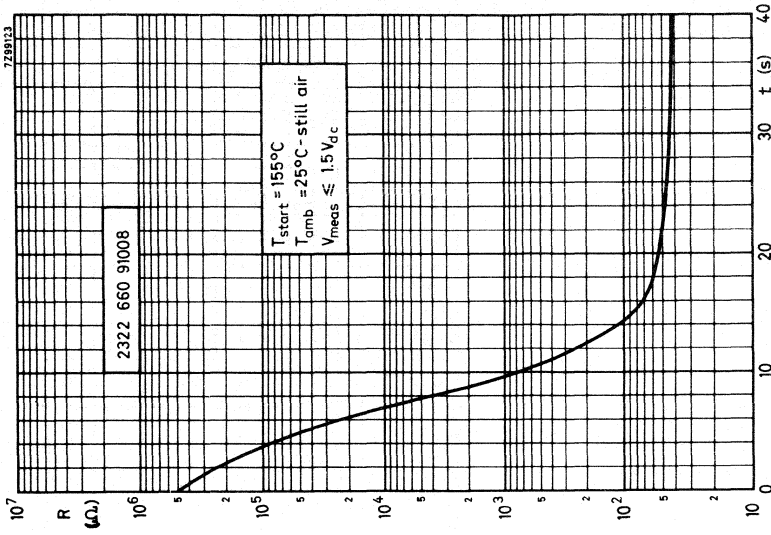

Fig. 10 Typical resistance/time (cooling) characteristic.

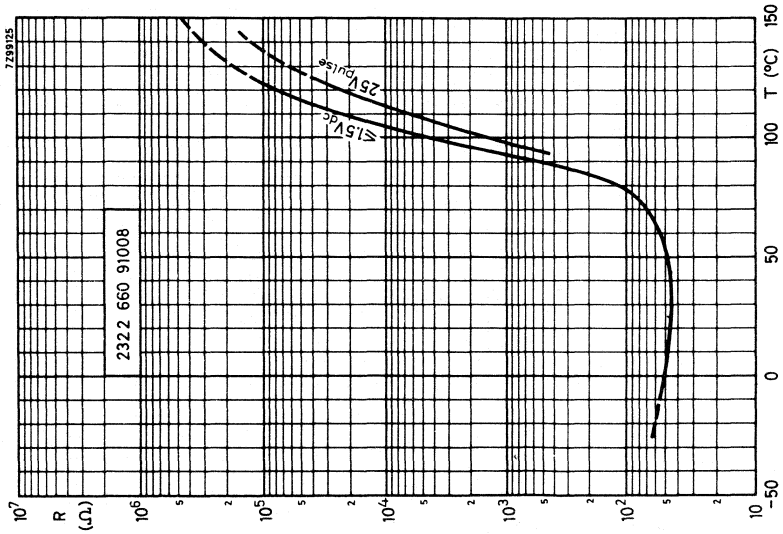

Fig. 9 Typical resistance/temperature characteristics.

Fig. 11 Typical resistance/
temperature characteristic.

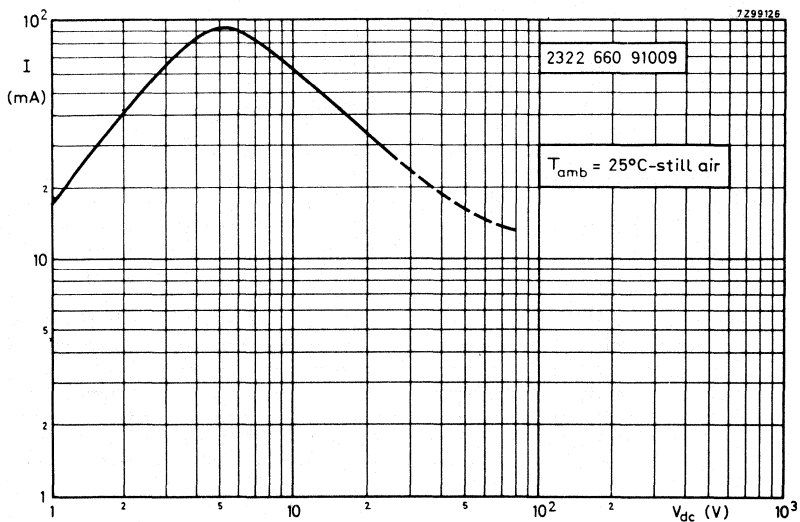
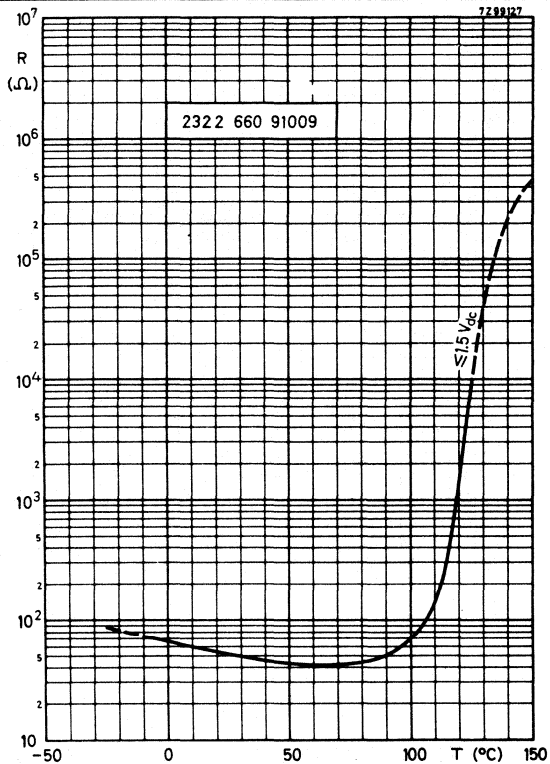

Fig. 12 Typical voltage/current characteristic.

PTC THERMISTOR

disc

QUICK REFERENCE DATA

Resistance value at +25 °C	750 to 1500 Ω
Resistance value at +175 °C V _{pulse} = 345 V	70 000 Ω
Switch temperature	+115 °C
Temperature coefficient	+26%/K
Maximum voltage (r.m.s.)	245 V
Dissipation factor	7 mW/K
Operating temperature range at zero power	-25 to +155 °C
at maximum voltage	0 to +55 °C

APPLICATION

General purpose.

DESCRIPTION

The thermistor has a positive temperature coefficient. It consists of a disc with two tinned copper wires. The thermistor body is blue lacquered but not insulated.

MECHANICAL DATA

Outlines

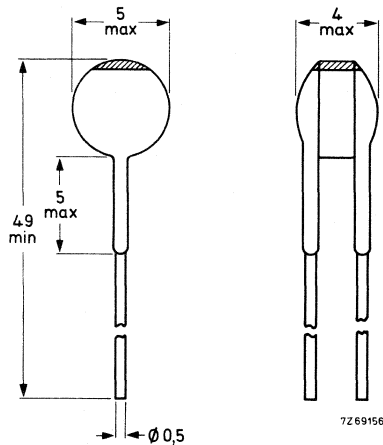

PACKAGING

500 thermistors in a cardboard box.

Marking	Brown band on top, see Fig. 1.
Mass	0,4 g approximately
Mounting	In any position by soldering
Robustness of terminations	
Tensile strength	5 N
Bending	2,5 N
Soldering	
Solderability	max. 240 °C, max. 4 s
Resistance to heat	max. 265 °C, max. 11 s
Impact	1000 mm free fall
Inflammability	Uninflammable

ELECTRICAL DATA

Unless otherwise specified measured according to IEC draft publication 40 (secretariat) 288.
All values in the table without further indication are approximate values.

Resistance at +25 °C	750 to 1500 Ω
Resistance at +115 °C	max. 4000 Ω
Resistance at +175 °C and $V_{\text{pulse}} = 345 \text{ V}$	min. 70 000 Ω
Switch temperature	+115 °C
Temperature coefficient	+28%/K
Dissipation factor	7 mW/K
Heat capacity of ceramic only	0,125 J/K 0,08 J/K
Thermal time constant	17,5 s
Operating temperature range at zero power at maximum voltage	-25 to +155 °C 0 to +55 °C
Voltage dependence at +155 °C	0,35
Balance voltage d.c.	90 V
Maximum voltage (r.m.s.)	245 V

* Measurement made without internal heating occurring.

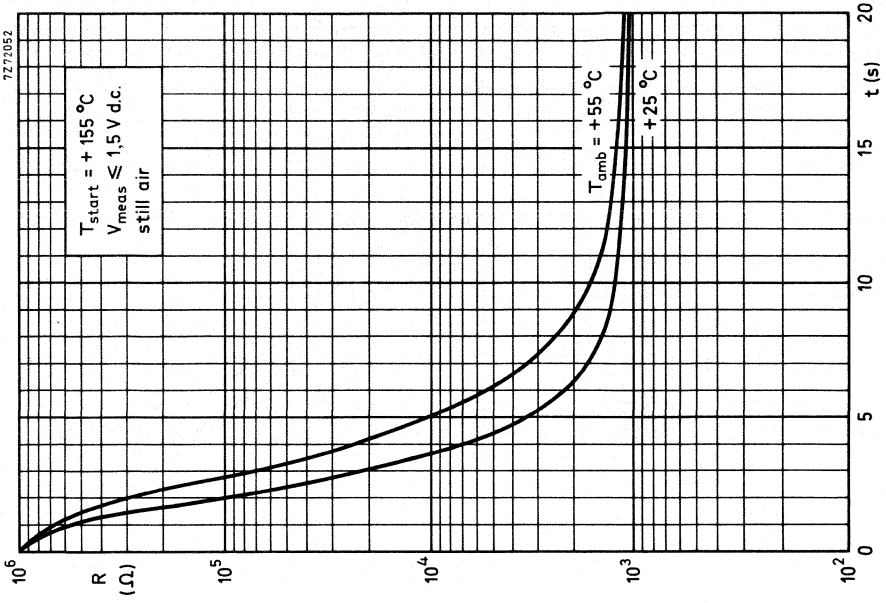

Fig. 3 Typical resistance/time (cooling) characteristics.

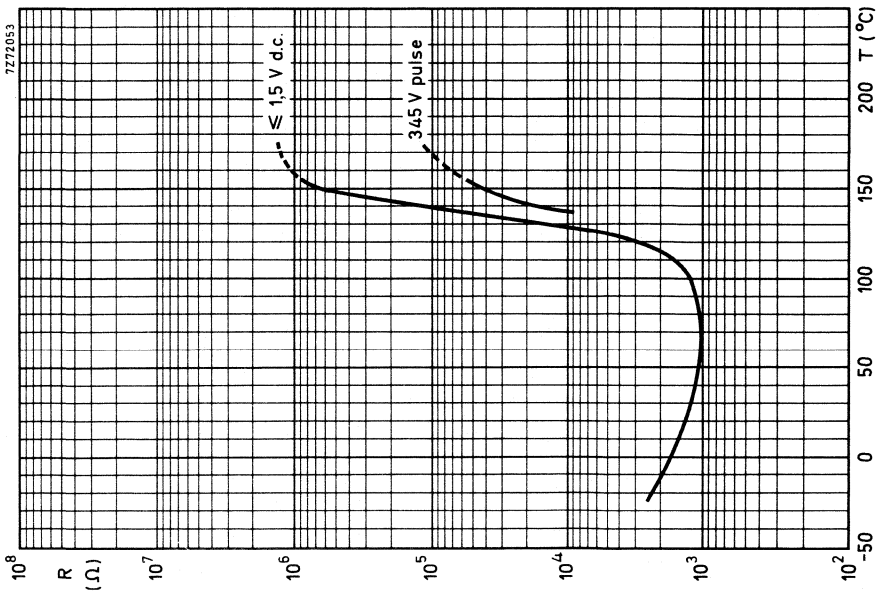

Fig. 2 Typical resistance/temperature characteristics.

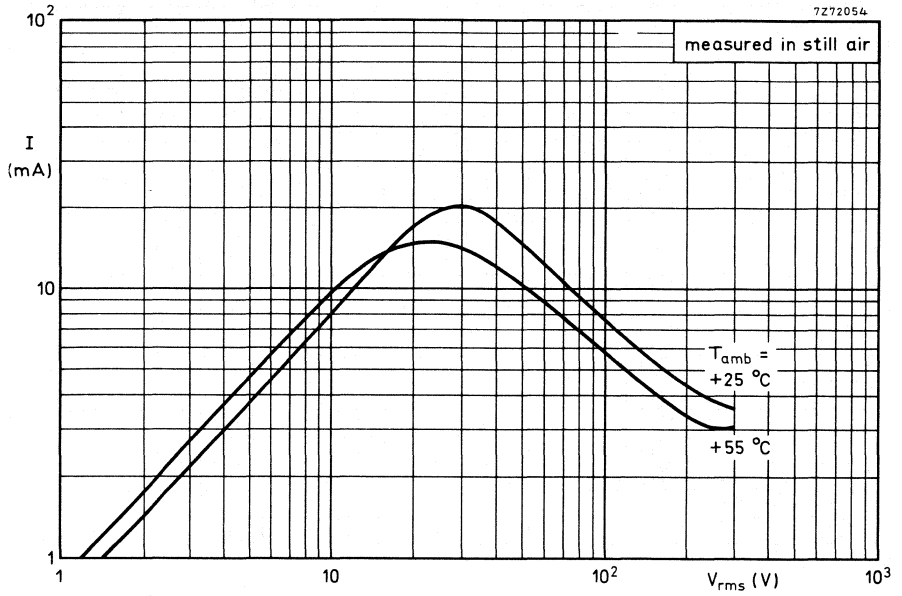

Fig. 4 Typical voltage/current characteristics.

PTC THERMISTORS

disc

QUICK REFERENCE DATA

Resistance value at +25 °C	30 to 50 Ω
Operating temperature range at zero power at V_{max}	-10 to +125 °C 0 to +55 °C

APPLICATION

General purpose.

DESCRIPTION

The thermistors have a positive temperature coefficient. They consist of a disc with two tinned copper wires. The thermistor body is blue lacquered but not insulated.

MECHANICAL DATA

Outlines

Table 1

catalogue number	colour band	H_{max}
2322 661 91002	yellow	6
2322 661 91003	green	6
2322 661 91004	orange	6
2322 661 91005	red	5

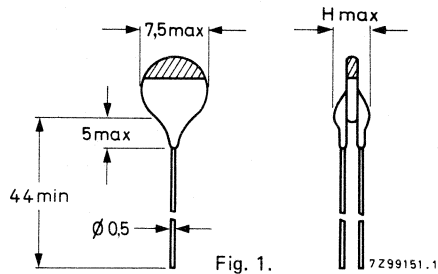

Marking

The thermistors are marked with a colour band at the top of the body according to Fig. 1.

Mass 1 g approximately

Mounting In any position by soldering

Robustness of terminations

Tensile strength 10 N
Bending 5 N

Soldering

Solderability max. 240 °C, 4 s
Resistance to heat max. 240 °C, 4 s

PACKAGING

500 thermistors in a cardboard box.

ELECTRICAL DATA

Table 2, typical values except R and V_{max}

	catalogue number 2322 661 followed by				
	91002	91003	91004	91005	
Resistance					
at 25 °C *	50	40	30	50	Ω
at 40 °C			< 90		Ω
at 60 °C	< 100				Ω
at 95 °C		< 80			Ω
at 100 °C	> 1		> 10	3 to 20	k Ω
at 130 °C		> 10			k Ω
Dissipation factor ***	8,5	8,5	8,5	6	mW/K
Maximum voltage (d.c.)	50	50	50	40	V
Switch temperature	80	110	45	25	°C
Temperature coefficient	18	75	16	9	%/K
Heat capacity ***	0,425	0,425	0,425	0,240	J/K
Thermal time constant ***	50	50	50	40	s
Voltage dependence β	0,48	0,28	0,25	0,35	
Balance voltage (d.c.)	110	25	65	25	V
Tolerance on R ₂₅	$\pm 15 \Omega$				
Operating temperature range					
at zero power	-10 to +125 °C				
at V_{max}	0 to +55 °C				

* Measuring voltage not exceeding 1,5 V (d.c.) to avoid internal heating.

** Measured without internal heating.

*** Measured with phosphor-bronze clips, in still air.

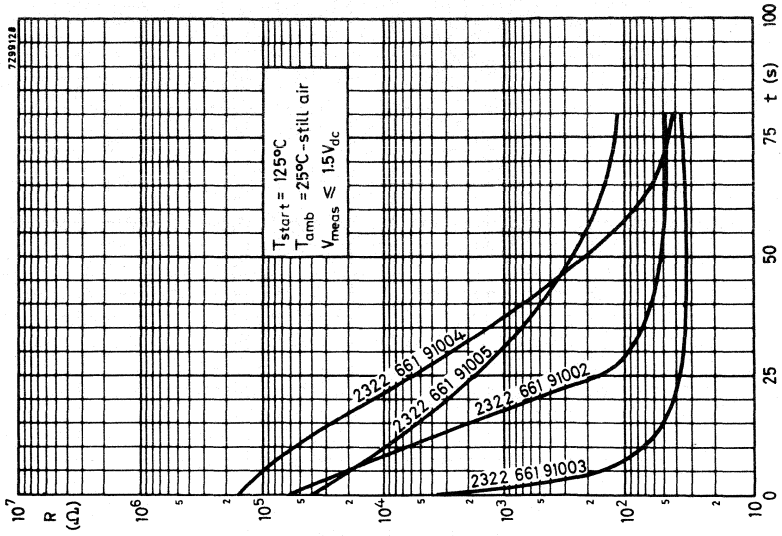

Fig. 3 Typical resistance/time (cooling) characteristics.

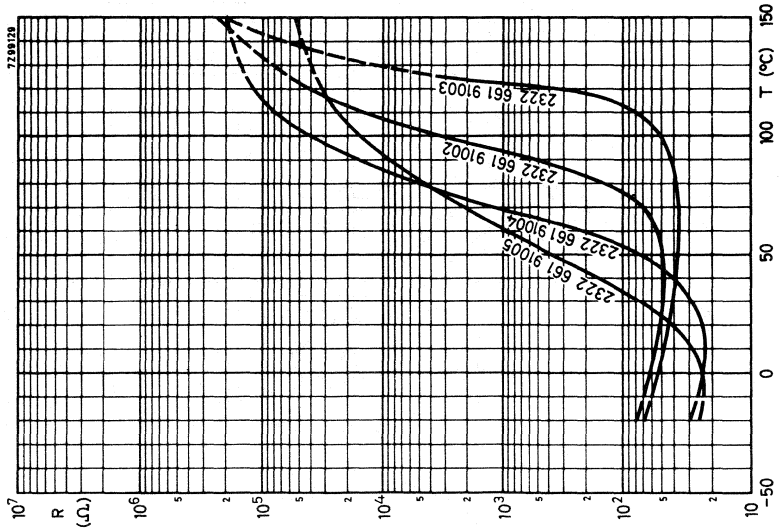

Fig. 2 Typical resistance/temperature characteristics.

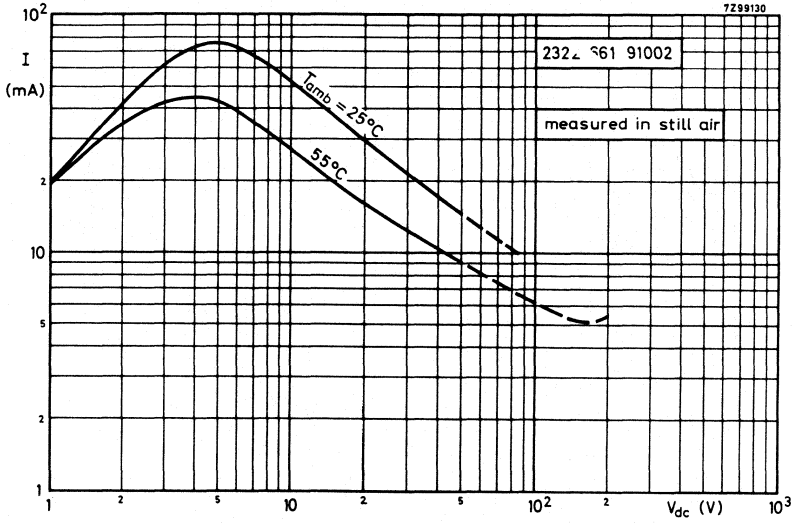

Fig. 4 Voltage/current characteristics.

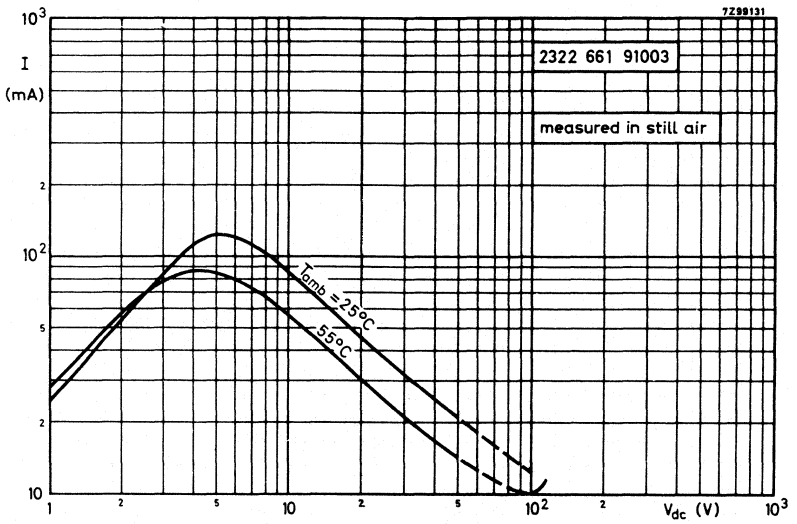

Fig. 5 Voltage/current characteristics.

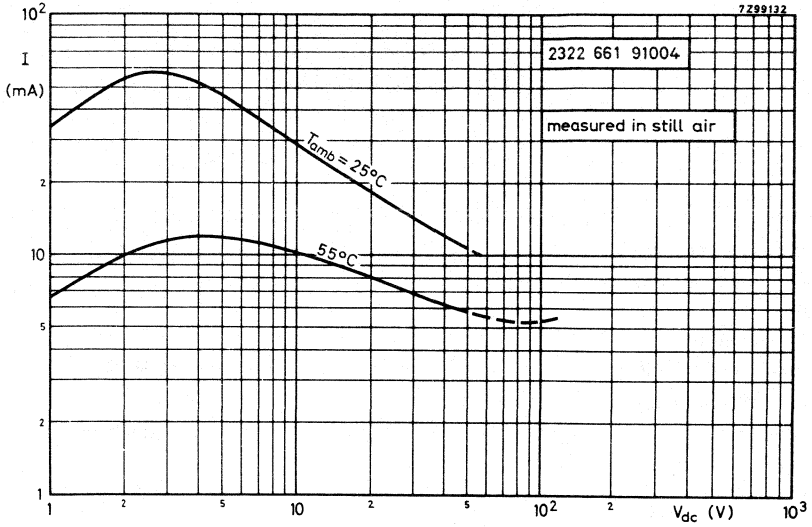

Fig. 6 Voltage/current characteristics.

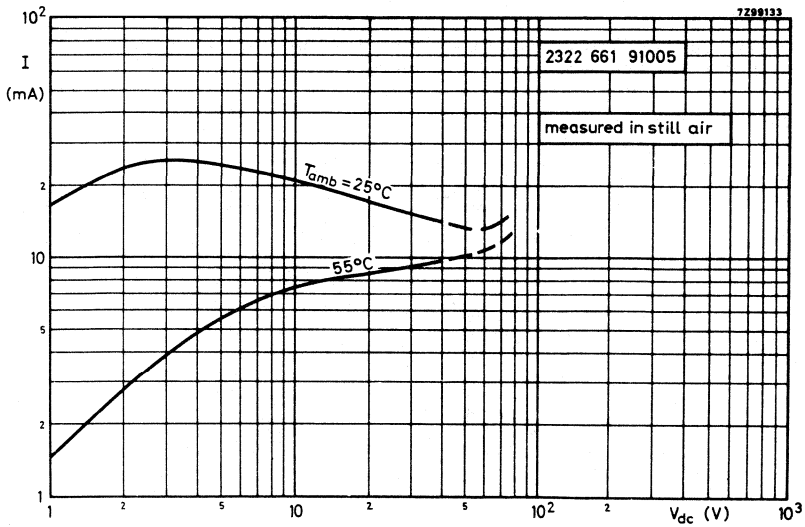

Fig. 7 Voltage/current characteristics.

PTC THERMISTOR

disc

QUICK REFERENCE DATA

Resistance value at +25 °C	36 to 50 Ω
Resistance value at +165 °C V _{pulse} = 180 V	> 20 kΩ
Switch temperature	~ +115 °C
Temperature coefficient	~ 35%/K
Maximum voltage (d.c.)	180 V
Dissipation factor	~ 13 mW/K
Operating temperature range at zero power	0 to +155 °C
at maximum voltage (d.c.)	0 to +55 °C

APPLICATION

Protection of telegraphy relay contacts.

DESCRIPTION

The thermistor has a positive temperature coefficient. It consists of a disc with two tinned brass wires. The thermistor body is blue lacquered but not insulated.

MECHANICAL DATA

Outlines

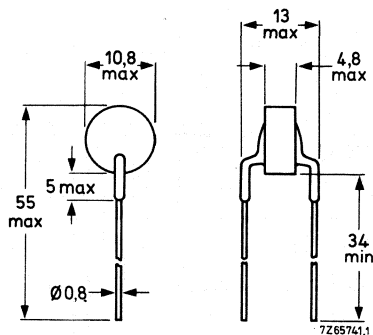

Fig. 1.

Mass	0,5 g approximately
Mounting	In any position by soldering

PACKAGING

100 thermistors in a cardboard box.

ELECTRICAL DATA

Resistance	
at +25 °C (T_{ref})*	36 to 50 Ω
at +115 °C**	< 120 Ω
at +165 °C, $V_{pulse} = 180$ V**	> 20 k Ω
Current at +25 °C, $V_{dc} = 180$ V continuously ***	< 10 mA
Switch temperature	~ +115 °C
Temperature coefficient	~ 35%/K
Dissipation factor ***	~ 13 mW/K
Heat capacity ***	1 J/K
Thermal time constant ***	~ 80 s
Operating temperature range	
at zero power	0 to +155 °C
at V_{max}	0 to +55 °C
Voltage dependence β at +150 °C	~ 0,3
Balance voltage (d.c.)	~ 105 V
Maximum voltage (d.c.) at +55 °C	180 V

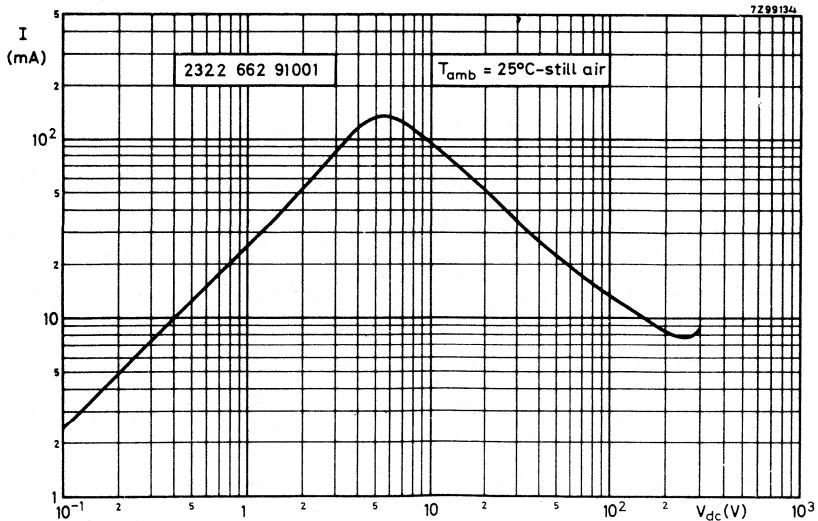

Fig. 2 Typical voltage/current characteristic.

- * Measuring voltage not exceeding 1,5 V(d.c.) to avoid internal heating.
- ** Measurement made without internal heating occurring.
- *** Measurement made with specimen in phosphor bronze clips, in still air.

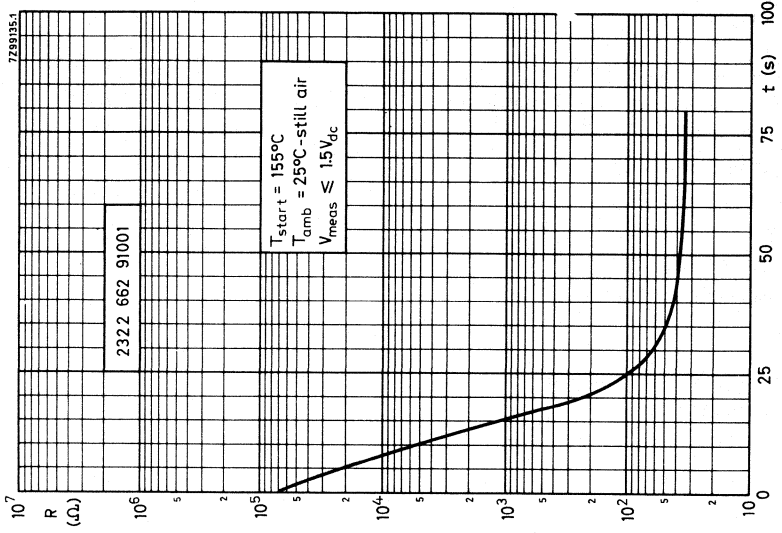

Fig. 4 Typical resistance/time (cooling) characteristic.

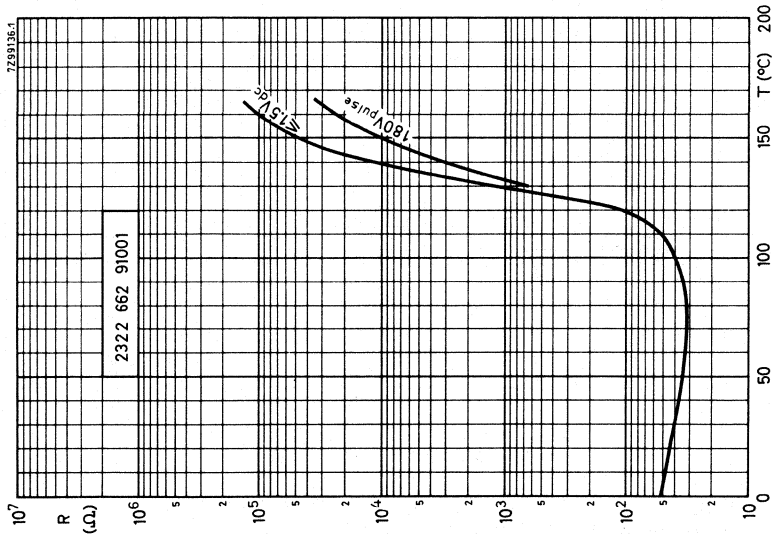

Fig. 3 Typical resistance/temperature characteristics.

PTC THERMISTOR

disc

QUICK REFERENCE DATA

Resistance value at +25 °C	max. 1,1 Ω
Resistance value at +55 °C	max. 1 Ω
Switch temperature	+100 °C
Temperature coefficient	+6%/K
Maximum r.m.s. voltage	18 V
Operating temperature range at zero power	-25 to +155 °C
at maximum voltage	0 to +55 °C

APPLICATION

Overload protection of loudspeakers.

DESCRIPTION

The thermistor has a positive temperature coefficient. It consists of a disc with two tinned brass wires.

MECHANICAL DATA

Outlines

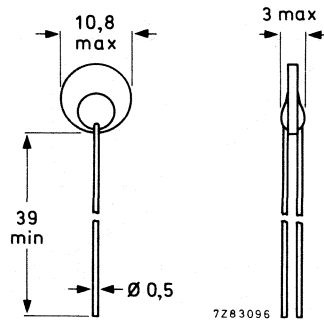

Fig. 1.

Marking

None

Mass

0,55 g approximately

Mounting

In any position by soldering

Soldering

Solderability

max. 240 °C, max. 4 s

Resistance to heat

max. 265 °C, max. 11 s

Impact

0,2 m free fall

Inflammability

Uninflammable

ELECTRICAL DATA

All values in the table without further indication are approximate values

Resistance at +25 °C	max. 1,1 Ω
Resistance at +115 °C	max. 1 Ω
Switch temperature	+100 °C
Switching current at $T_{amb} = +25 °C$	max. 710 mA
Max. current at which no switching occurs at $T_{amb} = +25 °C$	570 mA
Temperature coefficient	+6%/K
Maximum r.m.s. voltage	18 V
Response time at $I = 1,3 A$ and $T_{amb} = +25 °C$	max. 20 s
Steady state current at 18 V r.m.s. and $T_{amb} = +25 °C$	max. 95 mA
Operating temperature range at zero power	-25 to +155 °C
at maximum voltage	0 to +55 °C

PACKAGING

250 thermistors in a cardboard box.

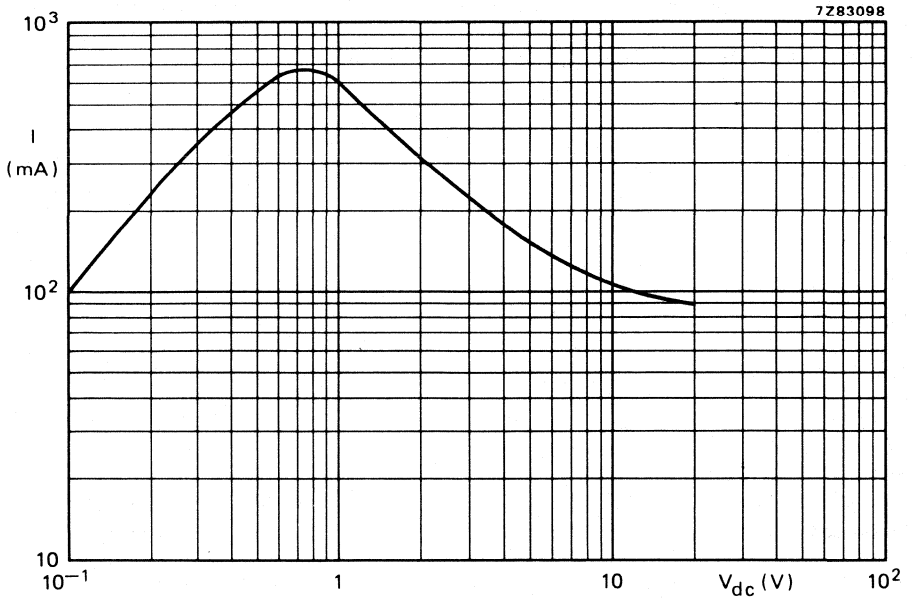

Fig. 2 Typical current/voltage characteristic.

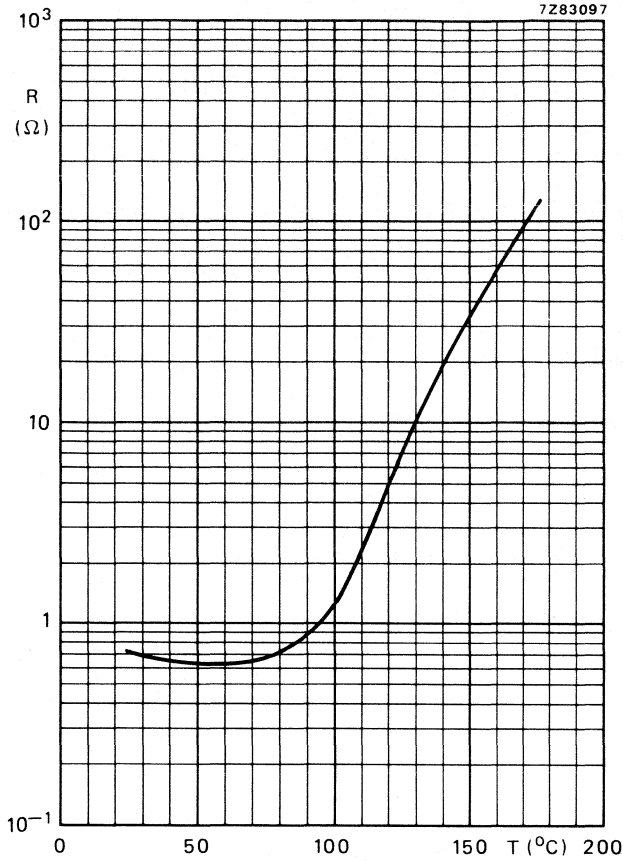

Fig. 3 Typical resistance/temperature characteristic.

PTC THERMISTOR

disc

QUICK REFERENCE DATA

Resistance value at +25 °C	70 to 100 Ω
Max. current at 600 V r.m.s. and +25 °C	5 mA
Switch temperature	+120 °C
Temperature coefficient	+35%/K
Maximum r.m.s. voltage	460 V
Dissipation factor	11,5 mW/K
Operating temperature range at zero power	-25 to +175 °C
at maximum voltage	0 to +85 °C

APPLICATION

Suitable in all kinds of applications, e.g. fluorescent lamp starter.

DESCRIPTION

This thermistor has a positive temperature coefficient. It is a leadless disc which is neither lacquered nor insulated.

MECHANICAL DATA

Outlines

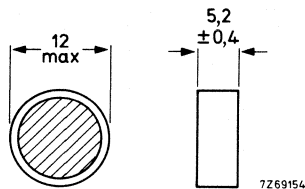

Fig.1.

Marking

None

Mass

2,7 g approximately

Mounting

In any position by clamping

Impact

100 mm free fall

Inflammability

Uninflammable

PACKAGING

Plastic blister pack containing 192 items.

ELECTRICAL DATA

All values in this table without further indication are approximate values.

Resistance at +25 °C	70 to 100 Ω
Resistance at +100 °C	max. 200 Ω
Max. current at 600 V r.m.s. and +25 °C (measurement made without internal heating)	5 mA
Switch temperature	+120 °C
Temperature coefficient	+35%/K
Dissipation factor	11,5 mW/K
Heat capacity	1,3 J/K
Thermal time constant	115 s
Operating temperature range	
at zero power	-25 to +175 °C
at maximum voltage	0 to +85 °C
Voltage dependence at +175 °C	0,22
Balance voltage	230 V
Maximum r.m.s. voltage, with series resistor of 300 Ω	460 V

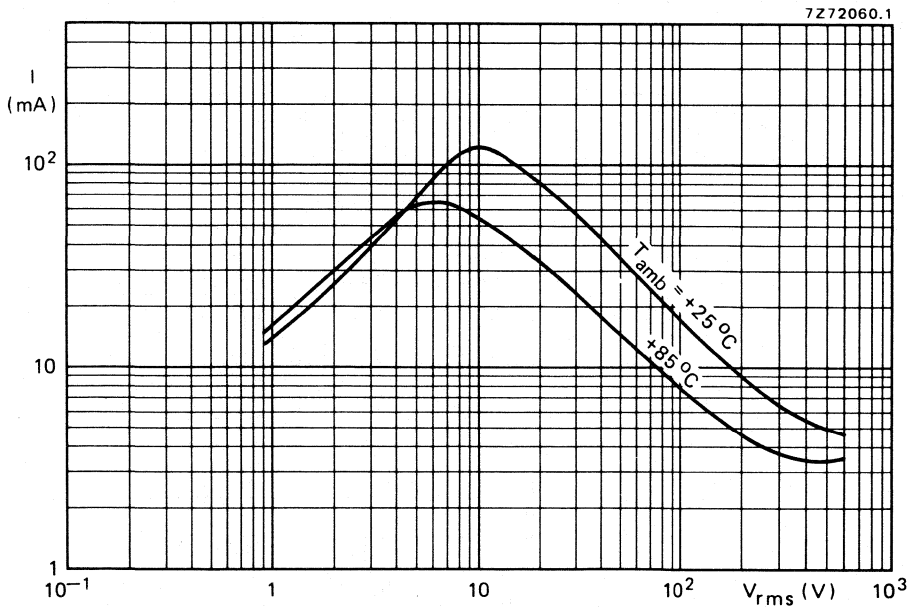

Fig. 2 Typical voltage/current characteristics.

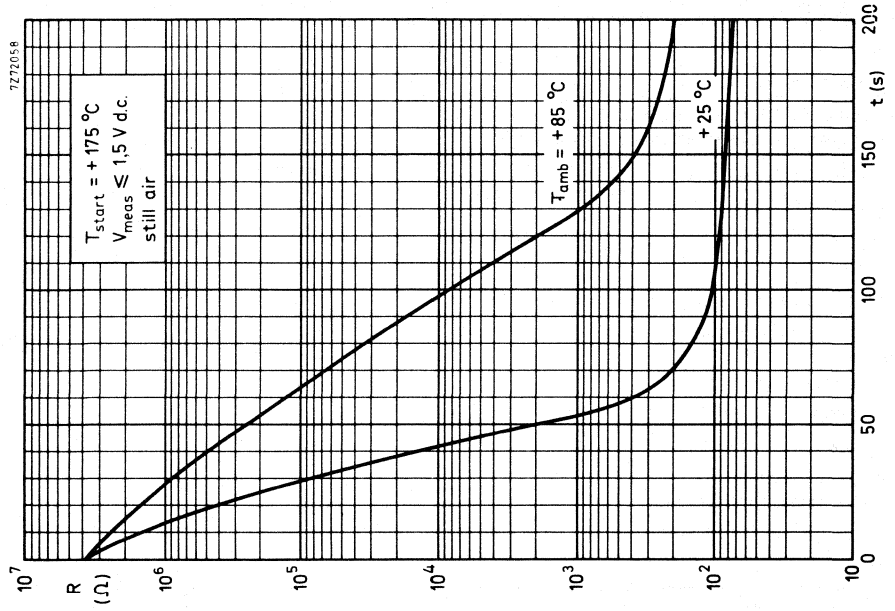

Fig. 3 Typical resistance/time (cooling) characteristics.

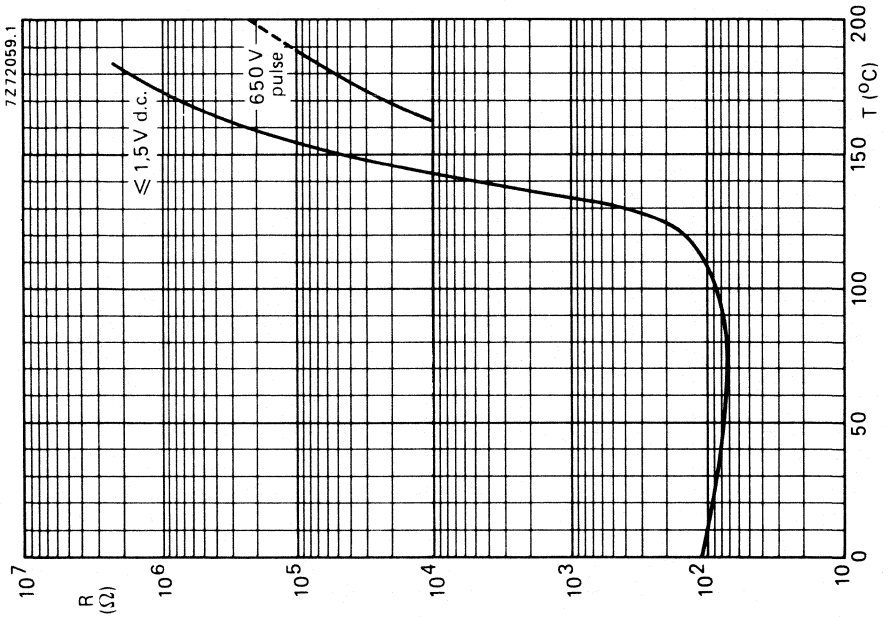

Fig. 2 Typical resistance/temperature characteristics.

PTC THERMISTOR

disc

QUICK REFERENCE DATA

Resistance value	
at +25 °C	45 to 60 Ω
at +150 °C	> 45 kΩ
V _{pulse} = 340 V	
Switch temperature	~ +75 °C
Temperature coefficient	~ +20%/K
Max. r.m.s. voltage at T _{amb} ≤ 60 °C	265 V
Dissipation factor	~ 20 mW/K
Operating temperature range	
at zero power	-25 to +155 °C
at V _{max}	0 to +60 °C

APPLICATION

In degaussing circuits of colour television sets.

DESCRIPTION

This thermistor has a positive temperature coefficient. It is a disc with two tinned copper wires. The thermistor body is blue lacquered, but not insulated.

MECHANICAL DATA

Outlines

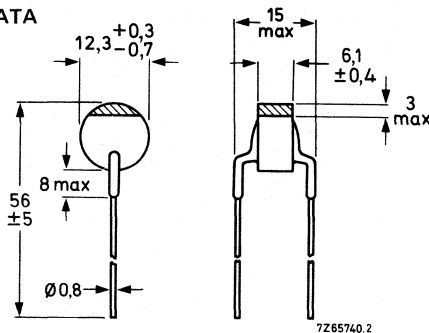

Fig. 1.

Marking	Green colour band on top of the body.
Mass	4,2 g approximately.
Mounting	In any position by soldering. Soldering should be done at least 15 mm from the thermistor body.

PACKAGING

100 thermistors in a cardboard box.

ELECTRICAL DATA

Resistance		
at +25 °C *		45 to 60 Ω
at +75 °C *		< 160 Ω
at +150 °C, $V_{pulse} = 340 V$ **		> 45 kΩ
Switch temperature	~	+75 °C
Temperature coefficient	~	+20%/K
Dissipation factor ***	~	20 mW/K
Heat capacity ***	~	2,2 J/K
Thermal time constant ***	~	110 s
Operating temperature range		
at zero power		-25 to +155 °C
at V_{max}		0 to +60 °C
Voltage dependence β at +155 °C	~	0,29
Balance voltage (d.c.)	~	200 V
Maximum r.m.s. voltage, with series resistor of 33 Ω		265 V

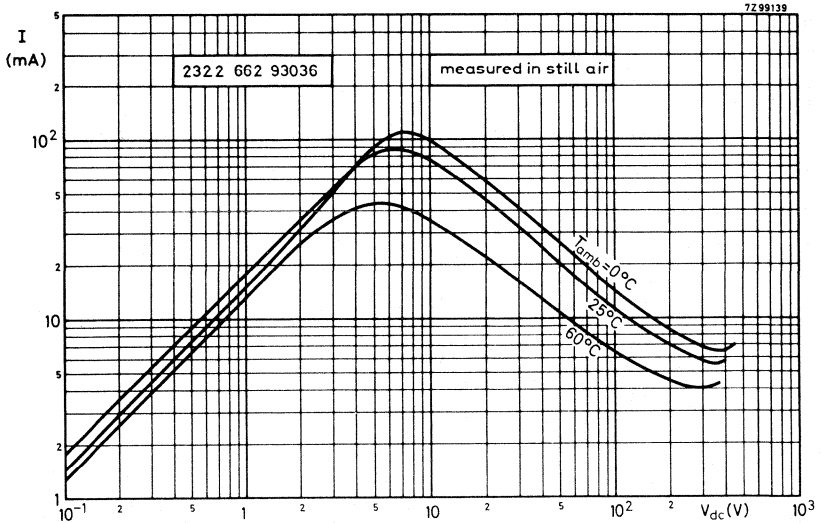

Fig. 2 Typical voltage/current characteristics.

* Measuring voltage not exceeding 1,5 V(d.c.) to avoid internal heating.
 ** Measurement made without internal heating.
 *** Measurement made with specimen in phosphor bronze clips, in still air.

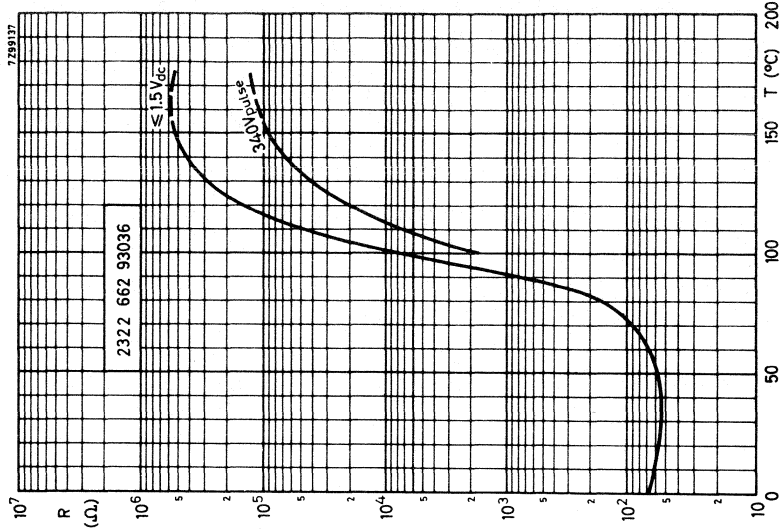

Fig. 4 Typical resistance/time (cooling) characteristics.

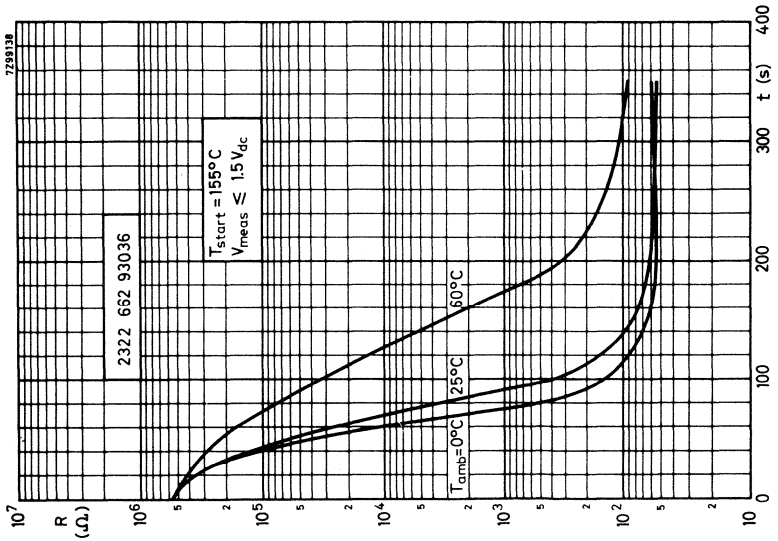

Fig. 3 Typical resistance/temperature characteristics (no internal heating).

PTC THERMISTOR

disc

QUICK REFERENCE DATA

Resistance	
at +25 °C	100 Ω ± 20%
at +155 °C	
V _{pulse} = 380 V	≥ 40 kΩ
Switch temperature	75 °C
Temperature coefficient	+ 35%/K
Maximum r.m.s. voltage	265 V
Dissipation factor	~ 15 mW/K
Operating temperature range	
at zero power	-25 to +155 °C
at V _{max}	0 to +60 °C

APPLICATION

In degaussing circuits of colour television sets.

DESCRIPTION

This thermistor has a positive temperature coefficient. It consists of a disc with two tinned brass wires. The thermistor body is not lacquered.

MECHANICAL DATA

Outlines

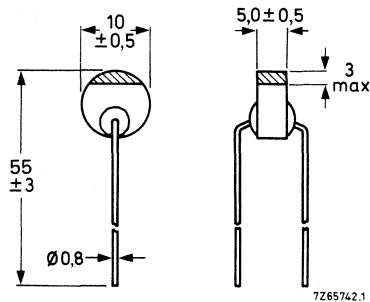

Fig. 1.

Marking	The thermistor is marked with a red colour band on top of the body.
Mass	2,7 g approx.
Mounting	In any position by soldering at min 15 mm from the body.

Robustness of terminations

Tensile strength	20 N
Bending	10 N

Soldering

Solderability	max. 240 °C, max. 4 s
Resistance to heat	max. 240 °C, max. 4 s

PACKAGING

100 thermistors in a cardboard box.

ELECTRICAL DATA

All values in the table without further indication are approximate values.

Resistance value

at +25 °C *	100 Ω ± 20%
at +72 °C *	< 2 × R ₂₅
at +85 °C *	> 2 × R ₂₅
at +155 °C and V _{pulse} = 380 V **	≥ 40 kΩ

Switch temperature

+75 °C

Temperature coefficient

+35%/K

Maximum r.m.s. voltage, with series resistor of 33 Ω

265 V

Dissipation factor ***

15,3 mW/K

Thermal time constant ***

80 s

Heat capacity of complete thermistor ***

1,2 J/K

Balance voltage (d.c.)

190 V

Voltage dependence at 155 °C

0,26

Operating temperature range

at zero power	-25 to +155 °C
at maximum voltage	0 to +60 °C

* Measuring voltage not exceeding 1,5 V d.c. to avoid internal heating.

** Measurement made without internal heating.

*** Measurement made with specimen in phosphor bronze clips, in still air.

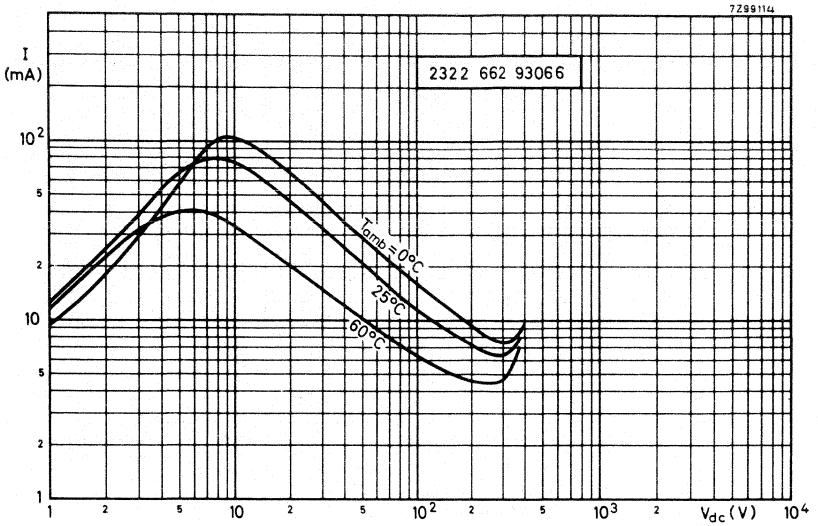

Fig. 3 Typical voltage/current characteristics.

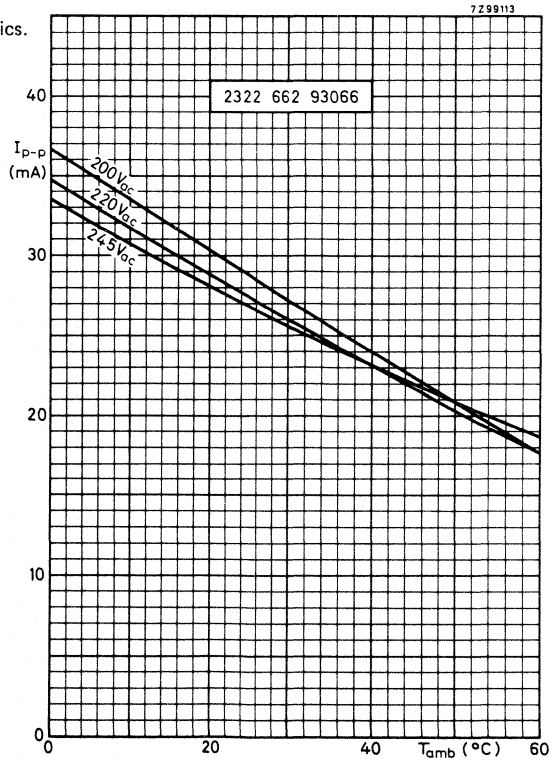

Fig. 4 Typical characteristics of peak to peak current against the ambient temperature at different voltages.

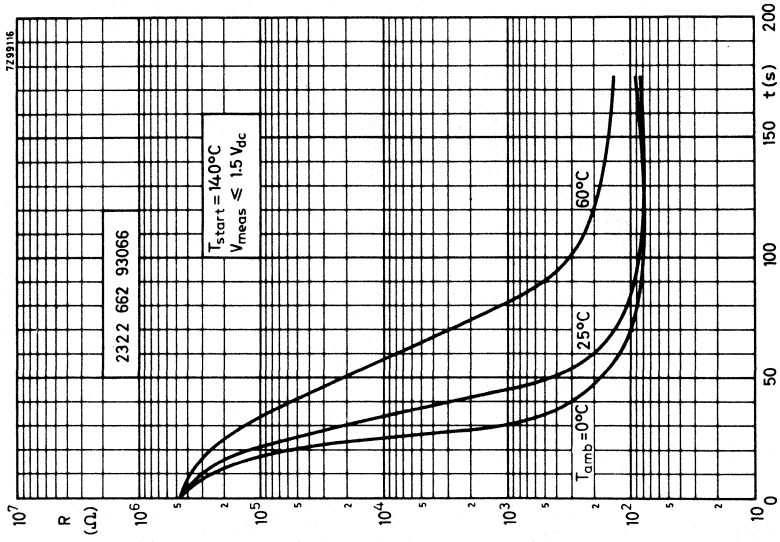

Fig. 6 Typical resistance/time (cooling) characteristics.

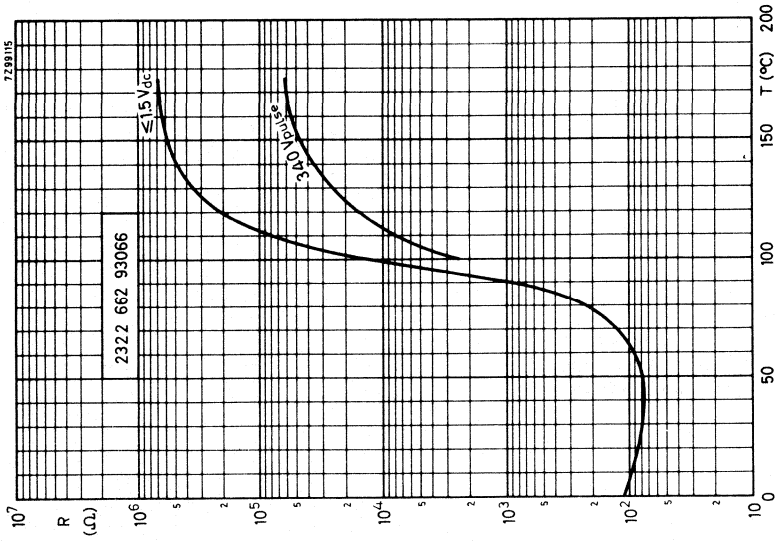

Fig. 5 Typical resistance/temperature characteristics.

DUAL PTC THERMISTOR

parallel-series

QUICK REFERENCE DATA

Current through the coil at 200 V r.m.s.	
min. inrush peak current	5 A
max. peak current	
after 5 s	70 mA
after 30 s	5 mA
after 3 min	2 mA
Maximum r.m.s. voltage	265 V
Operating temperature range	
at zero power	-25 to +125 °C
at maximum voltage	0 to +60 °C

APPLICATION

In degaussing circuits of colour television sets.

DESCRIPTION

The dual PTC consists of two disc PTC thermistors clamped between spring contacts. This assembly ensures a good thermal contact between both discs, which is essential for the function of this device. The thermistor is enclosed in a white plastic housing. The three connecting pins are arranged to fit a printed-wiring board with an 0,1 inch grid.

The parallel PTC thermistor is connected across the supply, the series PTC thermistor is connected in series with the degaussing coil. The series PTC would not by itself lower the current to 2 mA, but would stabilize the current above this value. By applying further heat to the series PTC, its resistance will increase to the point where the coil current is limited to 2 mA. This extra heat is provided by the parallel PTC.

MECHANICAL DATA**Outlines**

A and B are to be connected to the mains;
 A and C are to be connected to the
 degaussing coil (see also Fig. 2).

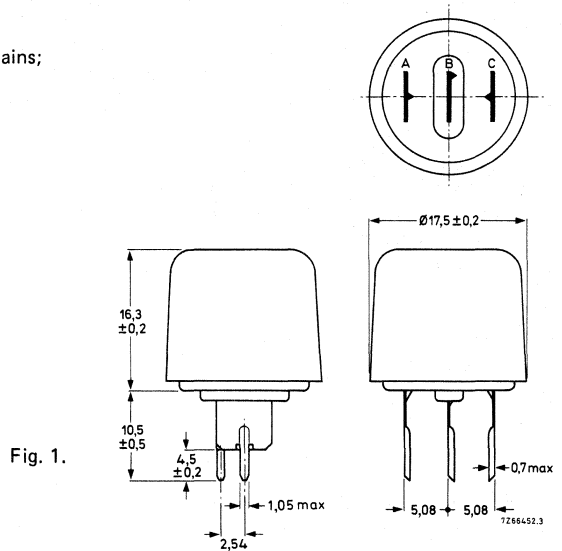

Marking	The catalogue number is moulded in the top of the cap.
Mass	7,3 g approximately
Mounting	The thermistor can be soldered directly onto a printed-wiring board.
Robustness of terminations	
Tensile strength	20 N
Soldering	
Solderability	max. 240 °C, max. 4 s
Resistance to heat	max. 265 °C, max. 11 s
Impact	
Free fall	1000 mm
Inflammability	Uninflammable

PACKAGING

500 thermistors in a cardboard box.

ELECTRICAL DATA

Unless otherwise specified measured according to IEC draft publication 40 (secretariat) 288.

Current through the coil measured
in circuit of Fig. 2 at 200 V r.m.s.

min. inrush peak current	5 A
max. peak current	
after 5 s	70 mA
after 30 s	5 mA
after 3 min	2 mA

Resistance at +25 °C,

R_s	~ 40 Ω
R_p	~ 3000 Ω

Maximum r.m.s. voltage in circuit *

265 V

Minimum degaussing coil resistance

17 Ω ←

Operating temperature range

at zero power, complete assembly	-25 to +125 °C
at zero power, ceramic in free air (10 h max.)	-55 to +225 °C
at maximum voltage	0 to +60 °C

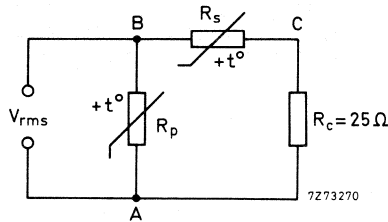

Fig. 2 Measuring circuit.

R_p = parallel PTC;
 R_s = series PTC;
 R_c = replaces the degaussing
 coil ($Z = 25 \Omega$).

* In still air, the thermistor soldered on printed-wiring board.

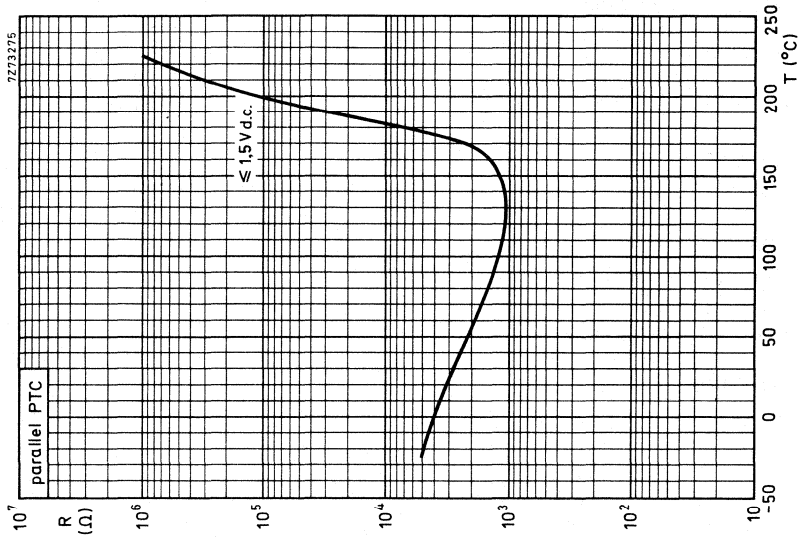

Fig. 4 Typical resistance versus temperature characteristics of the parallel PTC.

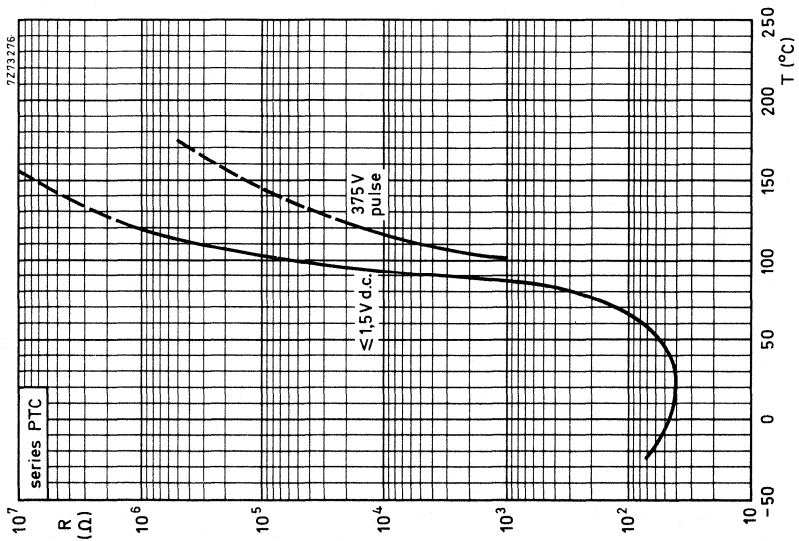

Fig. 3 Typical resistance versus temperature characteristics of the series PTC.

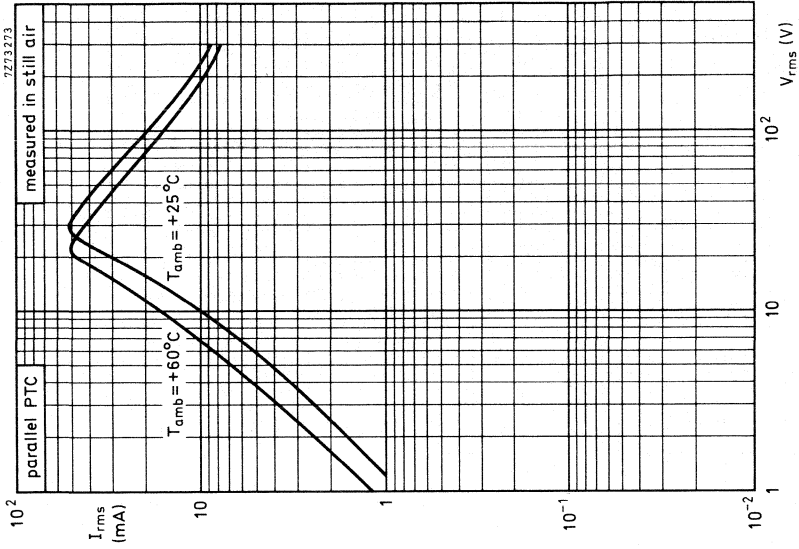

Fig. 6 Typical static current through the parallel PTC versus voltage characteristics.

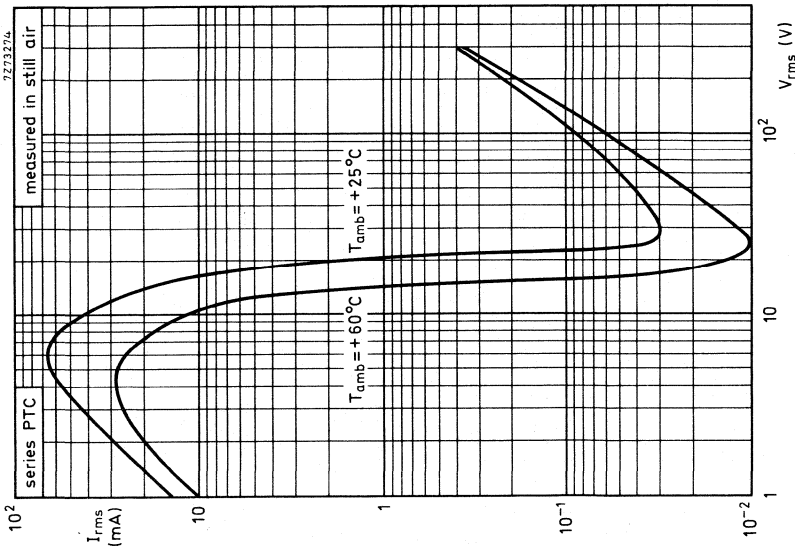

Fig. 5 Typical static current through the coil versus voltage characteristics.

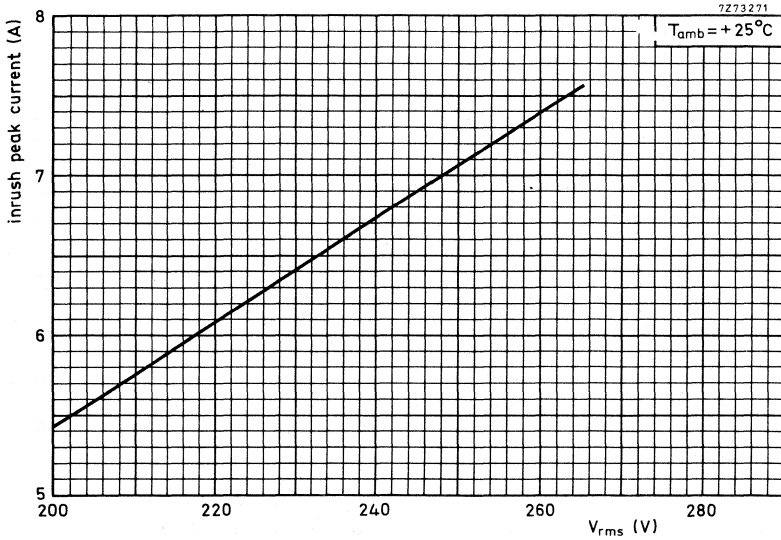

Fig. 7 Typical inrush peak current versus voltage characteristic.

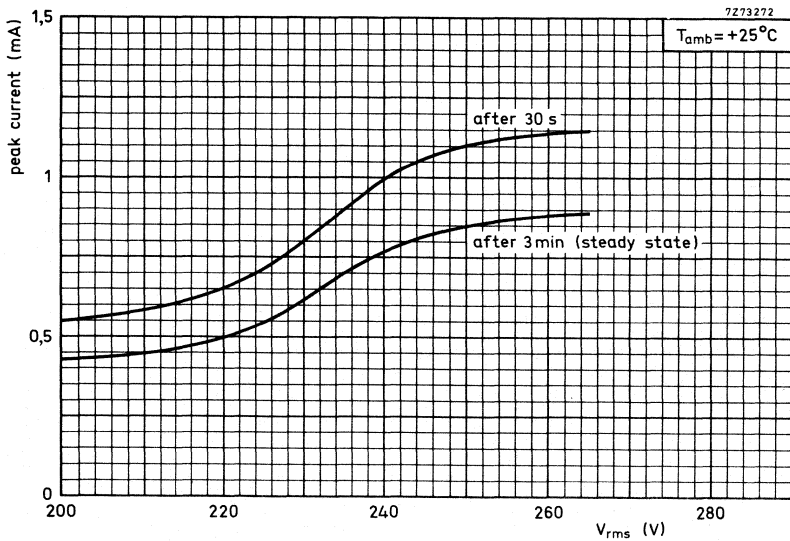

Fig. 8 Typical peak current versus voltage characteristics.

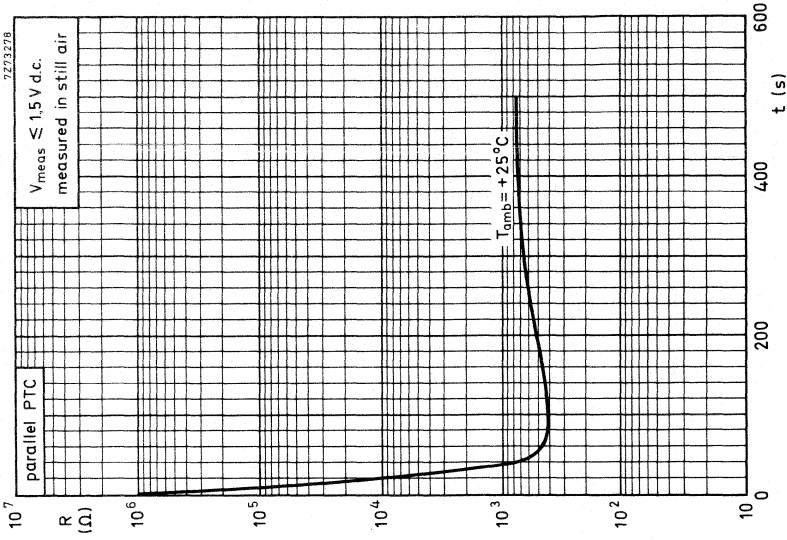

Fig. 10 Typical resistance versus cooling time characteristic of parallel PTC (cooling off after stationary operation at 220 V).

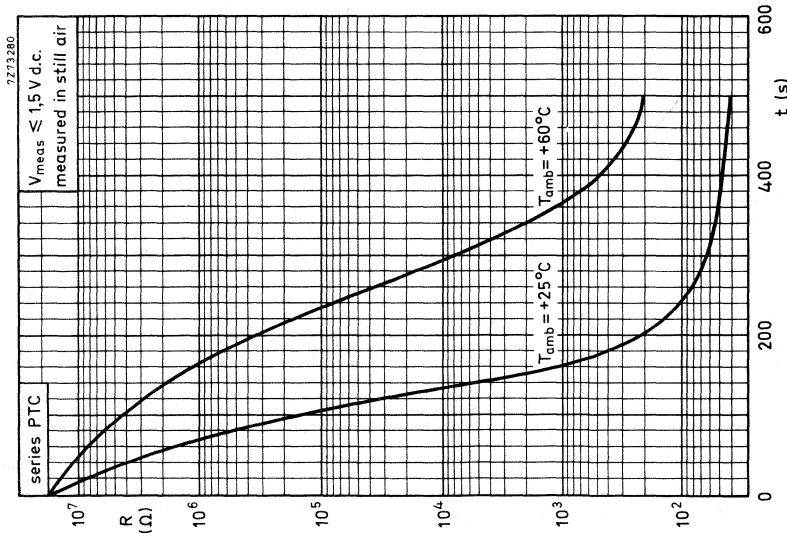

Fig. 9 Typical resistance versus cooling time characteristics of series PTC (cooling off after stationary operation at 220 V).

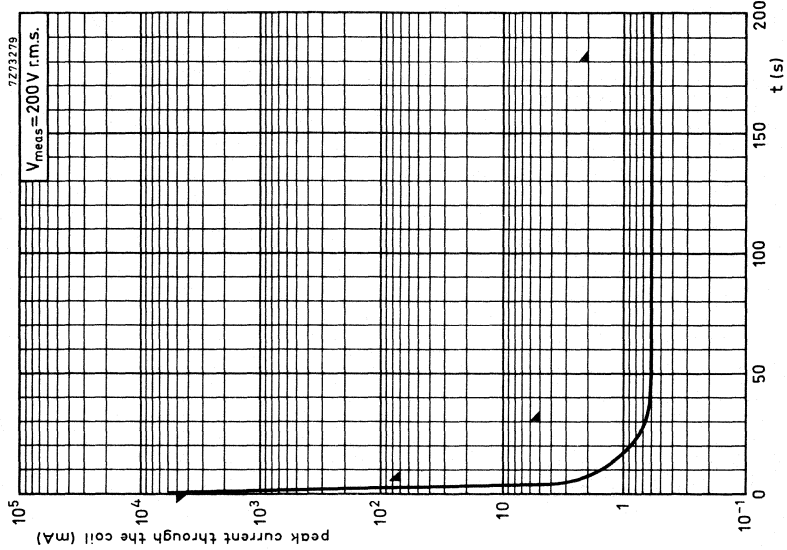

Fig. 12 Typical peak current through the coil versus time characteristic. Peak current limits are indicated by ▲.

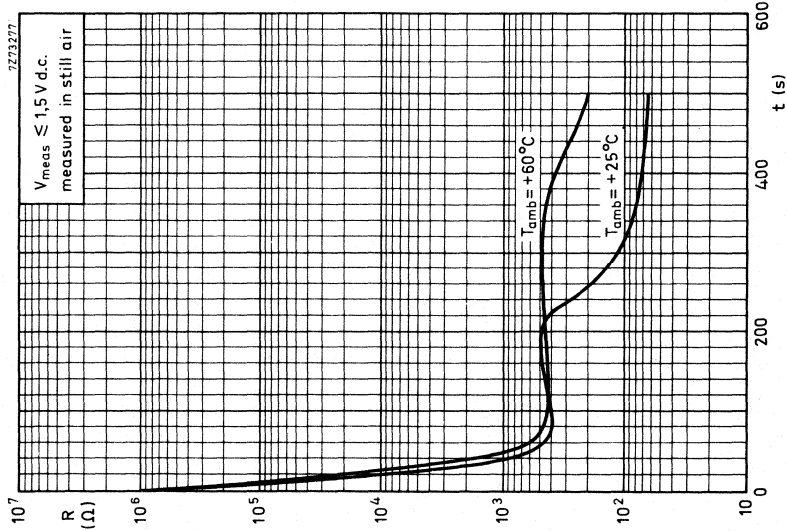

Fig. 11 Typical resistance of circuit versus cooling time characteristics (cooling off after stationary operation at 220 V).

DUAL PTC THERMISTOR

QUICK REFERENCE DATA

Current through the coil at	200 V (r.m.s.)	120 V (r.m.s.)	
Minimum inrush peak current	6,5	3,6	A
Maximum peak current after 30 s	5	5	mA
Maximum peak current after 3 min	2	2	mA
Operating temperature range			
at zero power		-25 to 125	°C
at maximum voltage		0 to 60	°C

APPLICATION

In degaussing circuits of colour television sets, for operation on 120 and 240 V mains supply.

DESCRIPTION

This dual PTC thermistor consists of two discs with a positive temperature coefficient, mounted in a plastic housing. The three connecting pins are arranged to fit a printed wiring board with an 0,1 inch grid.

ELECTRICAL DATA

Unless otherwise specified measured according to IEC draft publication 40/355 of June 1975

Current through the coil measured
in circuit of Fig. 2 at

	200 V (r.m.s.)	120 V (r.m.s.)	
Minimum inrush peak current	6,5	3,6	A
Maximum peak current after 30 s	5	5	mA
Maximum peak current after 3 min	2	2	mA
Resistance at 25 °C of series PTC (R_S)	≈ 35		Ω
Resistance at 25 °C of parallel PTC (R_P)	≈ 1000		Ω
Minimum resistance at 175 °C and 375 V _{pulse} of R_S	130		kΩ
Minimum resistance at 225 °C and 375 V _{pulse} of R_P	25		kΩ
Minimum degaussing coil resistance	16		Ω
Switch temperature of R_S	≈ 65		°C
Switch temperature of R_P	≈ 170		°C
Temperature coefficient of R_S	≈ +26		%/K
Temperature coefficient of R_P	≈ +19		%/K
Maximum r.m.s. voltage in circuit*	265		V
Dissipation factor* (δ)	≈ 12,5		mW/K
Thermal time constant*	≈ 225		s
Operating temperature range at zero power	-25 to 125		°C
at maximum voltage	0 to 60		°C

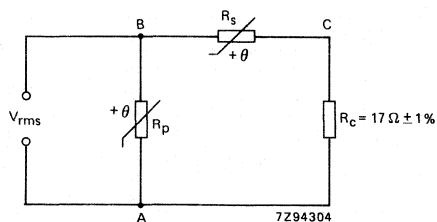

Fig. 2 Measuring circuit.

R_P = parallel PTC;

R_S = series PTC;

R_C = replaces the degaussing
coil ($Z = 17 \Omega$).

* In still air, the thermistor soldered on printed-wiring board.

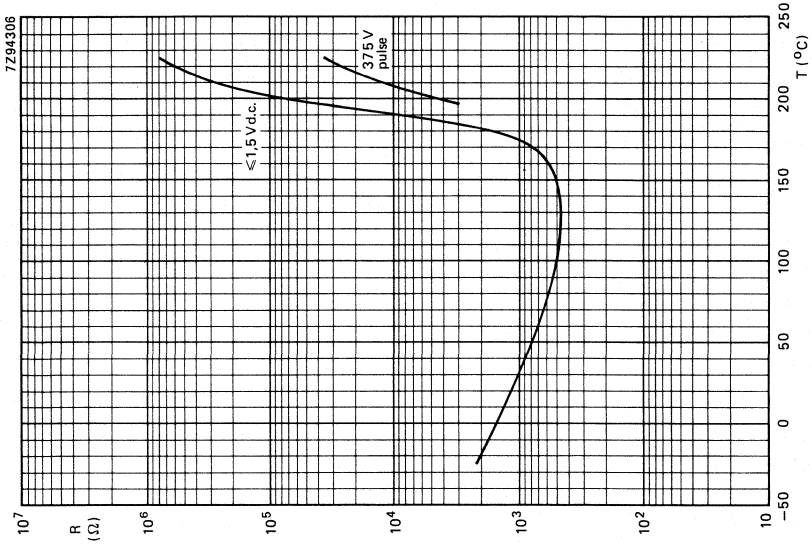

Fig. 4 Typical resistance versus temperature characteristics of the parallel PTC.

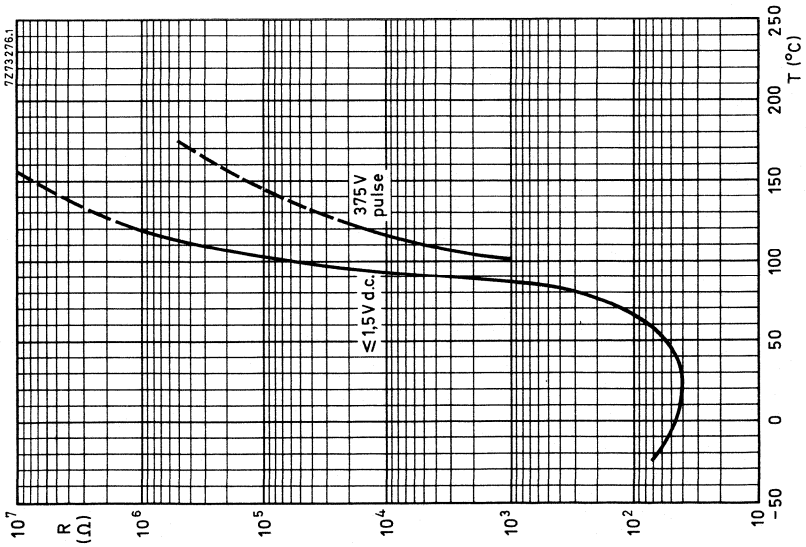

Fig. 3 Typical resistance versus temperature characteristics of the series PTC.

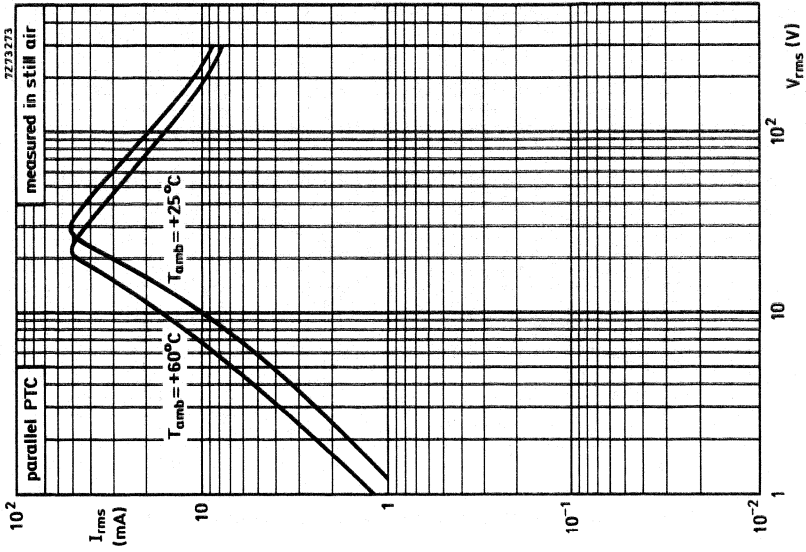

Fig. 6 Typical static current through the parallel PTC versus voltage characteristics.

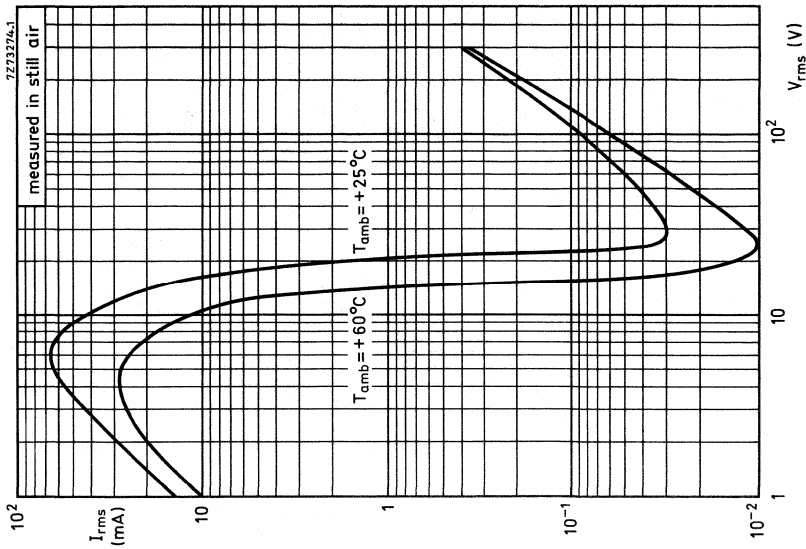

Fig. 5 Typical static current through the coil versus voltage characteristics.

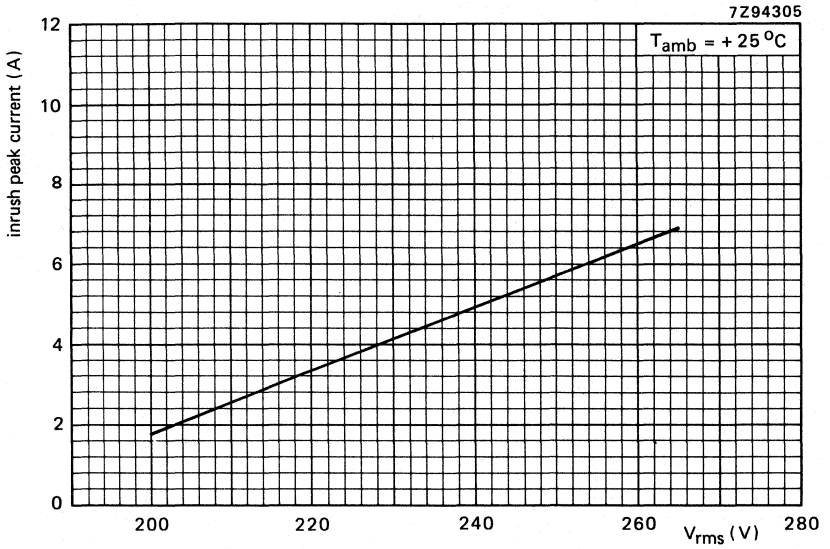

Fig. 7 Typical inrush peak current versus voltage characteristic.

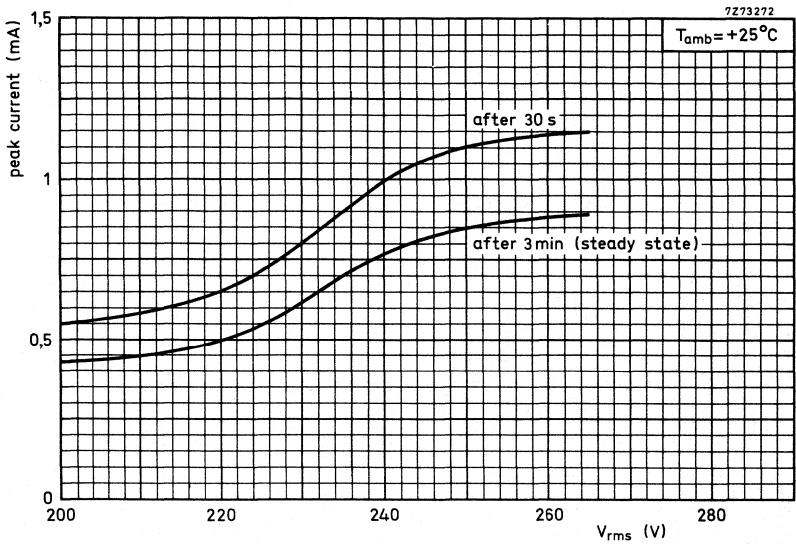

Fig. 8 Typical peak current versus voltage characteristics.

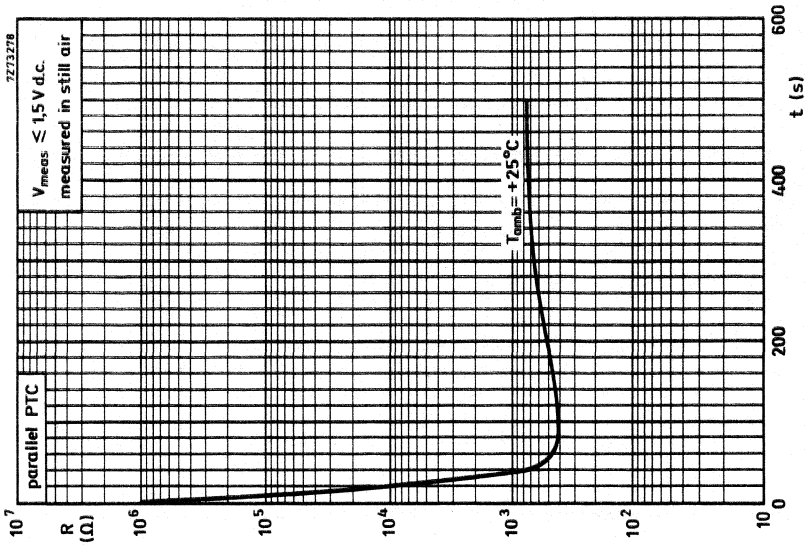

Fig. 10 Typical resistance versus cooling time characteristic of parallel PTC, $T_{start} = 225^{\circ}\text{C}$.

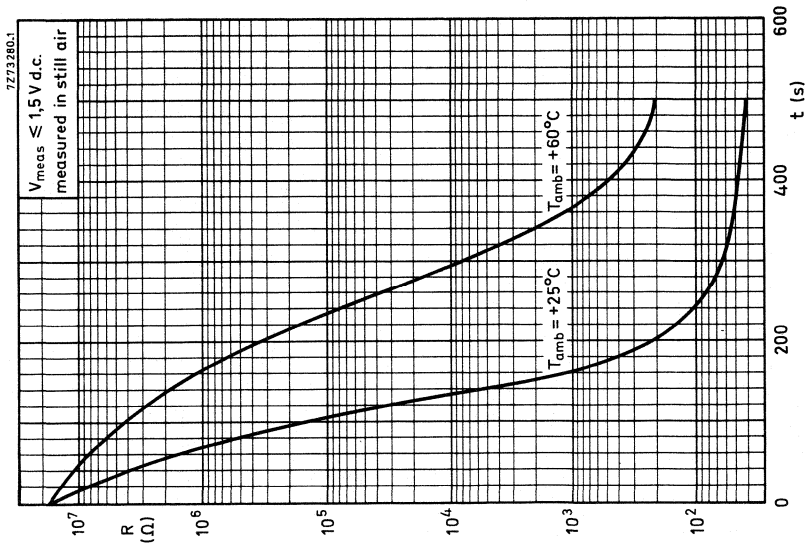

Fig. 9 Typical resistance versus cooling time characteristics of series PTC, $T_{start} = 175^{\circ}\text{C}$.

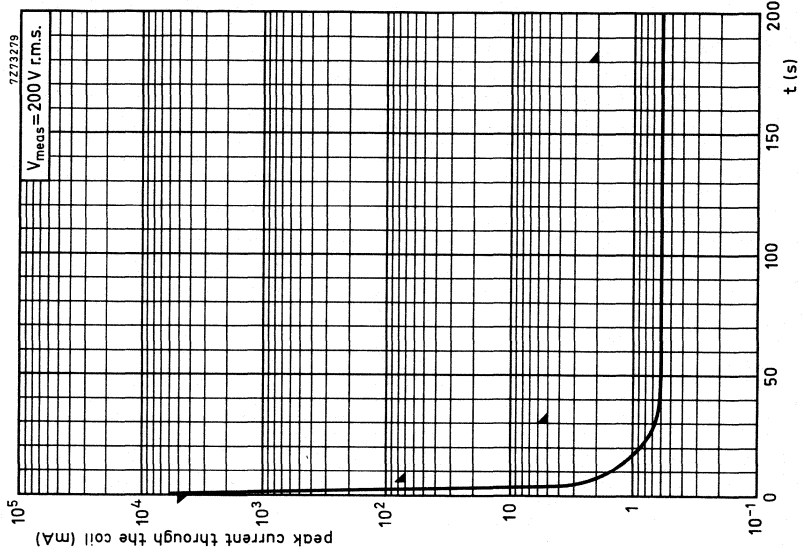

Fig. 12 Typical peak current through the coil versus time characteristic. Peak current limits are indicated by ▲ . . .

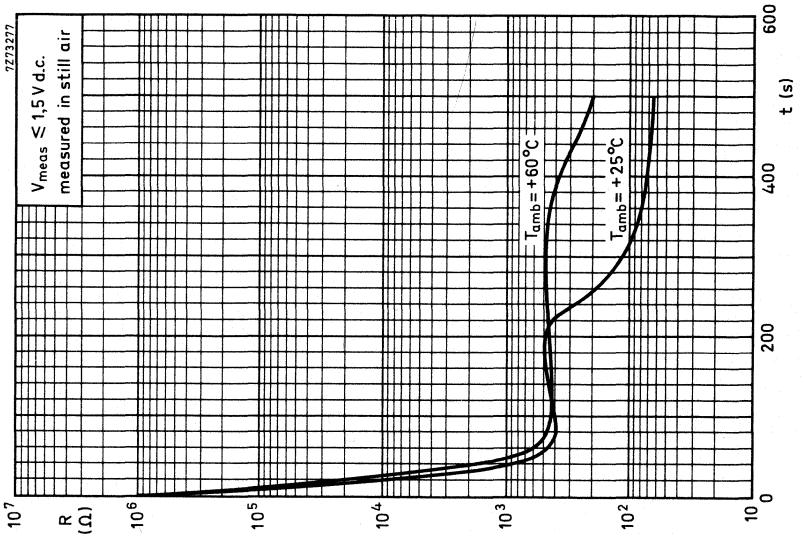

Fig. 11 Typical resistance of circuit versus cooling time characteristics, $T_{start} = 225^\circ\text{C}$.

DUAL PTC THERMISTOR

QUICK REFERENCE DATA

Current through the coil measured at 100 V r.m.s.	
min. inrush peak current	10 A
max. idle peak current	
after 5 s	140 mA
after 30 s	10 mA
after 3 min	5 mA
Maximum voltage (r.m.s.)	145 V
Switch temperature	
of series PTC	+70 °C
of parallel PTC	+170 °C
Operating temperature range	
at zero power	-25 to +125 °C
at maximum voltage	0 to +60 °C

APPLICATION

In the degaussing circuit of colour television sets.

DESCRIPTION

The thermistor consists of two disc PTC thermistors clamped between stainless steel contacts. This assembly ensures a good thermal contact between both discs, which is essential for the function of this device. The thermistor is enclosed in a plastic housing. The three connecting pins are arranged to fit a printed-wiring board with a 0,1 inch grid.

ELECTRICAL DATA

All values are approximate unless otherwise specified.

Current through the coil measured in circuit of Fig. 2 at 100 V r.m.s.

min. inrush current	10 A
max. idle peak current	
after 5 s	140 mA
after 30 s	10 mA
after 3 min	5 mA

Resistance at +25 °C

of series PTC	10 Ω
of parallel PTC	400 to 2400 Ω
at $T_{amb} = +200$ °C and 198 V pulsed	
of parallel PTC	> 10 kΩ

Switch temperature

of series PTC	+70 °C
of parallel PTC	+170 °C

Temperature coefficient

of series PTC	+16%/K
of parallel PTC	+20%/K

Maximum voltage (r.m.s.) in circuit of Fig. 2

145 V

Operating temperature range

at zero power	-25 to +125 °C
at maximum voltage	0 to +60 °C

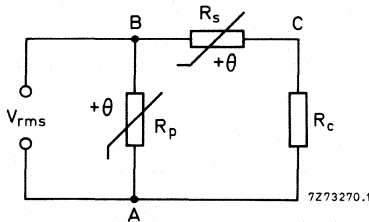

Fig. 2 Measuring circuit.

R_p = parallel PTC;

R_s = series PTC;

R_c = 6,2 Ω (replaces degaussing coil).

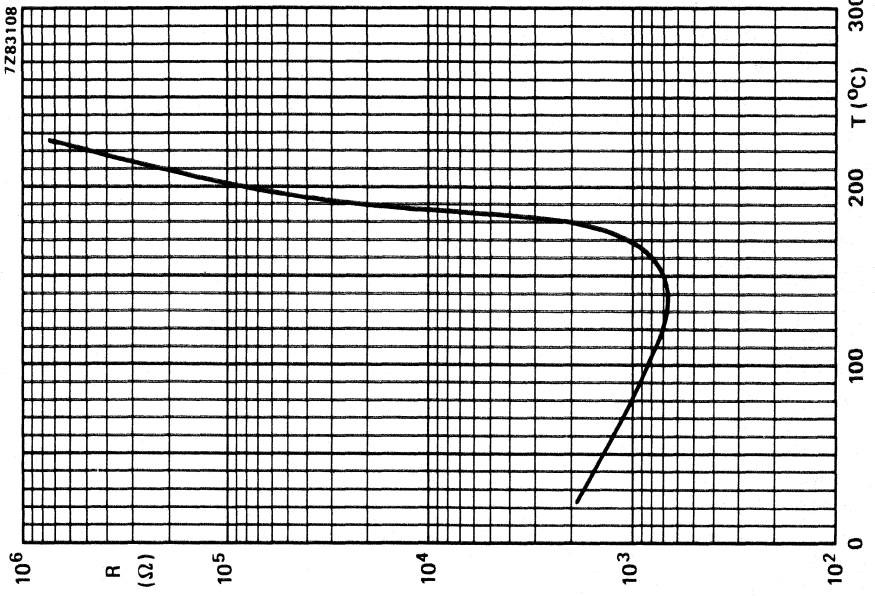

Fig. 4 Parallel PTC.

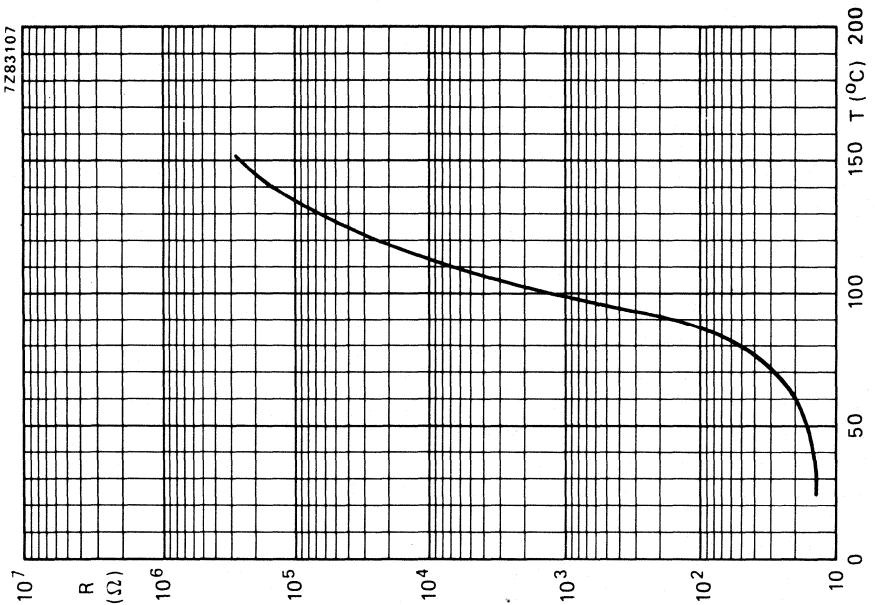

Fig. 3 Series PTC.

Typical resistance/temperature characteristics.

DUAL PTC THERMISTOR

QUICK REFERENCE DATA

Current through the coil at 200 V r.m.s.

min. inrush peak current	5 A
max. peak current	
after 5 s	70 mA
after 30 s	5 mA
after 3 min	1 mA

Maximum r.m.s. voltage

265 V

Operating temperature range

at zero power	-25 to +125 °C
at maximum voltage	0 to +60 °C

APPLICATION

In degaussing circuits of colour monitors where very low residual current in the degaussing coil is necessary.

DESCRIPTION

This dual PTC thermistor consists of two discs with a positive temperature coefficient, mounted in a plastic housing. The three connecting pins are arranged to fit a printed wiring board with an 0,1 inch grid.

MECHANICAL DATA**Outlines**

A and B are to be connected to the mains;
A and C are to be connected to the
degaussing coil (see Fig. 2).

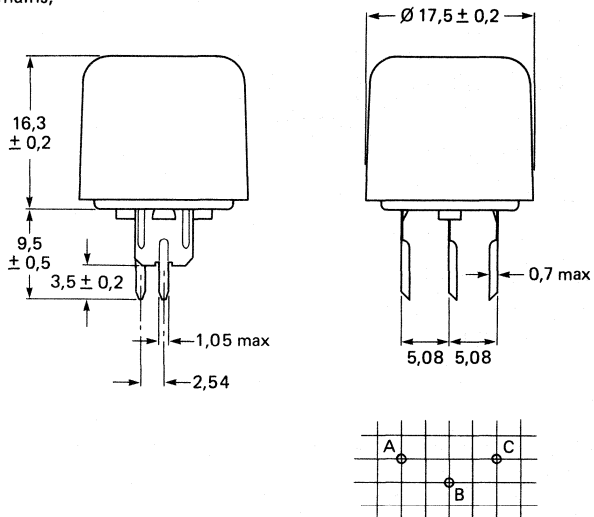

7295377

Fig. 1.

- Marking** The catalogue number is moulded in the top of the cap.
- Mass** 7,3 g approximately
- Mounting** The thermistor can be soldered directly onto a printed-wiring board.
- Robustness of terminations**
- Tensile strength 20 N
- Soldering**
- Solderability max. 240 °C, max. 4 s
- Resistance to heat max. 265 °C, max. 11 s
- Impact**
- Free fall 1000 mm
- Inflammability** Unflammable, according to IEC 695-2-2 (1980)

PACKAGING

500 thermistors in a cardboard box.

ELECTRICAL DATA

Unless otherwise specified measured according to IEC draft publication 738-1 (1982)

Current through the coil measured
in circuit of Fig. 3 at 200 V (r.m.s.)

Minimum inrush peak current	5 A
Maximum peak current	
after 5 s	70 mA
after 30 s	5 mA
after 3 min	1 mA

Inrush current decrease

For voltages between 200 and 245 V_{rms} and series resistor of 17 ohm

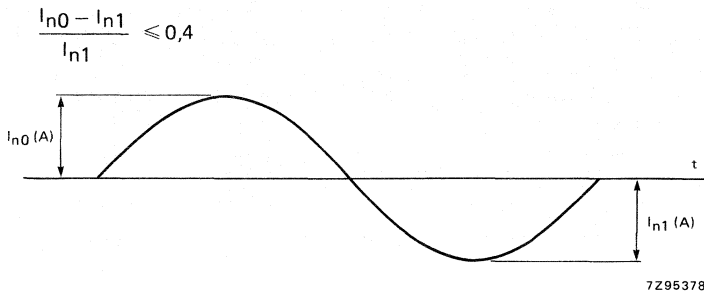

Fig. 2.

Resistance at 25 °C of series PTC (R _S)	≈	40 Ω
Resistance at 25 °C of parallel PTC (R _P)	≈	3000 Ω
Minimum resistance at 175 °C and 375 V _{pulse} of R _S		100 kΩ
Minimum resistance at 225 °C and 375 V _{pulse} of R _P		25 kΩ
Degaussing coil impedance range		17 to 25 Ω
Switch temperature of R _S	≈	65 °C
Switch temperature of R _P	≈	170 °C
Maximum r.m.s. voltage in measuring circuit (Fig. 3)		265 V
Operating temperature range		
at zero power		-25 to 125 °C
at maximum voltage		0 to 60 °C

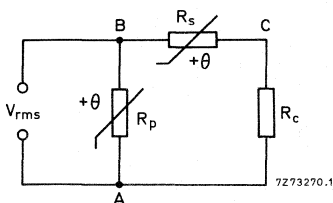

Fig. 3 Measuring circuit.

R_P = parallel PTC;
R_S = series PTC;
R_C = replaces the degaussing coil (Z = 25 Ω).

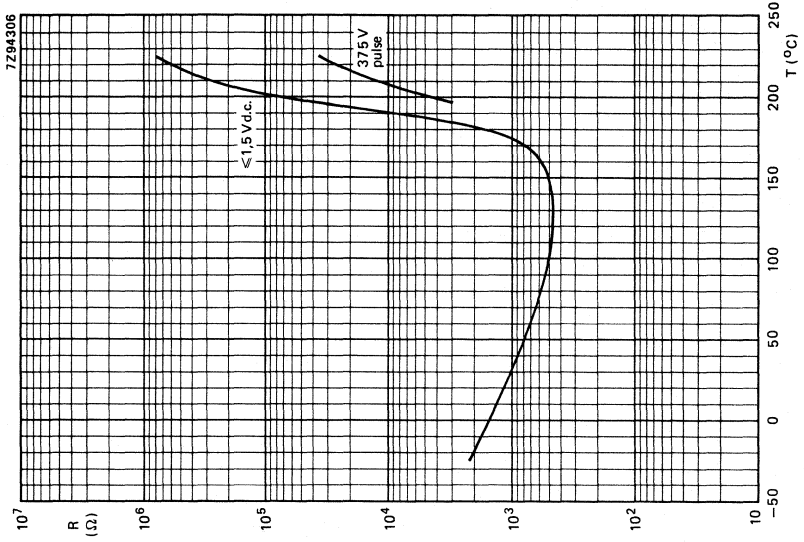

Fig. 5 Typical resistance versus temperature characteristics of the parallel PTC.

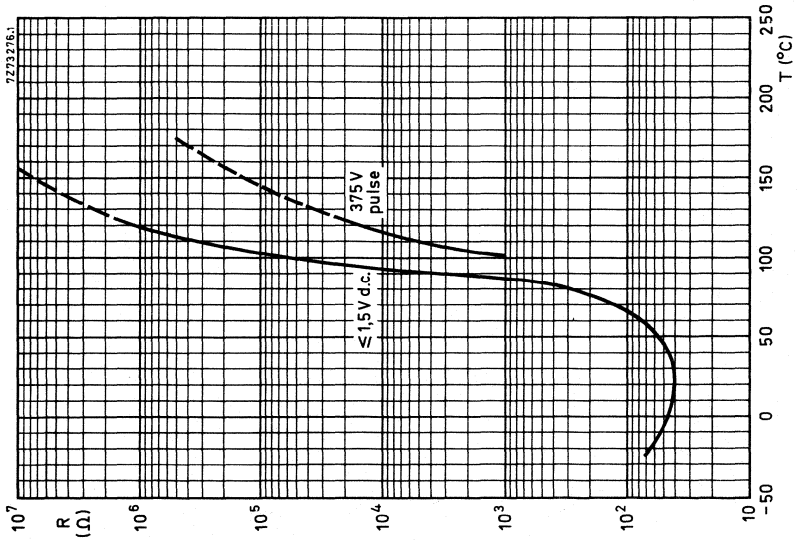

Fig. 4 Typical resistance versus temperature characteristics of the series PTC.

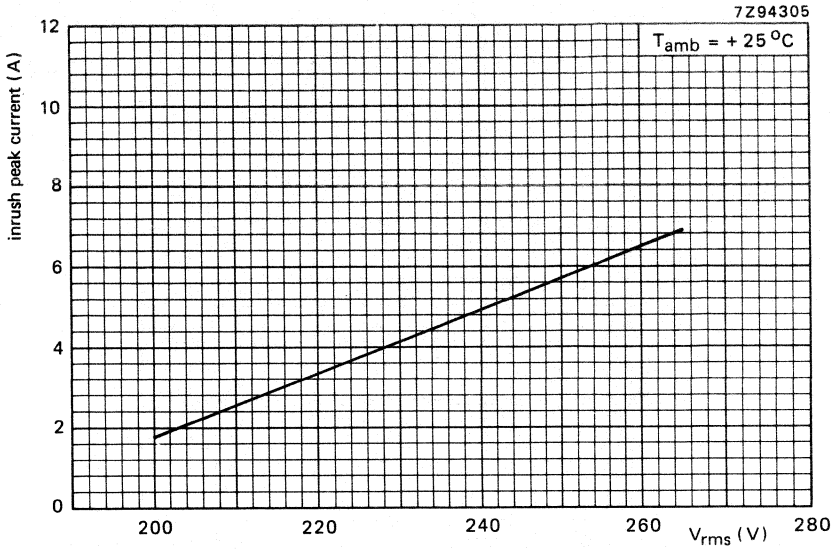

Fig. 6 Typical inrush peak current versus voltage characteristic.

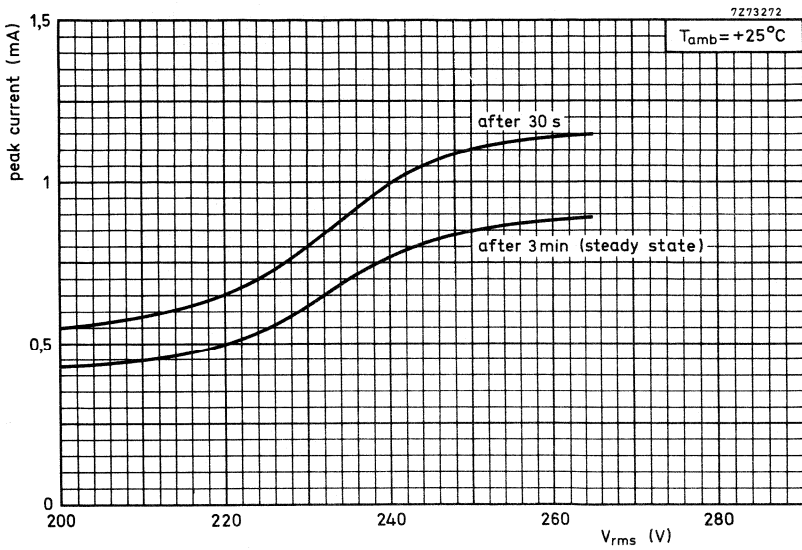

Fig. 7 Typical peak current versus voltage characteristics.

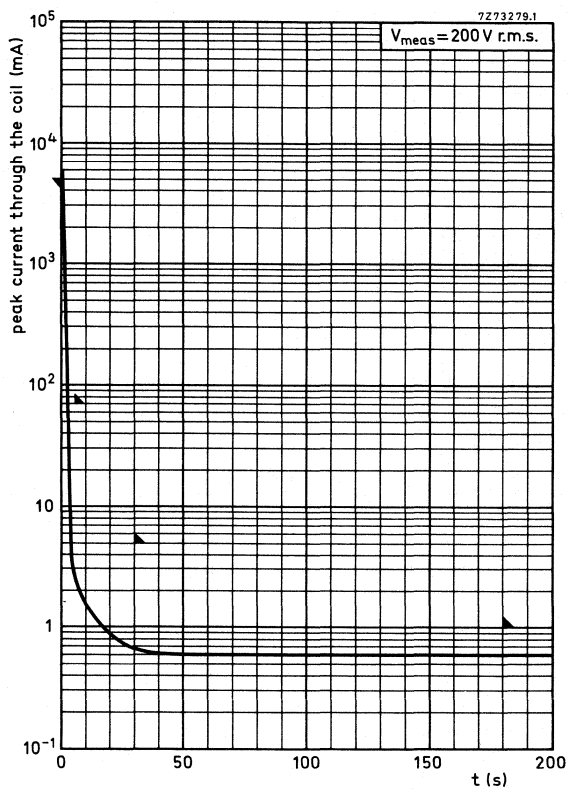

Fig. 8 Typical peak current through the coil versus time characteristic. Peak current limits are indicated by \blacktriangle . .

PTC THERMISTOR

disc

QUICK REFERENCE DATA

Resistance value at +25 °C	max. 1,1 Ω
Resistance value at +85 °C	max. 0,9 Ω
Switch temperature	+140 °C
Temperature coefficient	+8%/K
Maximum r.m.s. voltage	18 V
Operating temperature range	
at zero power	-25 to +175 °C
at maximum voltage	0 to +85 °C

APPLICATION

Overload protection, e.g. of loudspeakers.

DESCRIPTION

This positive temperature coefficient thermistor consists of a disc with two tinned brass wires.

MECHANICAL DATA

Outlines

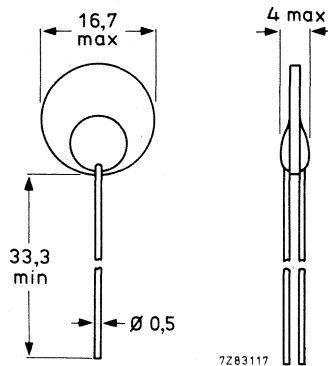

Fig. 1.

PACKAGING

2000 thermistors in a cardboard box.

Marking	none
Mass	1,25 g approximately
Mounting	in any position by soldering
Robustness of terminations	
Tensile strength	10 N
Bending	5 N
Soldering	
Solderability	max. 240 °C, max. 4 s
Resistance to heat	max. 265 °C, max. 11 s
Impact	200 mm free fall
Inflammability	uninflammable
ELECTRICAL DATA	
Resistance at +25 °C	max. 1,1 Ω
Resistance at +85 °C	max. 0,9 Ω
Switch temperature	+140 °C approx.
Switching current at $T_{amb} = +25\text{ °C}$	max. 1,17 A
Max. current at which no switching occurs at $T_{amb} = +25\text{ °C}$	0,95 A
Temperature coefficient	+8%/K approx.
Maximum voltage (r.m.s.)	18 V
Steady state current at $T_{amb} = +25\text{ °C}$, $V_{rms} = 18\text{ V}$	max. 140 mA
Response time at $T_{amb} = +25\text{ °C}$, $I = 2\text{ A}$	max. 15 s
Operating temperature range at zero power	-25 to +175 °C
at maximum voltage	0 to +85 °C

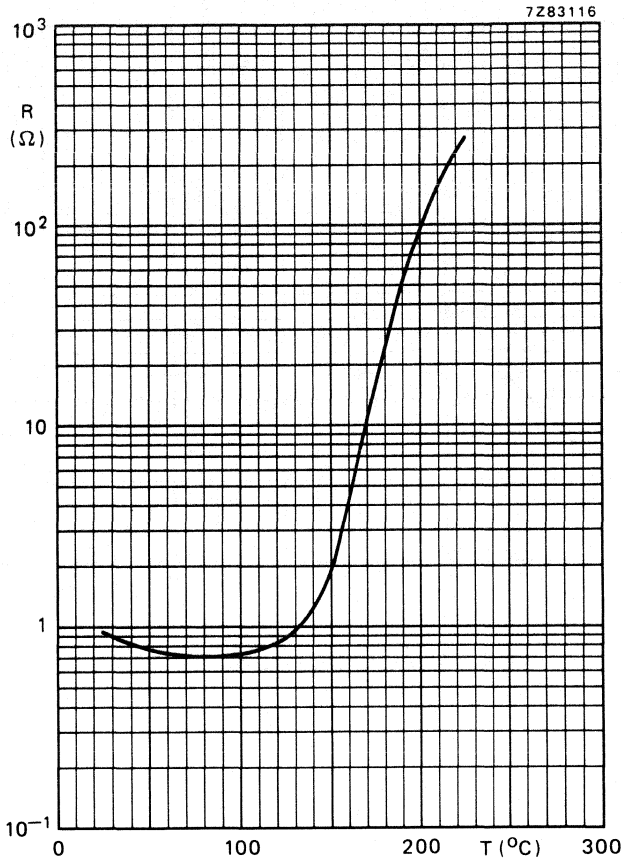

Fig. 2 Typical resistance/temperature characteristic.

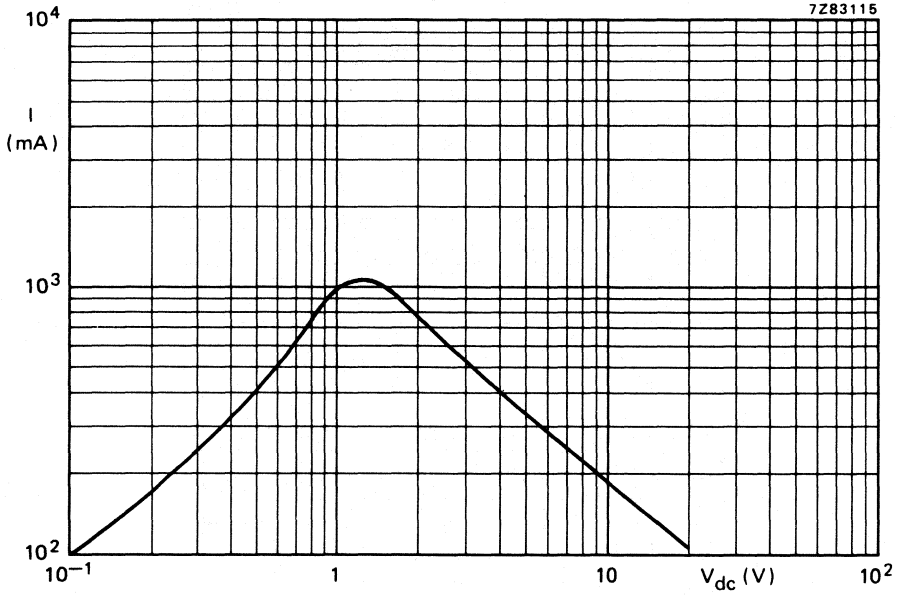

Fig. 3 Typical voltage/current characteristic.

PTC THERMISTOR

disc

QUICK REFERENCE DATA

Resistance value at +25 °C	max. 0,6 Ω
Resistance value at +150 °C V _{pulse} = 16 V	min. 40 Ω
Switch temperature	+85 °C
Temperature coefficient	+10%/K
Maximum d.c. voltage	16 V
Dissipation factor	27 mW/K
Operating temperature range at zero power	-25 to +155 °C
at V _{max}	-25 to +55 °C

APPLICATION

Overload protection, e.g. of relay coils, loudspeakers, etc.

DESCRIPTION

The thermistor has a positive temperature coefficient. It consists of a disc with two tinned copper wires. The thermistor body is blue lacquered, but not insulated.

MECHANICAL DATA

Outlines

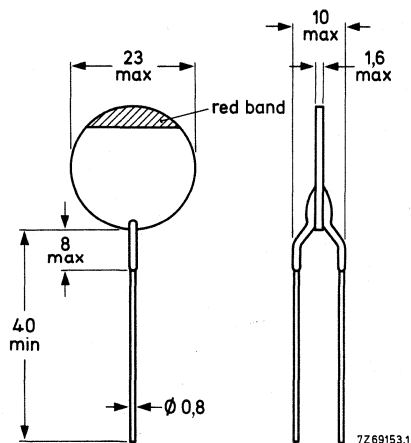

Fig. 1.

PACKAGING

100 thermistors in a cardboard box.

Marking	The thermistors are marked with a red band.
Mass	~ 2,3 g
Mounting	In any position by soldering
Robustness of terminations	
Tensile strength	20 N
Bending	10 N
Soldering	
Solderability	max. 240 °C, max. 4 s
Resistance to heat	max. 240 °C, max. 4 s
ELECTRICAL DATA	
Resistance at -25 °C	max. 1,15 Ω *
Resistance between +25 and +55 °C	max. 0,6 Ω *
Resistance at +150 °C	
V _{pulse} = 16 V	min. 40 Ω **
Switch temperature	~ +83 °C
Temperature coefficient	~ 10%/K
Dissipation factor	~ 27 mW/K
Heat capacity	~ 1,2 J/K
Thermal time constant	~ 45 s
Operating temperature range	
at zero power	-25 to +155 °C
at maximum voltage	-25 to +55 °C
Maximum voltage (d.c.)	16 V

* D.C. measuring voltage not exceeding 1,5 V to avoid internal heating.

** Measurement made without internal heating.

*** Measurements made with specimen in phosphor bronze clips, in still air.

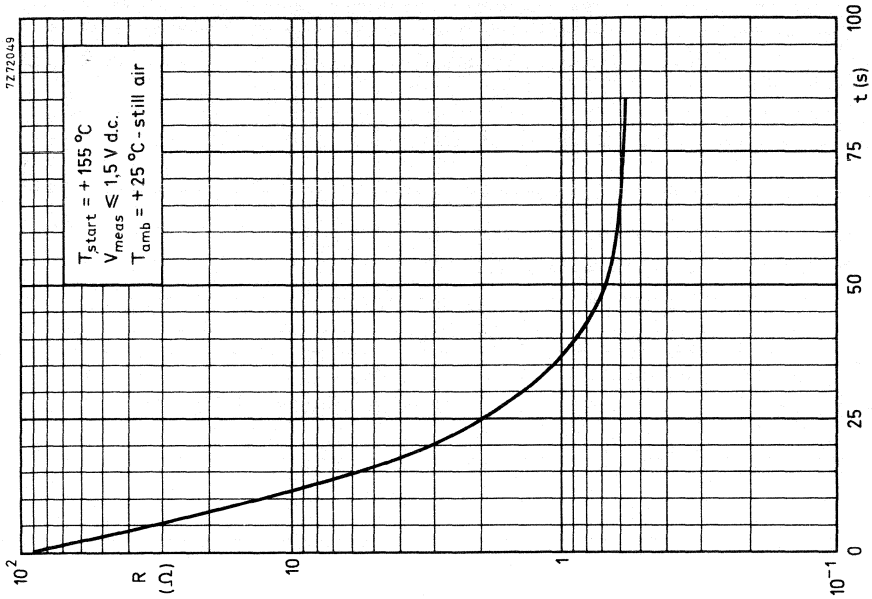

Fig. 3 Typical resistance/time (cooling) characteristic.

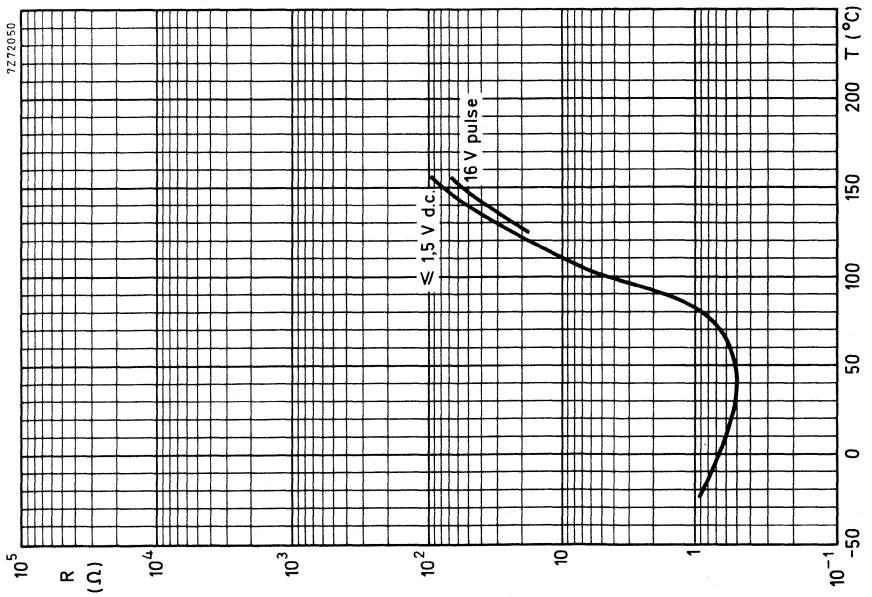

Fig. 2 Typical resistance/temperature characteristics.

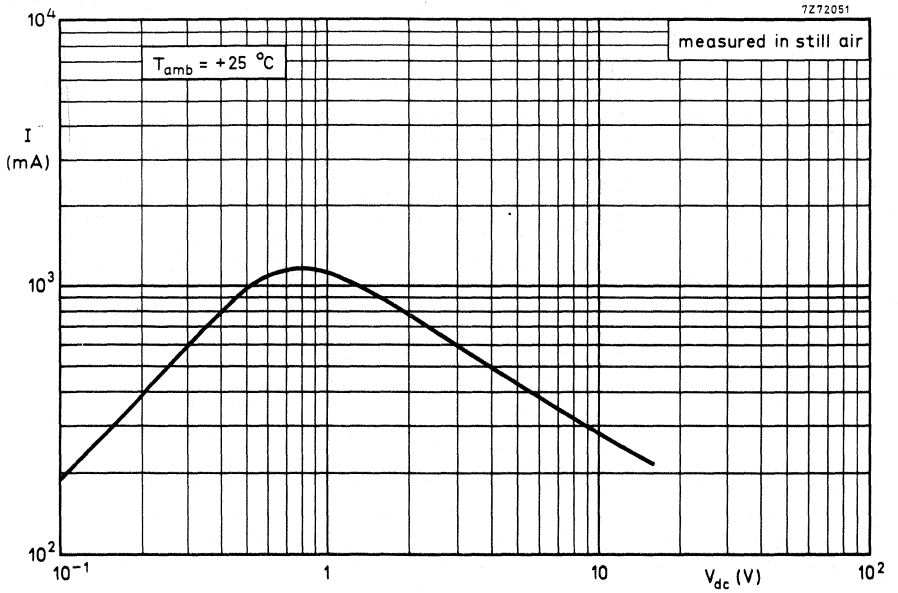

Fig. 4 Typical voltage/current characteristic.

PTC THERMISTOR

QUICK REFERENCE DATA

Resistance	
at +25 °C	$120 \pm 30 \Omega$
at +155 °C	$> 2 \text{ k}\Omega$
Switch temperature	$\approx 145 \text{ }^\circ\text{C}$
Temperature coefficient	$> 8\%/K$
Maximum voltage (d.c.) at +40 °C	34 V
Response time	$\leq 2 \text{ S}$
Operating temperature range	
at zero power	$-25 \text{ to } +155 \text{ }^\circ\text{C}$
at maximum voltage	$0 \text{ to } +40 \text{ }^\circ\text{C}$

APPLICATION

Current stabilizer for compensation of variation in telephone line resistance.

DESCRIPTION

A miniature thermistor element mounted in a glass envelope model DO-7 with two axial leads.

MECHANICAL DATA

Outlines

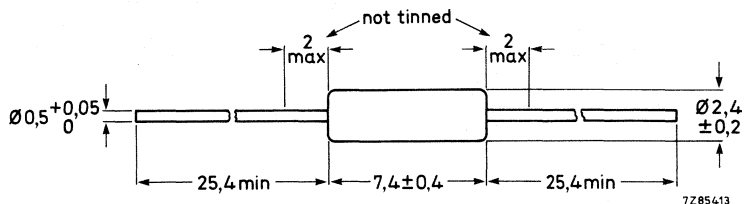
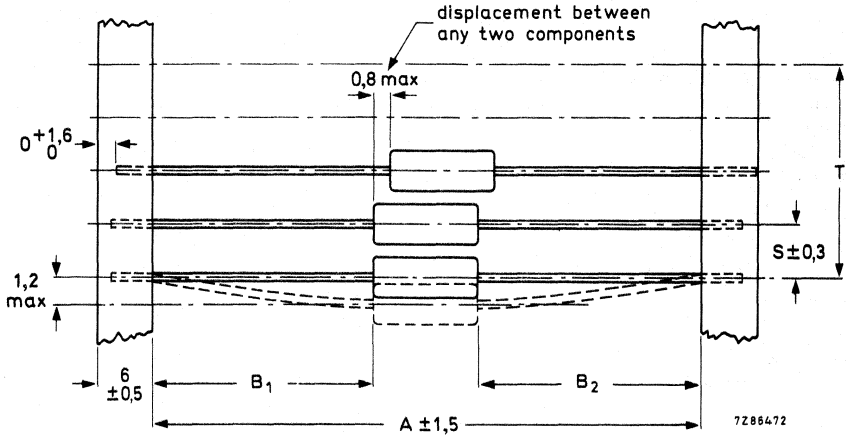

Fig. 1.

STANDARD PACKAGING

The thermistors are supplied in quantities of 5000 on bandolier which is zig-zag folded in an ammpack. Configuration of bandolier



style	A	$B_1 - B_2$ \pm max.	S (spacing)	T (max. deviation of spacing)
TPJ	53	1,2	5	2 mm for 10 spacings, 1,5 mm for 5 spacings

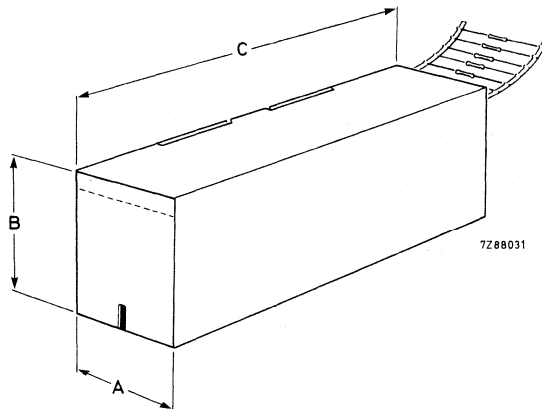

Fig. 3 Dimensions of ammpack in mm.

- A = 75 mm
- B = 95 mm
- C = 270 mm

PTC THERMISTORS

disc

QUICK REFERENCE DATA

Resistance value between -20 and $(T_s - 10)$ °C	30 to 250 Ω
Resistance value at $(T_s + 25)$ °C and $V_{\text{pulse}} = 7,5$ V	≥ 4000 Ω
Switch temperature, T_s	70 to 150 °C
Temperature coefficient	18 to 38%/K
Maximum voltage (d.c.)	25 V
Dissipation factor (version with leads)	5,7 mW/K
Operating temperature range	
at zero power	-25 to $(T_s + 40)$ °C
at maximum voltage	0 to $(T_s + 25)$ °C

APPLICATION

Temperature sensors in domestic appliances, fire alarms, car electronics, etc.

DESCRIPTION

These thermistors have a positive temperature coefficient. They consist of a disc with or without two tinned copper wires. The thermistor without leads is not lacquered nor insulated. The thermistor with leads is lacquered but not insulated.

MECHANICAL DATA

Outlines

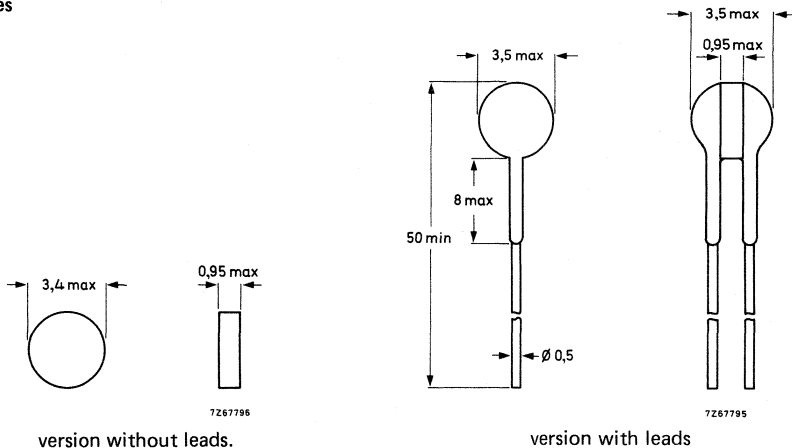

Fig. 1.

2322 672 91002
to
2322 672 91035

Marking

Version without leads

none

Version with leads

colour code, see table

Mass

Version without leads

0,04 g approx.

Version with leads

0,29 g approx.

Mounting (for version with leads only)

In any position by soldering.

Robustness of terminations (for version with leads only)

Tensile strength

10 N

Bending

5 N

Soldering (for version with leads only)

Solderability

max. 240 °C, max. 4 s

Resistance to heat

max. 265 °C, max. 11 s

Impact

Free fall

PACKAGING

Version without leads: 5000 thermistors in a cardboard box.

Version with leads: 500 thermistors in a cardboard box.

ELECTRICAL DATA

All values in the electrical data without further indication are approximate values.

T _s °C	temperature coefficient %/K	balance voltage V d.c.	voltage dependence β at (T _s + 25) °C	colour code for version with leads	catalogue number 2322 672	
					with leads	without leads
70	18	19	0,32	violet	91002	91026
80	21	27	0,40	grey	91003	91027
90	31	16	0,36	white	91004	91028
100	33	17	0,35	black	91005	91029
110	38	11	0,36	brown	91006	91031
120	27	34	0,38	red	91007	91032
130	33	13	0,34	orange	91008	91033
140	33	20	0,35	yellow	91009	91034
150	23	20	0,31	green	91011	91035

Resistance value between -20 and (T _s - 10) °C	30 to 250 Ω *
Resistance value at (T _s + 5) °C	≤ 550 Ω *
Resistance value at (T _s + 15) °C	≥ 1330 Ω *
Resistance value at (T _s + 25) °C, V _{pulse} = 7,5 V	≥ 4000 Ω **
Maximum voltage (d.c.)	25 V
Dissipation factor (version with leads)	5,7 mW/K
Thermal time constant (version with leads)	9 s
Heat capacity (version with leads)	0,05 J/K
Operating temperature range	
at zero power	-25 to (T _s + 40) °C
at maximum voltage	0 to (T _s + 25) °C

* Measuring voltage not exceeding 2,5 V d.c. to avoid internal heating.

** Measurements made without internal heating occurring.

2322 672 91002
to
2322 672 91035

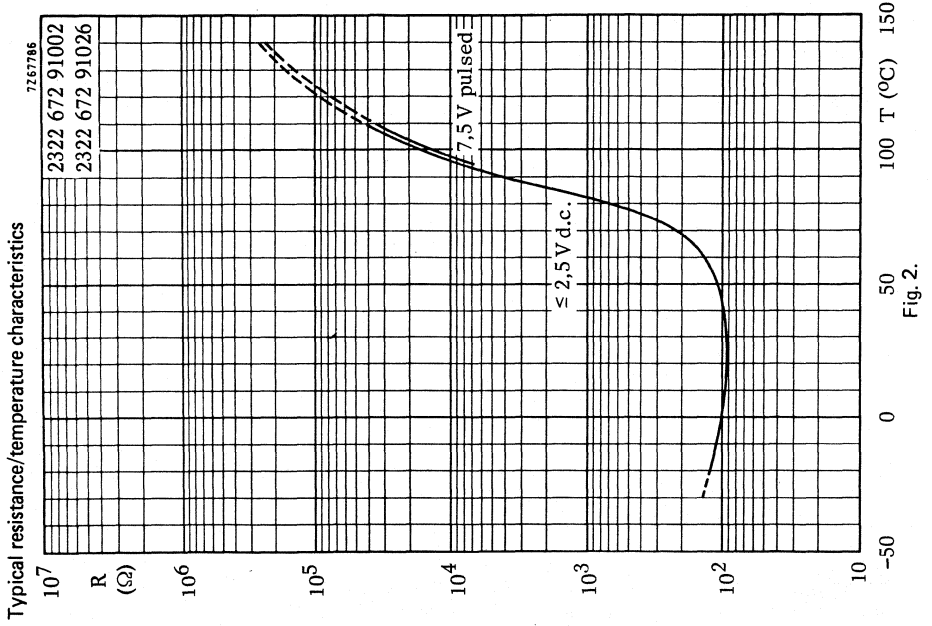

Fig. 2.

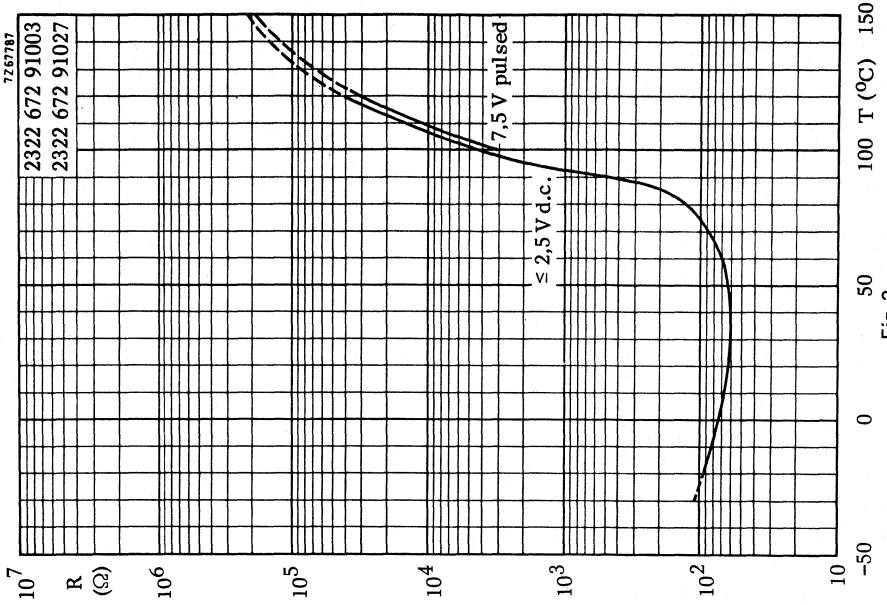

Fig. 3.

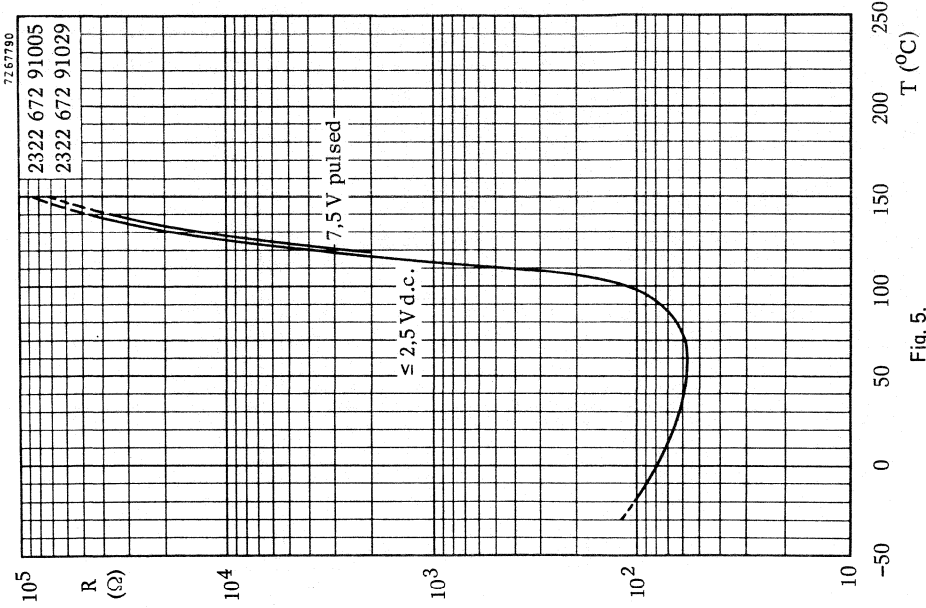

Fig. 5.

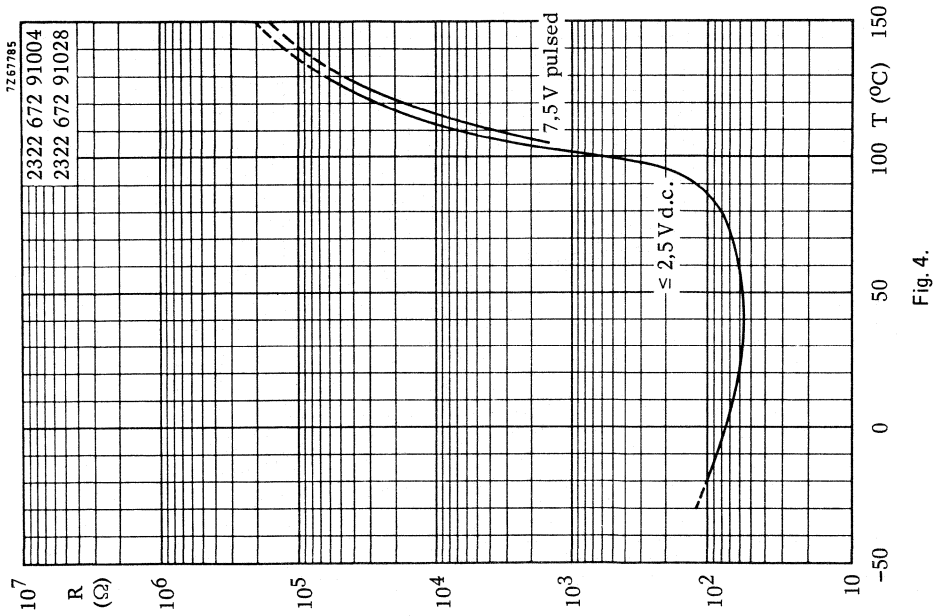

Fig. 4.

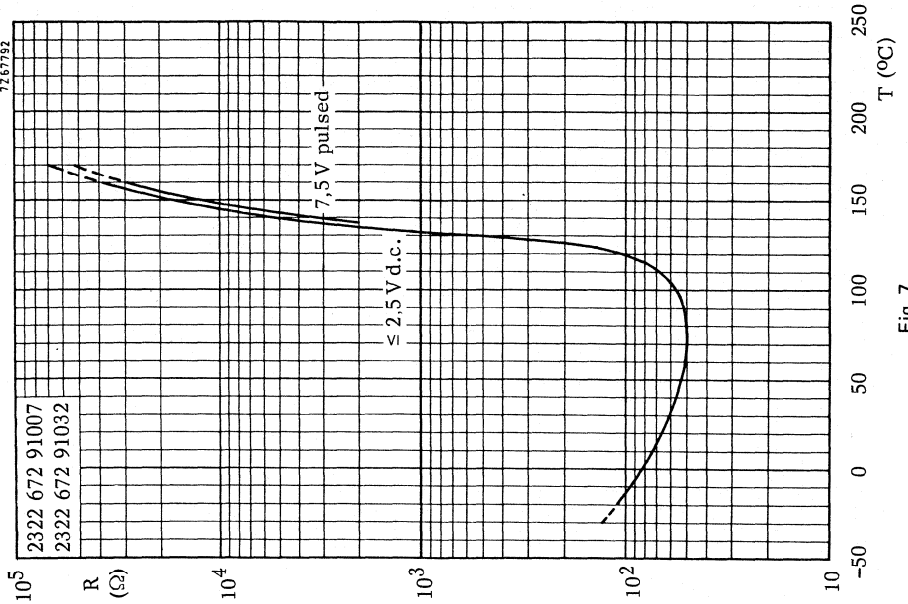

Fig. 7.

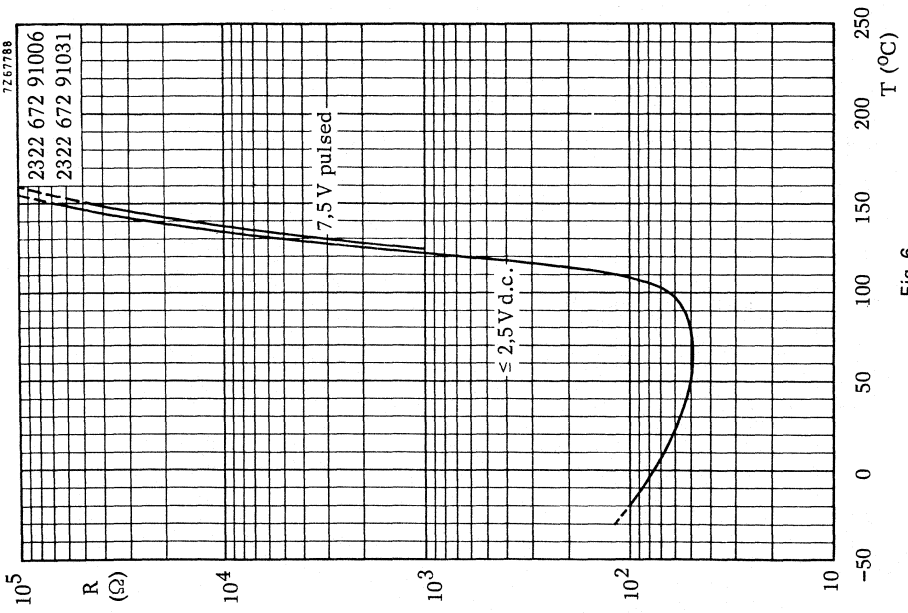

Fig. 6.

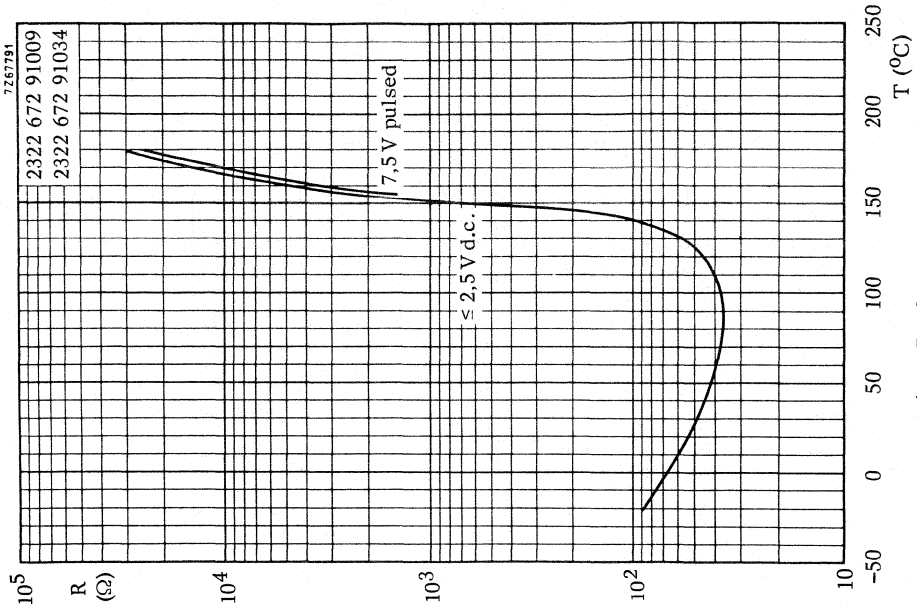

Fig. 9.

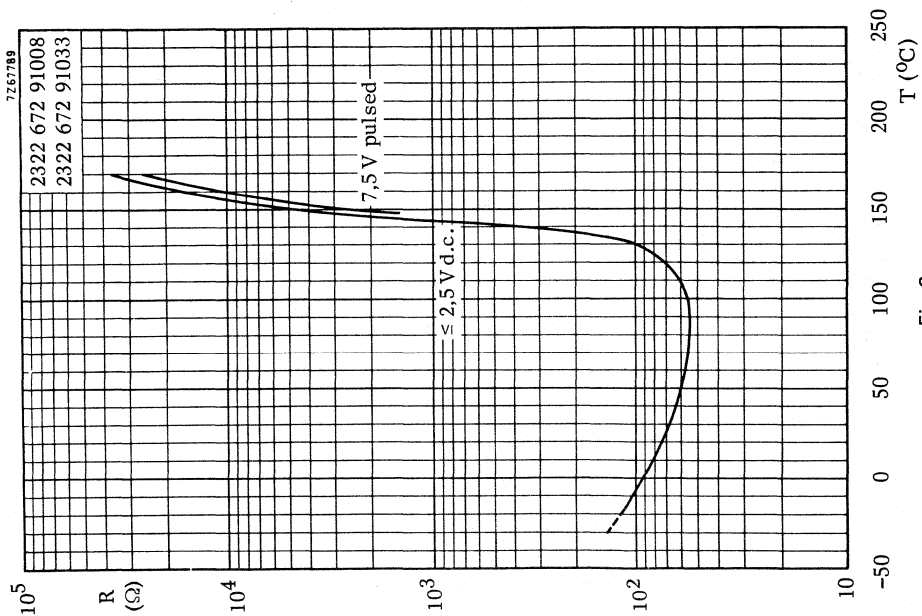

Fig. 8.

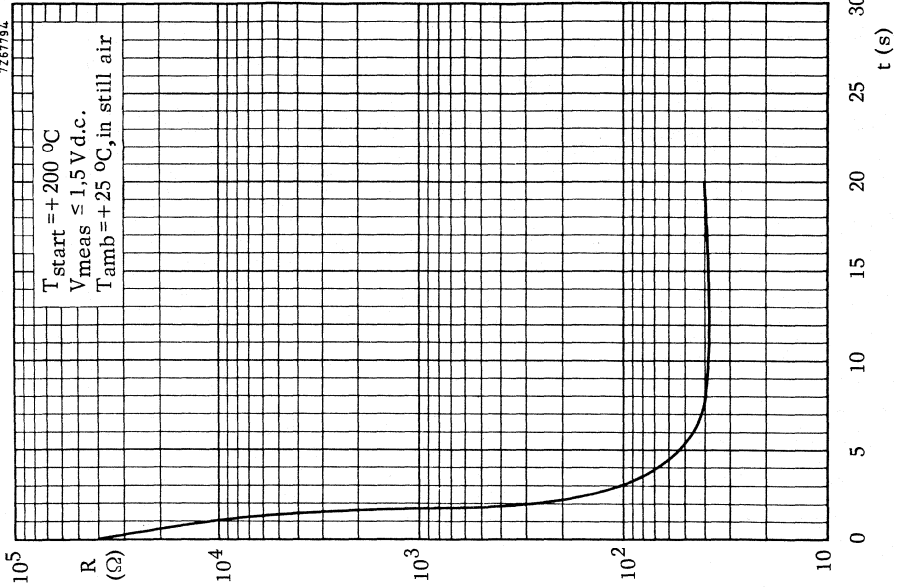

Fig. 11 Typical resistance/time (cooling) characteristic.

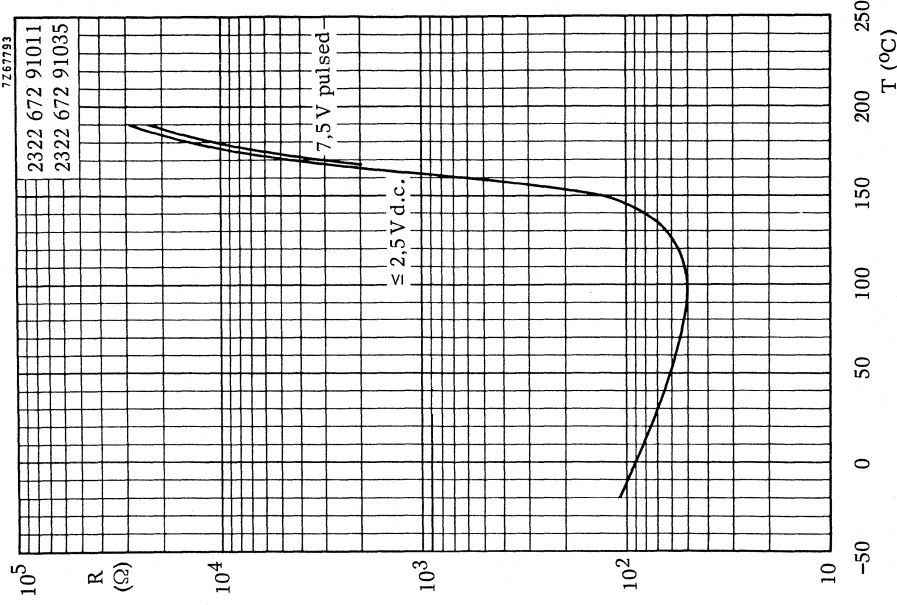

Fig. 10.

PTC THERMISTORS

for motor protection

QUICK REFERENCE DATA

Resistance value at -20 and $T_{ref} - 20$ °C	30 to 250 Ω
Resistance value at $T_{ref} + 15$ °C, $V_{pulse} = 7,5$ V	> 4000 Ω
Maximum voltage (d.c.)	15 V
Switch temperature, T_s	68 to 137 °C
Dissipation factor	≈ 7 mW/K
Operating temperature range at zero power	-20 to $T_{ref} + 30$ °C
at V_{max}	-20 to $T_{ref} + 15$ °C

APPLICATION

These thermistors have been designed for use in transistorized circuits for the protection of electric motors against overheating. They are to be built into the windings of the stator (one PTC thermistor per phase).

DESCRIPTION

The thermistors have a positive temperature coefficient. They consist of a disc with two tinned multi-strand copper wires insulated with PTFE material complying with the requirements of the ministry of aviation specification EL1930.

MECHANICAL DATA

Outlines

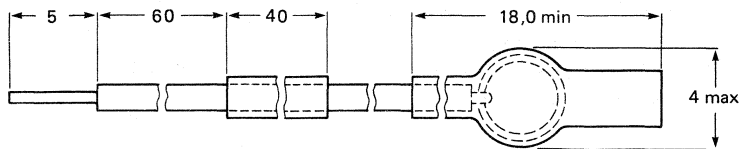
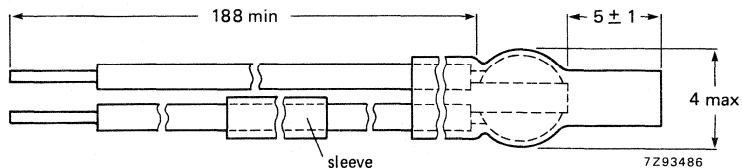

Fig. 1.



Marking The last five figures of the catalogue number are printed on the sleeve, e.g. PTC 92046.

Mass 1,6 g approximately.

Mounting In motor windings; connections to be soldered or clamped.

PACKAGING

200 thermistors in a cardboard box.

ELECTRICAL DATA

T_{ref} °C (note 1)	T_s °C	temperature coefficient %/K	voltage dependence β	balance voltage V_{dc}	catalogue number
80	68	18	0,32	19	2322 672 92045
90	75	21	0,40	27	92046
100	88	31	0,36	6,5	92047
110	99	33	0,35	17	92048
120	113	38	0,36	11	92049
130	123	27	0,38	34	92051
140	130	33	0,34	13	92052
150	137	33	0,35	20	92053

		notes
Resistance between -20 and $T_{ref} - 20$ °C	30 to 250 Ω	2
Resistance at $T_{ref} - 5$ °C	< 550 Ω	2
Resistance at $T_{ref} + 5$ °C	> 1330 Ω	
Resistance at $T_{ref} + 15$ °C, $V_{pulse} = 7,5$ V	> 4000 Ω	3
Dissipation factor	≈ 7 mW/K	4
Heat capacity	$\approx 0,1$ J/K	4
Thermal time constant	≈ 14 s	4
Response time	≤ 8 s	5
Operating temperature range at zero power at V_{max}	-20 to $+T_{ref} + 30$ °C -20 to $+T_{ref} + 15$ °C	
Maximum voltage (d.c.)	15 V	
Dielectric withstanding voltage (r.m.s.) between terminals and lead insulation	≥ 2500 V	
Insulation resistance between terminals and lead insulation	≥ 100 M Ω	

Notes

- T_{ref} is the temperature at which the thermistor has to make the protective system operative.
- Measuring voltage not exceeding 1,5 V (d.c.) to avoid internal heating.
- Measurements made without internal heating occurring.
- Measurements made with specimen in phosphor-bronze clips, in still air.
- Response time is the time in which the thermistor-body temperature rises to 63,2% of the difference between initial and final body temperature, when the thermistor is subjected to a step function change in ambient temperature.
Initial temperature: 25 °C (air).
Final temperature: $T_{ref} + 15$ °C (silicon oil MS 200/50).

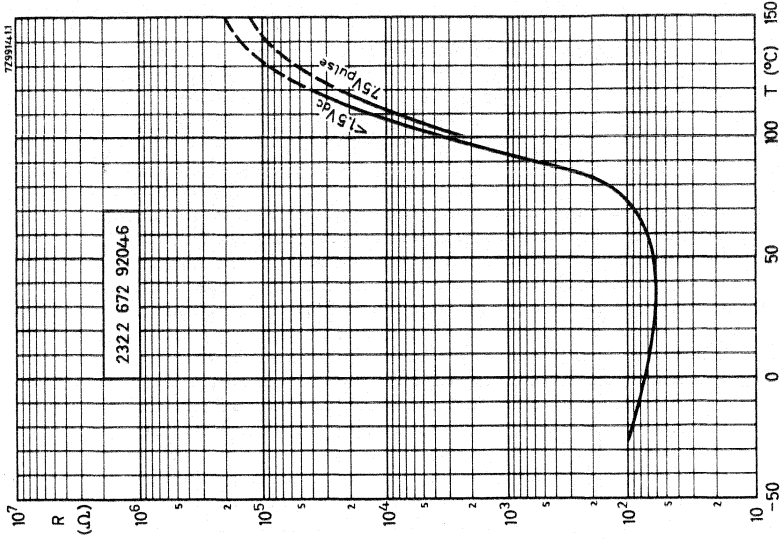

Fig. 3.

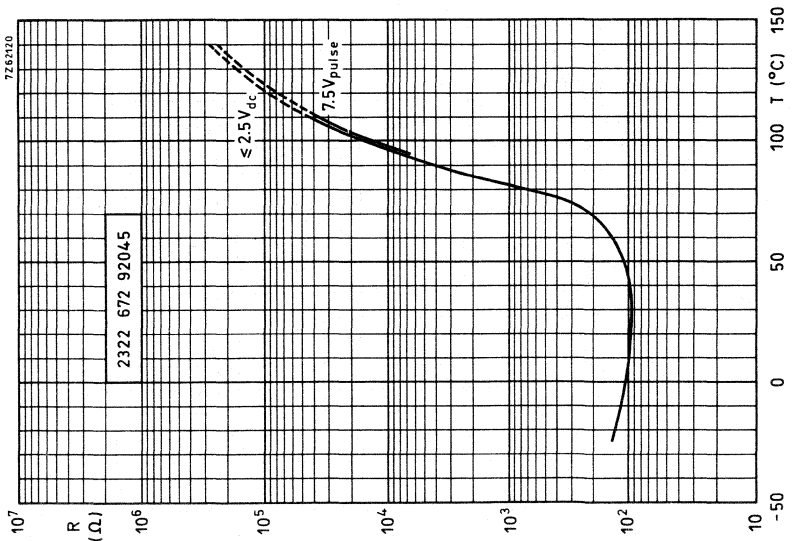

Fig. 2.

Typical resistance/temperature characteristics.

2322 672 92045
to
2322 672 92053

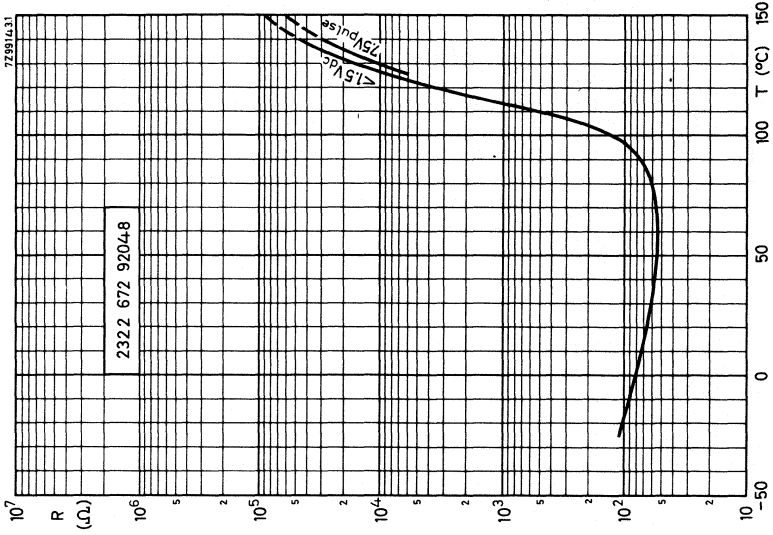

Fig. 5.

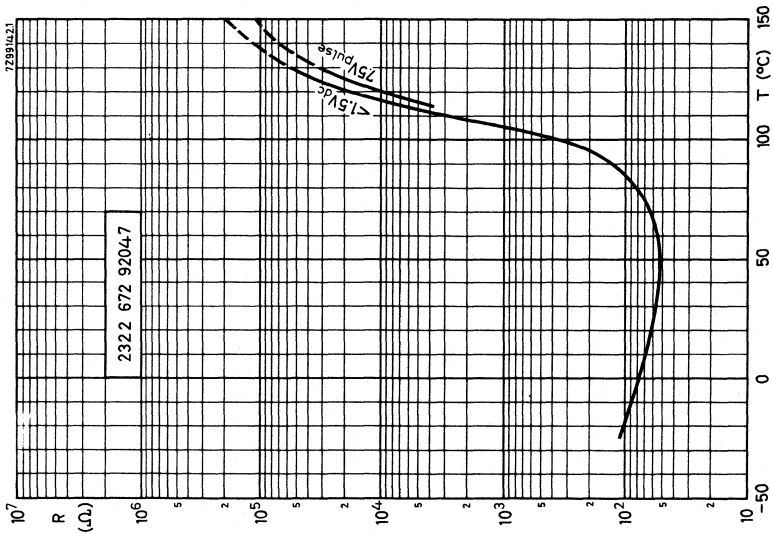

Fig. 4.

Typical resistance/temperature characteristics.

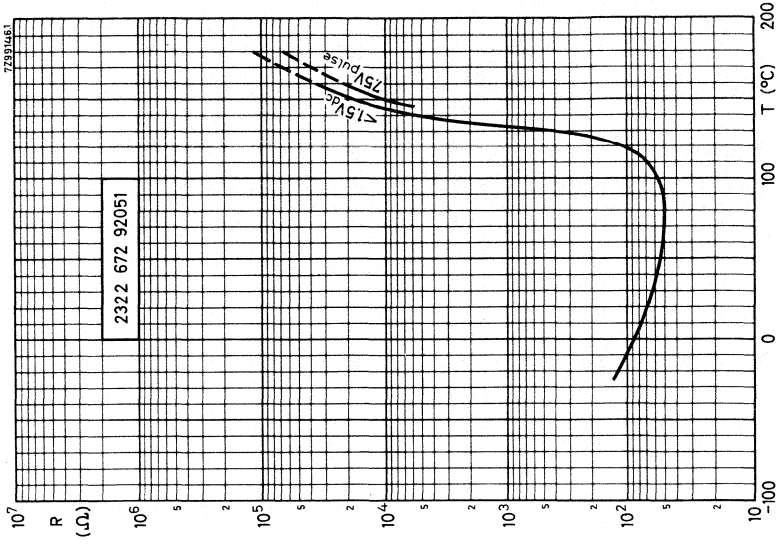

Fig. 7.

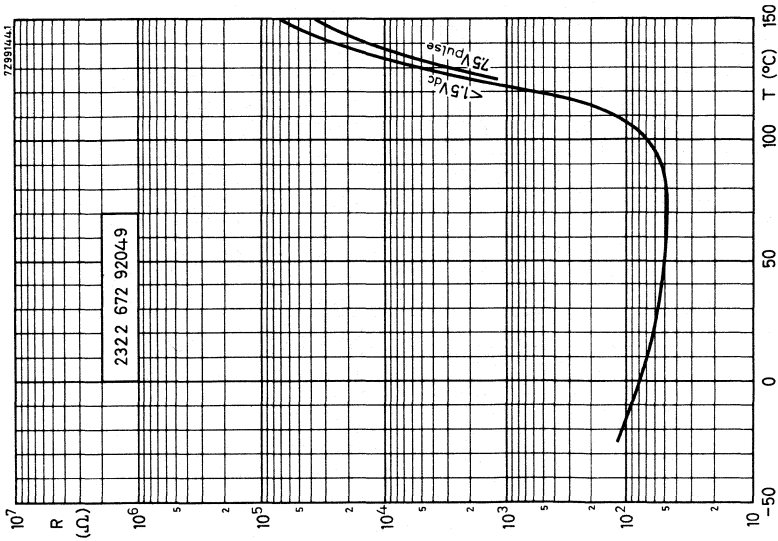

Fig. 6.

Typical resistance/temperature characteristics.

2322 672 92045
to
2322 672 92053

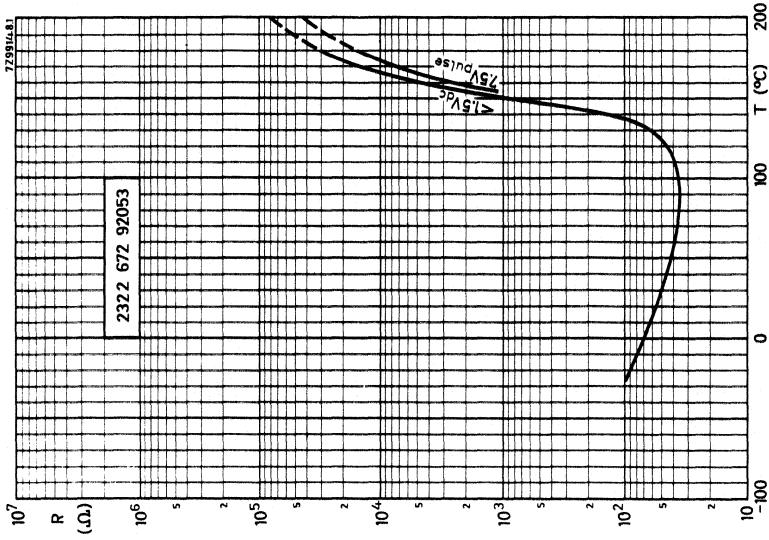

Fig. 9.

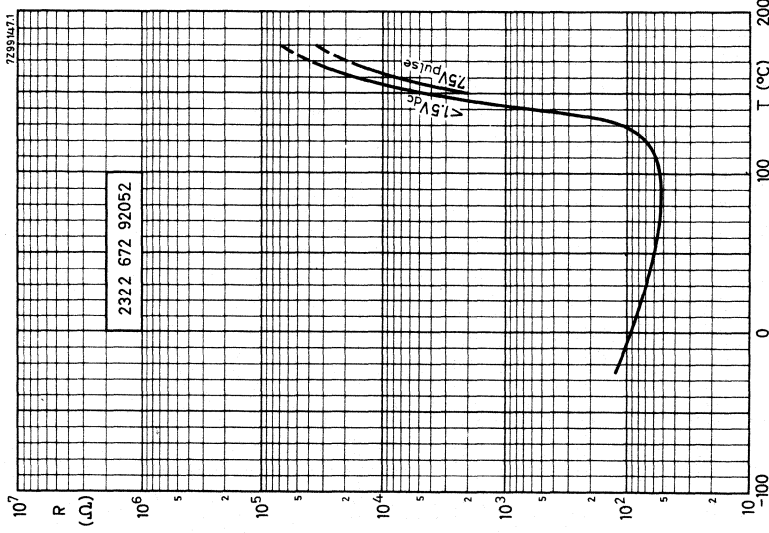

Fig. 8.

Typical resistance/temperature characteristics.

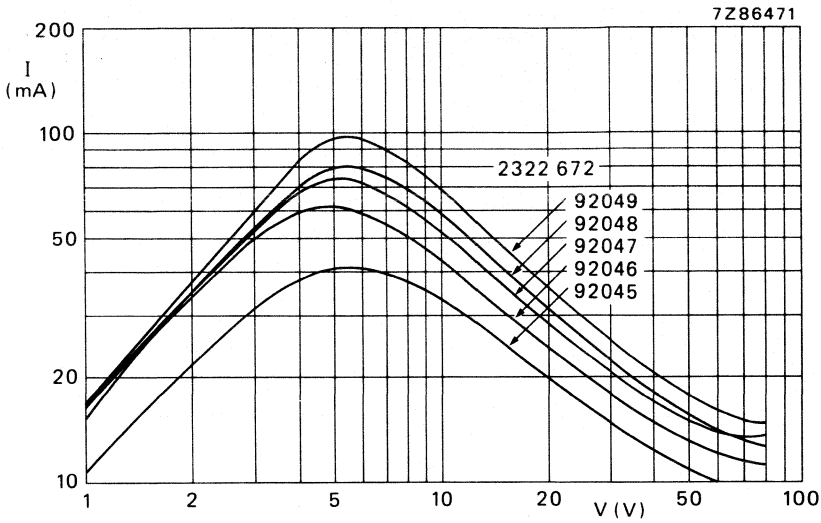

Fig. 10.

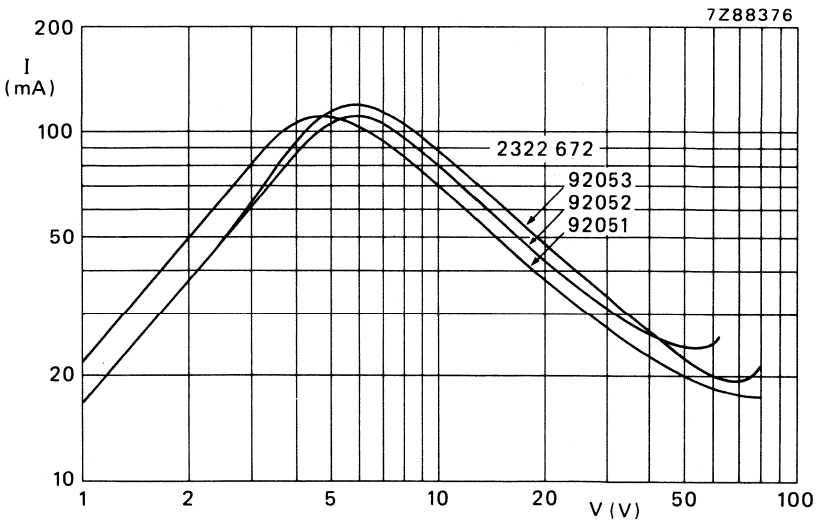

Fig. 11.

Typical voltage/current characteristics.

PTC THERMISTOR

QUICK REFERENCE DATA

Resistance value at + 25 °C	115 ± 25 Ω
Resistance value at + 155 °C, $V_{\text{pulse}} = 33 \text{ V}$	min. 15 kΩ
Switch temperature	≈ +97 °C
Temperature coefficient	min. 10%/K
Maximum voltage (d.c.)	33 V
Operating temperature range	
at zero power	-25 to + 155 °C
at maximum voltage	+ 5 to + 55 °C

APPLICATION

As current stabilizer for compensation of variations in telephone line resistance.

DESCRIPTION

Disc with positive temperature coefficient, mounted between pressure contacts to ensure a long cycle life. Provided with two silvered pins for mounting in a printed-wiring board. Plastic encapsulation.

MECHANICAL DATA

Outlines

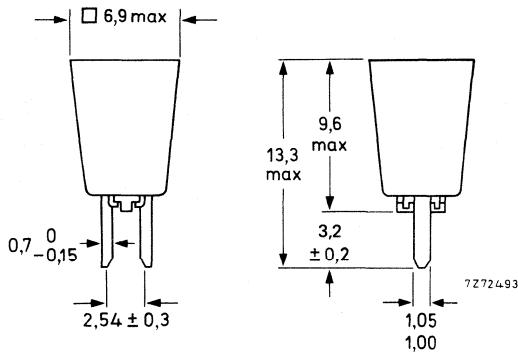

Fig. 1.

PACKAGING

5000 thermistors in a cardboard box (containing 10 foam plastic trays).

Marking

Manufacturer's identification symbol and the letters TPE, representing the model, are moulded in the top of the cap.

Mass 0,4 g approximately

Mounting to be soldered onto a printed-wiring board

Robustness of terminations

Tensile strength 10 N

Soldering

Solderability max. 240 °C, max. 4 s

Resistance to heat max. 265 °C, max. 11 s

Vibration in accordance with CCTU 01-01A fasc. 16 A severity 55 A

Impact

Free fall 1000 mm

Inflammability unflammable

ELECTRICAL DATA

The values in the table without further indication are approximate values.

Resistance

at +25 °C

115 ± 25 Ω

at +97 °C

max. 600 Ω

at +155 °C, $V_{\text{pulse}} = 33 \text{ V}$

min. 15 000 Ω

Switch temperature

+97 °C

Temperature coefficient

min. +10%/K

Operating temperature range

at zero power

-25 to +155 °C

at maximum voltage

+5 to +55 °C

Voltage dependence at +155 °C

0,29

Maximum voltage (d.c.)

33 V

Maximum dielectric withstanding voltage (r.m.s.) between terminals and capsule

500 V

Insulation resistance between terminals and capsule at 100 V d.c.

min. 10 MΩ

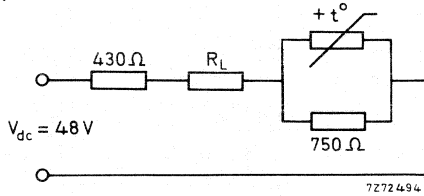

Fig. 2 Line resistance (R_L) compensation.

Initial current of +5 °C and $R_L = 0$	min. 75 mA
	max. 95 mA
Current after 10 s at +5 °C and $R_L = 0$	max. 60 mA
Initial current at +55 °C and $R_L = 0$	min. 85 mA
	max. 105 mA
Current after 10 s at +5 °C and $R_L = 0$	max. 55 mA

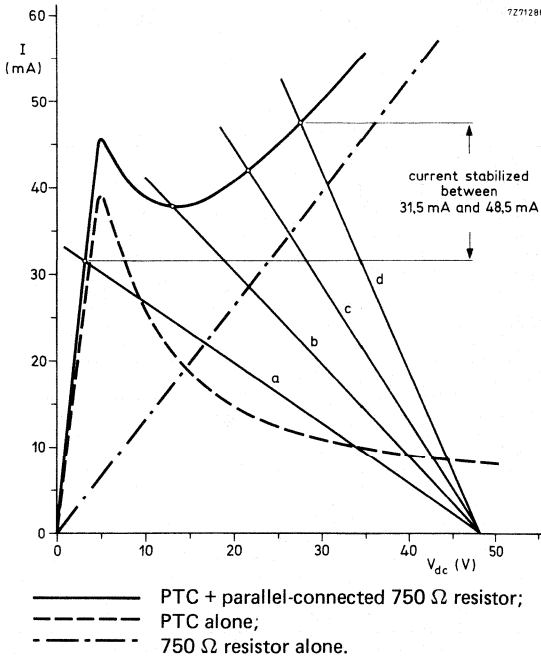

Fig. 3 (a) $R_L = 1000 \Omega$; (c) $R_L = 200 \Omega$;
 (b) $R_L = 500 \Omega$; (d) $R_L = 0 \Omega$.

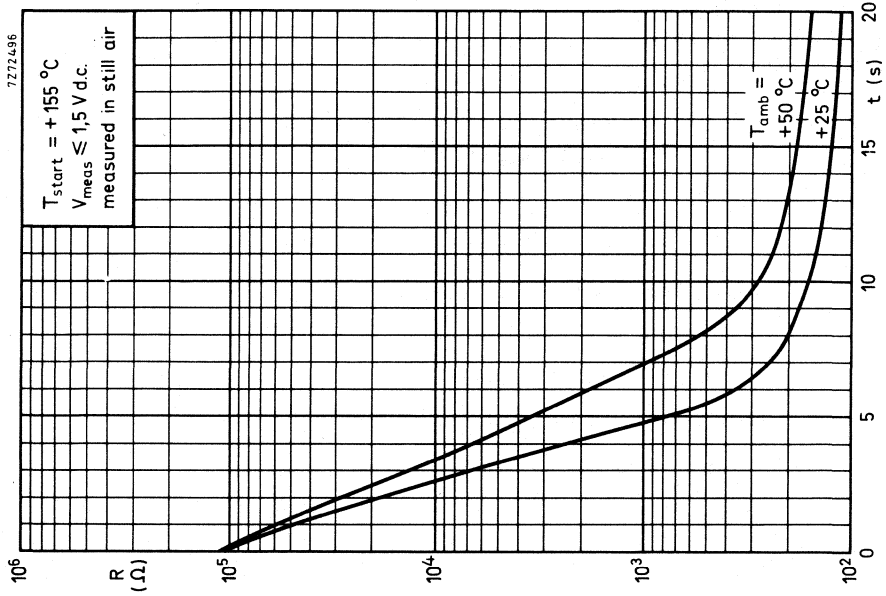

Fig. 5 Typical resistance/time (cooling) characteristics.

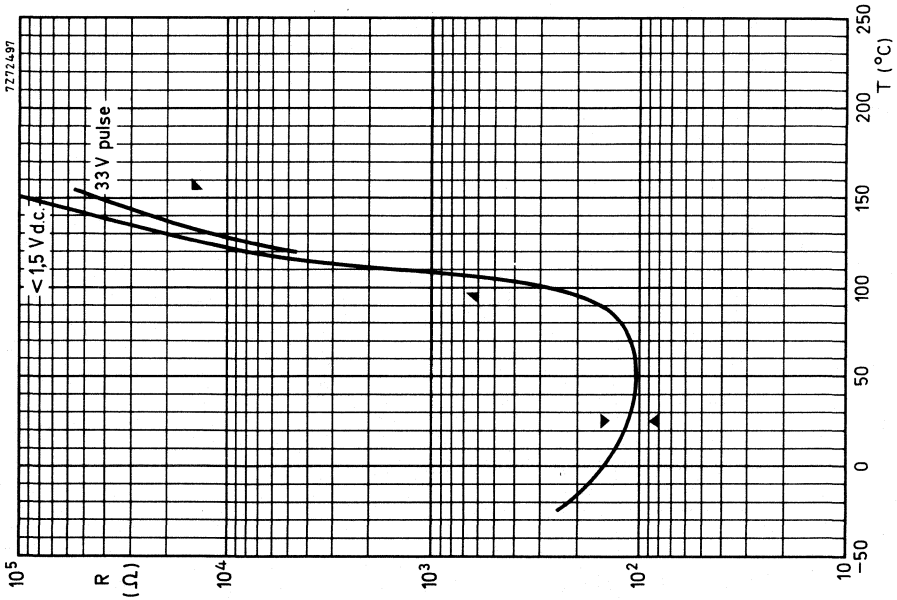

Fig. 4 Typical resistance/temperature characteristics.

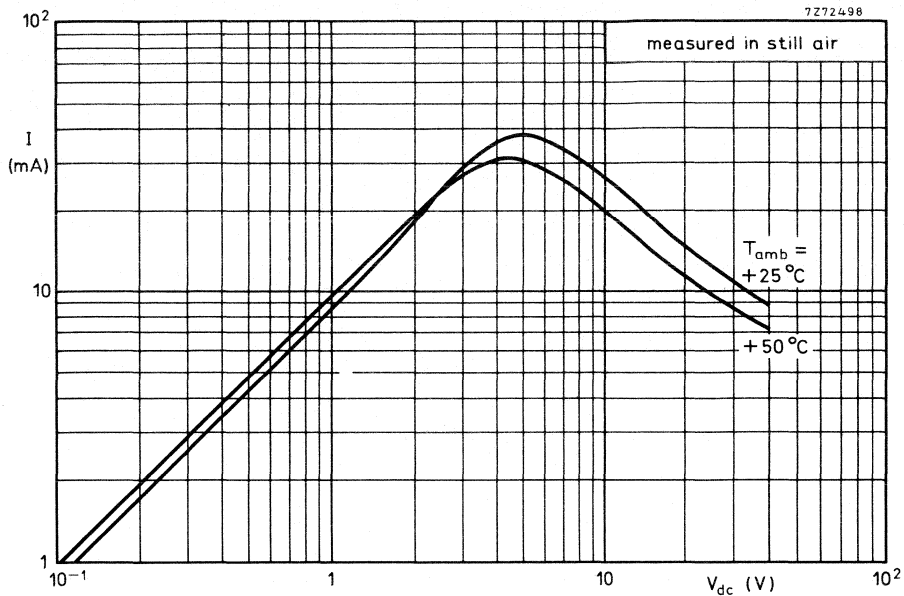

Fig. 6 Typical voltage/current characteristics.

Note:

Figs 5, 6 and 7 are measured with the PTC mounted on a printed-wiring board.

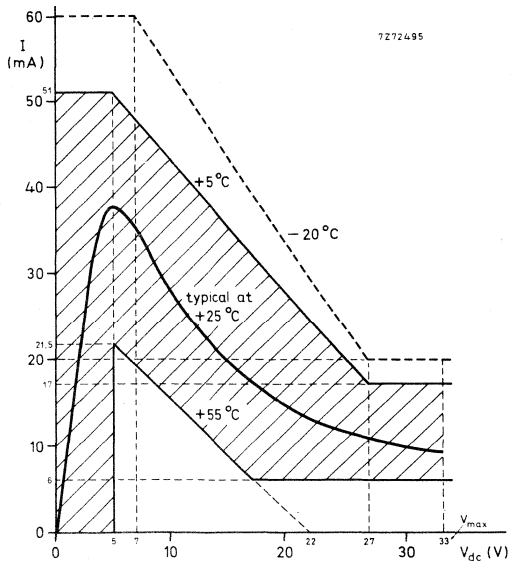

Fig. 7 Area of current/voltage characteristics.

DEVELOPMENT DATA

This data sheet contains advance information and specifications are subject to change without notice.

2322 680 00001

PTC THERMISTORS FOR HEATING

QUICK REFERENCE DATA

Voltage range, r.m.s., 50 or 60 Hz	100 to 265 V
Temperature after 20 min at 220 V r.m.s.	160 ± 12 °C
Maximum time to reach 130 °C at 220 V r.m.s.	5 min
Maximum inrush power at 265 V r.m.s.	1 kW
Operating temperature range	
at zero power	-25 to + 85 °C
at maximum voltage	0 to 55 °C

APPLICATION

As heating element for general use.

DESCRIPTION

Encapsulated single insulated thermistor with positive temperature coefficient and provided with two single-core insulated silver plated copper wires.

MECHANICAL DATA

Outlines

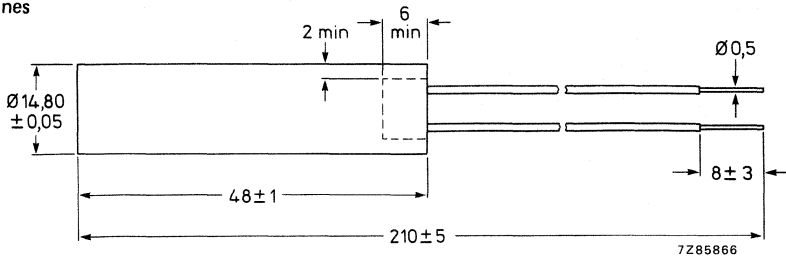

Fig. 1.

PACKAGING

500 thermistors in a cardboard box.

A label on the cardboard box is provided with following details:

Manufacturer's name

Voltage range

Operating power after 20 min – UL emblem

Group name

Catalogue number

Quantity, reference, manufacturing date (year – month)

Marking	The thermistors are tan coloured; the connecting leads are blue.
Connections	PTFE wire according to Thermax wire 24-XTO-124 UL style 1180.
Mass	20 g approximately
Mounting	In any position by soldering or clamping. Suitable for mounting in a tube with a diameter of $14,86 + 0,05$ mm.
Robustness of terminations	
Tensile strength	10 N
Bending	5 N
Solderability	max. 240 °C, max. 6 s
Impact	
Free fall	1000 mm
Inflammability	uninflammable, in accordance with IEC publication 695-2-2 of 1980.

ELECTRICAL DATA

Voltage range, r.m.s., 50 or 60 Hz	100 to 265 V
Temperature after 20 min at 220 V r.m.s.	160 ± 12 °C
Maximum time to reach 130 °C at 220 V r.m.s.	5 min
Maximum inrush power at 265 V r.m.s.	1 kW
Operating power after 20 min at 220 V r.m.s.	~ 13 W
Minimum dielectric withstanding voltage, r.m.s.	4 kV
Operating temperature range	
at zero power	-25 to + 85 °C
at maximum voltage	0 to + 55 °C

DEVELOPMENT DATA

This data sheet contains advance information and specifications are subject to change without notice.

2322 680 03001

PTC THERMISTORS FOR HEATING

QUICK REFERENCE DATA

Voltage range, r.m.s., 50 or 60 Hz	100 to 265 V
Temperature after 20 min at 220 V r.m.s.	160 ± 12 °C
Maximum time to reach 130 °C at 220 V r.m.s.	5 min
Maximum inrush power at 265 V r.m.s.	1 kW
Operating temperature range	
at zero power	-25 to + 85 °C
at maximum voltage	0 to + 55 °C

APPLICATION

As heating element for general use.

DESCRIPTION

Encapsulated single insulated thermistor with positive temperature coefficient and provided with two single-core insulated silver plated copper wires.

MECHANICAL DATA

Outlines

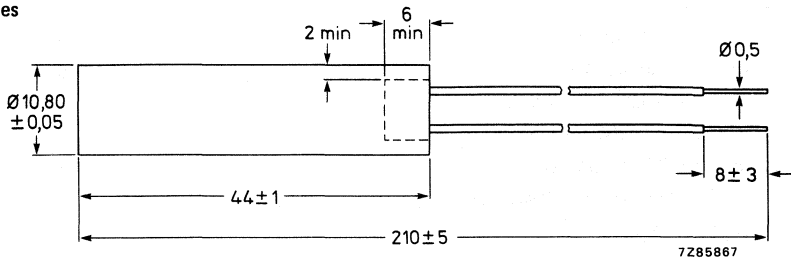

Fig. 1.

PACKAGING

1000 thermistors in a cardboard box.

A label on the cardboard box is provided with the following details:

Manufacturer's name

Voltage range

Operating power after 20 min – UL emblem

Group name

Catalogue number

Quantity, reference, manufacturing date (year – month)

Marking	The thermistors are tan coloured. the connecting leads are white
Connections	PTFE wire according to Thermax wire 24-XTO-124 UL style 1180.
Mass	10 g approximately
Mounting	In any position by soldering or clamping. Suitable for mounting in a tube with a diameter of $10,86 \pm 0,05$ mm.
Robustness of terminations	
Tensile strength	10 N
Bending	5 N
Solderability	max. 240 °C, max. 6 s
Impact	
Free fall	1000 mm
Inflammability	uninflammable, in accordance with IEC publication 695-2-2 of 1980

ELECTRICAL DATA

Voltage range, r.m.s., 50 or 60 Hz	100 to 265 V
Temperature after 20 min. at 220 V r.m.s.	160 ± 12 °C
Maximum time to reach 130 °C at 220 V r.m.s.	5 min
Maximum inrush power at 265 V r.m.s.	1 kW
Operating power after 20 min. at 220 V r.m.s.	~ 10 W
Minimum dielectric withstanding voltage, r.m.s.	4 kV
Operating temperature range	
at zero power	-25 to + 85 °C
at maximum voltage	0 to + 55 °C

DEVELOPMENT DATA

This data sheet contains advance information and specifications are subject to change without notice.

2322 680 04001

PTC THERMISTORS FOR HEATING

QUICK REFERENCE DATA

Voltage range, r.m.s., 50 or 60 Hz	100 to 265 V
Temperature after 20 min at 220 V r.m.s.	215 ± 12 °C
Maximum time to reach 170 °C at 220 V r.m.s.	5 min
Maximum inrush power at 265 V r.m.s.	1 kW
Operating temperature range	
at zero power	-25 to + 85 °C
at maximum voltage	0 to + 55 °C

APPLICATION

As heating element for general use.

DESCRIPTION

Encapsulated single insulated thermistor with positive temperature coefficient and provided with two single-core insulated silver plated copper wires.

MECHANICAL DATA

Outlines

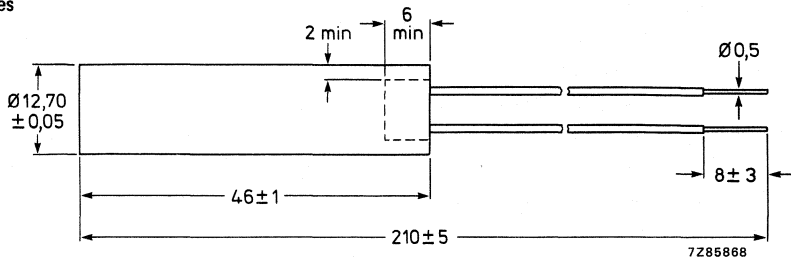

Fig. 1.

PACKAGING

1000 thermistors in a cardboard box.

A label on the cardboard box is provided with the following details:

Manufacturer's name

Voltage range

Operating power after 20 min – UL emblem

Group name

Catalogue number

Quantity, reference, manufacturing date (year – month)

Marking	The thermistors are red coloured; the connecting leads are red.
Connections	PTFE wire according to Thermax wire 24-XTO-124 UL style 1180.
Mass	15 g approximately
Mounting	In any position by soldering or clamping. Suitable for mounting in a tube with a diameter of $12,76 + 0,05$ mm.
Robustness of terminations	
Tensile strength	10 N
Bending	5 N
Solderability	max. 240 °C, max. 6 s
Impact	
Free fall	1000 mm
Inflammability	uninflammability, in accordance with IEC publication 695-2-2 of 1980

ELECTRICAL DATA

Voltage range, r.m.s., 50 or 60 Hz	100 to 265 V
Temperature after 20 min. at 220 V r.m.s.	215 ± 12 °C
Maximum time to reach 170 °C at 220 V r.m.s.	5 min
Maximum inrush power at 265 V r.m.s.	1 kW
Operating power after 20 min. at 220 V r.m.s.	~ 18 W
Minimum dielectric withstanding voltage, r.m.s.	4 kV
Operating temperature range	
at zero power	-25 to + 85 °C
at maximum voltage	0 to + 55 °C

DEVELOPMENT DATA

This data sheet contains advance information and specifications are subject to change without notice.

2322 680 04002

PTC THERMISTORS FOR HEATING

QUICK REFERENCE DATA

Voltage range, r.m.s., 50 or 60 Hz	100 to 145 V
Temperature after 20 min at 120 V r.m.s.	215 ± 12 °C
Maximum time to reach 170 °C at 120 V r.m.s.	5 min
Maximum inrush power at 145 r.m.s.	1 kW
Operating temperature range	
at zero power	-25 to + 85 °C
at maximum voltage	0 to + 55 °C

APPLICATION

As heating element for general use.

DESCRIPTION

Encapsulated single insulated thermistor with positive temperature coefficient and provided with two single-core insulated silver plated copper wires.

MECHANICAL DATA

Outlines

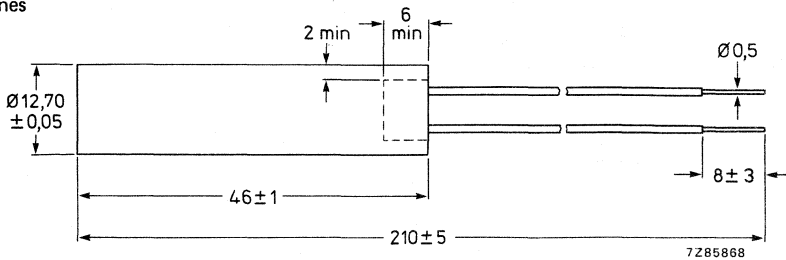

Fig. 1.

PACKAGING

1000 thermistors in a cardboard box.

A label on the cardboard box is provided with the following details:

Manufacturer's name

Voltage range

Operating power after 20 min – UL emblem

Group name

Catalogue number

Quantity, reference, manufacturing date (year – month)

Marking The thermistors are red coloured; the connecting leads are red and black.

Connections PTFE wire according to Thermax wire 24-XTO-124 UL style 1180.

Mass 15 g approximately

Mounting In any position by soldering or clamping. Suitable for mounting in a tube with a diameter of 12,76 + 0,05 mm.

Robustness of terminations

Tensile strength 10 N

Bending 5 N

Solderability max. 240 °C, max. 6 s

Impact

Free fall 1000 mm

Inflammability unflammable, in accordance with IEC publication 695-2-2 of 1980

ELECTRICAL DATA

Voltage range, r.m.s., 50 or 60 Hz	100 to 145 V
Temperature after 20 min. at 120 V r.m.s.	215 ± 12 °C
Maximum time to reach 170 °C at 120 V r.m.s.	5 min
Maximum inrush power at 145 V r.m.s.	1 kW
Operating power after 20 min. at 120 V r.m.s.	~ 18 W
Minimum dielectric withstanding voltage, r.m.s.	4 kV
Operating temperature range	
at zero power	-25 to + 85 °C
at maximum voltage	0 to + 55 °C

DEVELOPMENT DATA

This data sheet contains advance information and specifications are subject to change without notice.

2322 680 04003

PTC THERMISTORS FOR HEATING

QUICK REFERENCE DATA

Voltage range, r.m.s., 50 or 60 Hz	100 to 265 V
Temperature after 20 min at 220 V r.m.s.	160 ± 12 °C
Maximum time to reach 130 °C at 220 V r.m.s.	5 min
Maximum inrush power at 265 V r.m.s.	1 kW
Operating temperature range	
at zero power	-25 to + 85 °C
at maximum voltage	0 to + 55 °C

APPLICATION

As heating element for general use.

DESCRIPTION

Encapsulated single insulated thermistor with positive temperature coefficient and provided with two single-core insulated silver plated copper wires.

MECHANICAL DATA

Outlines

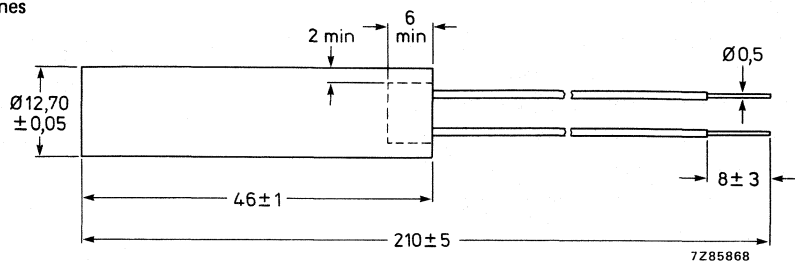

Fig. 1.

PACKAGING

1000 thermistors in a cardboard box.

A label on the cardboard box is provided with the following details:

Manufacturer's name

Voltage range

Operating power after 20 min – UL emblem

Group name

Catalogue number

Quantity, reference, manufacturing date (year – month)

Marking	The thermistors are tan coloured; the connecting leads are red.
Connections	PTFE wire according to Thermax wire 24-XTO-124 UL style 1180.
Mass	15 g approximately
Mounting	In any position by soldering or clamping. Suitable for mounting in a tube with a diameter of $12,76 + 0,05$ mm.
Robustness of terminations	
Tensile strength	10 N
Bending	5 N
Solderability	max. 240 °C, max. 6 s
Impact	
Free fall	1000 mm
Inflammability	uninflammable, in accordance with IEC publication 695-2-2 of 1980

ELECTRICAL DATA

Voltage range, r.m.s., 50 or 60 Hz	100 to 265 V
Temperature after 20 min. at 220 V r.m.s.	160 ± 12 °C
Maximum time to reach 130 °C at 220 V r.m.s.	5 min
Maximum inrush power at 265 V r.m.s.	1 kW
Operating power after 20 min. at 220 V r.m.s.	~ 13 W
Minimum dielectric withstanding voltage, r.m.s.	4 kV
Operating temperature range	
at zero power	-25 to + 85 °C
at maximum voltage	0 to + 55 °C

DEVELOPMENT DATA

This data sheet contains advance information and specifications are subject to change without notice.

2322 680 04004

PTC THERMISTORS FOR HEATING

QUICK REFERENCE DATA

Voltage range, r.m.s., 50 or 60 Hz	100 to 145 V
Temperature after 20 min at 120 V r.m.s.	160 ± 12 °C
Maximum time to reach 130 °C at 120 V r.m.s.	5 min
Maximum inrush power at 145 V r.m.s.	1 kW
Operating temperature range	
at zero power	-25 to +85 °C
at maximum voltage	0 to +55 °C

APPLICATION

As heating element for general use.

DESCRIPTION

Encapsulated single insulated thermistor with positive temperature coefficient and provided with two single-core insulated silver plated copper wires.

MECHANICAL DATA

Outlines

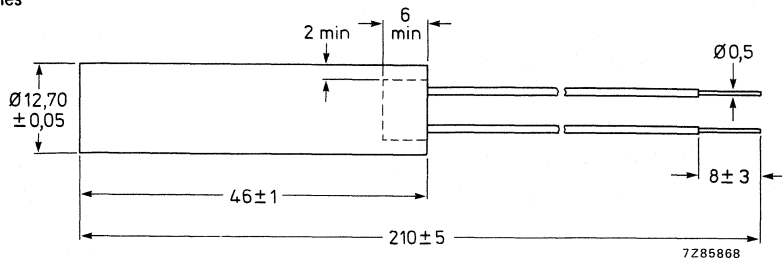

Fig. 1.

PACKAGING

1000 thermistors in a cardboard box.

A label on the cardboard box is provided with the following details:

Manufacturer's name

Voltage range

Operating power after 20 min – UL emblem

Group name

Catalogue number

Quantity, reference, manufacturing date (year – month)

Marking The thermistors are tan coloured; the connecting leads are red and black.

Connections PTFE wire according to Thermax wire 24-XTO-124 UL style 1180.

Mass 15 g approximately

Mounting In any position by soldering or clamping. Suitable for mounting in a tube with a diameter of $12,76 + 0,05$ mm.

Robustness of terminations

Tensile strength 10 N

Bending 5 N

Solderability max. 240 °C, max. 6 s

Impact

Free fall 1000 mm

Inflammability unflammable, in accordance with IEC publication 695-2-2 of 1980

ELECTRICAL DATA

Voltage range, r.m.s., 50 or 60 Hz	100 to 145 V
Temperature after 20 min. at 120 V r.m.s.	160 ± 12 °C
Maximum time to reach 130 °C at 120 V r.m.s.	5 min
Maximum inrush power at 145 V r.m.s.	1 kW
Operating power after 20 min. at 120 V r.m.s.	~ 13 W
Minimum dielectric withstanding voltage, r.m.s.	4 kV
Operating temperature range	
at zero power	-25 to + 85 °C
at maximum voltage	0 to + 55 °C

PTC HEATING ELEMENT

QUICK REFERENCE DATA

Voltage range (r.m.s.)	100 to 265 V
Maximum inrush power at 265 V	1 kW
Operating power at 220 V after 20 min	19 W
Time to reach +180 °C at 220 V	< 5 min
Operating temperature range at zero power	-25 to +85 °C
at maximum voltage	0 to +55 °C

APPLICATION

Designed for applications that require high initial dissipation followed by moderate continuous dissipation, such as hot melt glue guns.

DESCRIPTION

Insulated heating element consisting of a PTC thermistor moulded in a silicone rubber tube with two insulated silver plated copper wires.

MECHANICAL DATA

Outlines

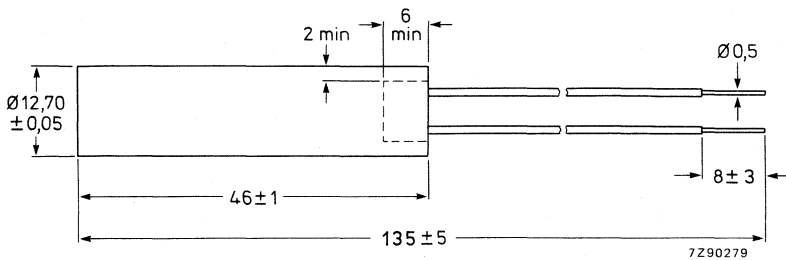

Fig. 1.

Marking	Connecting leads: red (twice)
Mounting	In any position by soldering or clamping
Robustness of terminations	
Tensile strength	10 N
Bending	5 N
Soldering	
Solderability	max. 240 °C, max. 6 s
Impact	
Free fall	1000 mm

PACKAGING

600 thermistors in a cardboard box

ELECTRICAL DATAMeasurements made in still air at an ambient temperature of $+23 \pm 1$ °C

Voltage range (r.m.s.)	100 to 265 V
Maximum inrush power at 265 V	1 kW
Operating power at 220 V, after 20 min	19 W approx.
Time to reach +180 °C at 220 V	< 5 minutes
Temperature on standard test mounting after 20 min at 220 V	220 ± 10 °C
Operating temperature range	
at zero power	-25 to +85 °C
at maximum voltage	0 to +55 °C

DEVELOPMENT DATA

This data sheet contains advance information and specifications are subject to change without notice.

PTC
680 93 SERIES

PTC THERMISTORS

heating elements

QUICK REFERENCE DATA

Resistance at 25 °C and 50 V pulse	300 Ω to 9,9 kΩ
Switch temperature	115 to 245 °C
Maximum voltage, r.m.s.	145 and 265 V
Operating temperature range at maximum voltage	0 to 55 °C

APPLICATION

Ceramic heating elements for low power domestic and industrial applications and in thermally delayed switches which require the temperature to be stabilized.

DESCRIPTION

These thermistors have a positive temperature coefficient. They consist of a parallelepiped with two non-solderable electrical contacts.

MECHANICAL DATA

Outlines

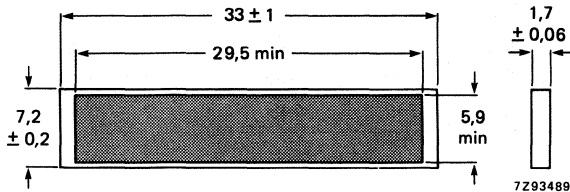

Fig. 1.

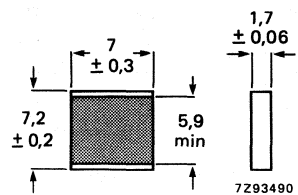

Fig. 2.

Flatness	: 50 μm max
Marking	: none
Mass	: see Table
Mounting	: in any position by clamping
Impact	: free fall 200 mm
Inflammability	: unflammable

PTC 680 93 SERIES

ELECTRICAL DATA

Unless otherwise specified, measured according to IEC publication 738-1 of 1982

Table *

catalogue number	resistance at 50 V _{pulse}			T _S approx.	maximum voltage r.m.s. V	dimensions see Fig.	mass approx. g
	25 °C	T _S	T _S + 30 °C				
	± 35%	max.	min.				
2322 680 followed by	Ω	Ω	Ω	°C			
93021	850	2000	5000	115	265	1	2,25
93022	220	500	1250	145	265	1	2,25
93023	850	1500	4000	170	265	1	2,25
93024	300	300	750	200	265	1	2,25
93025	1700	850	2000	230	265	1	2,25
93026	2300	700	1750	245	265	1	2,25
93027	400	750	2000	170	145	1	2,25
93028	680	350	800	240	145	1	2,25
93029	3650	8600	21500	115	265	2	0,46
93031	950	2200	5400	145	265	2	0,46
93032	3650	8600	21500	170	265	2	0,46
93033	1300	1300	3250	200	265	2	0,46
93034	7300	3600	8600	230	265	2	0,46
93035	9900	3000	4300	245	265	2	0,46
93036	1720	3250	8600	170	145	2	0,46
93037	2900	1500	3450	240	145	2	0,46

* T_S = switch temperature

PACKAGING

Types 2322 680 93021 ... 29 : 420 thermistors in a cardboard box

Types 2322 680 93031 ... 37 : 1500 thermistors in a cardboard box

DEVELOPMENT DATA

This data sheet contains advance information and specifications are subject to change without notice.

2322 66. 0...1

2322 66. 1...1

PTC THERMISTORS

for overload protection

QUICK REFERENCE DATA

Resistance at 25 °C	1,8 to 90 Ω
Switch temperature	approx. 120 °C
Maximum d.c. voltage	56 V
Trip current at 10 °C	112 to 1360 mA
Operating temperature range at V_{max}	0 to + 55 °C

APPLICATION

Overload protection, for use in electric and electronic equipment such as electric motors, transformers and semiconductor circuits.

DESCRIPTION

These thermistors have a positive temperature coefficient. They consist of a disc with two tinned brass wires, see Fig. 1a. Leadless types having metallized sides for soldering by the user are also available, see Fig. 1b.

MECHANICAL DATA

Outlines

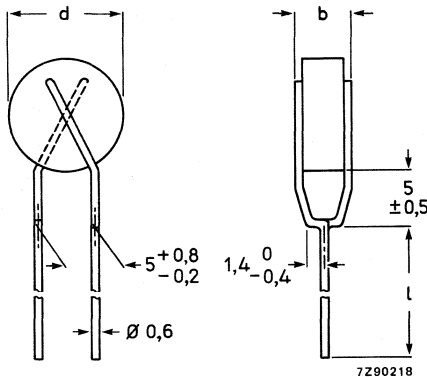

Fig. 1a.

Fig. 1b.

For dimensions b , d , l and t see Table 1.

Marking	None
Mass	See Table 1
Mounting	In any position by soldering
Robustness of terminations	
Tensile strength	10 N
Bending	5 N

Soldering

Solderability	max. 240 °C, max. 4 s
Resistance to heat	max. 265 °C, max. 11 s

→ When soldering leadless types it is recommended to use a flux containing colofonium and aethyl alcohol only and to pre-heat the discs to approx. 100 °C in order to avoid thermal shocks which might damage the thermistors.

Impact	200 mm free fall
Inflammability	Uninflammable

Packaging

Cardboard boxes containing following items for:

2322 660 1: 500	2322 662 1: 100
2322 661 1: 250	2322 663 1: 100
2322 662 . 1811: 200	2322 663 1: 100

ELECTRICAL DATA

Unless otherwise specified measured according to IEC publication 738-1 (1982).

Maximum current for not tripping at 55 °C (measuring time 5 minutes)	I_{nt}	See Table 1
Minimum current for tripping after 5 minutes at 10 °C	$I_t = 2 \times I_{nt}$	See Table 1
Resistance at + 25 °C	R_{25}	See Table 1
Switch temperature	T_s	≈ 120 °C
Maximum admissible current at 0 °C	I_{max}	See Table 1
Maximum residual current at 56 V (d.c.) at 10 °C	$I_{res max}$	See Table 1
Maximum d.c. voltage with a series resistor		56 V
Series resistor	R_s	See Table 1
Maximum d.c. voltage without series resistor		18 V
Dissipation factor at T_s	D	See Table 1
Heat capacity	H	See Table 1
Operating temperature range at zero power		-25 to + 125 °C
at maximum voltage		0 to + 55 °C

Table 1

catalogue number	I_{nt} at 55 °C mA	I_t at 10 °C mA	R_{25} approx. Ω	I_{max} at 0 °C mA	$I_{res max}$ at 10 °C mA	$R_s \pm 5\%$ Ω	D approx. mW/K	H approx. J/K	d mm	b max. mm	l ± 3 mm	t max. mm	mass approx. g
2322 660 .5691	56	112	90	460	30	56	6	0,08	4,5	4	20	2,8	0,35
660 .6891	68	136	60	600	30	51	6	0,08	4,5	4	20	2,8	0,35
660 .8291	82	164	42	750	30	43	6	0,08	4,5	4	20	2,8	0,35
661 .1011	100	200	32	950	35	36	7	0,15	6,5	4	20	2,8	0,47
661 .1211	120	240	22	1300	35	27	7	0,15	6,5	4	20	2,8	0,47
661 .1511	150	300	18	1600	40	22	7,5	0,16	8,0	4	20	2,8	0,65
662 .1811	180	360	12,5	2200	45	16	8	0,42	10,0	4,5	20	3,3	1,05
662 .2211	220	440	9	2900	50	13	9	0,55	12,0	4,5	20	3,3	1,43
662 .2711	270	540	6,5	4000	50	10	9	0,55	12,0	4,5	20	3,3	1,43
663 .3311	330	660	4,3	6300	60	5,6	10	0,83	13,0	5	20	3,8	2,15
663 .3911	390	780	3,8	7300	70	5,1	12	1,24	16,0	5	20	3,8	2,90
663 .4711	470	940	2,6	12000	70	2,7	12	1,24	16,0	5	20	3,8	2,90
664 .5611	560	1120	2,2	14000	100	2,4	16	2,34	20,0	6	16	4,8	5,30
664 .6811	680	1360	1,6	18000	100	2,0	16	2,34	20,0	6	16	4,8	5,30

For leadless types replace the dot in the catalogue number by 0; for types with leads replace it by 1.

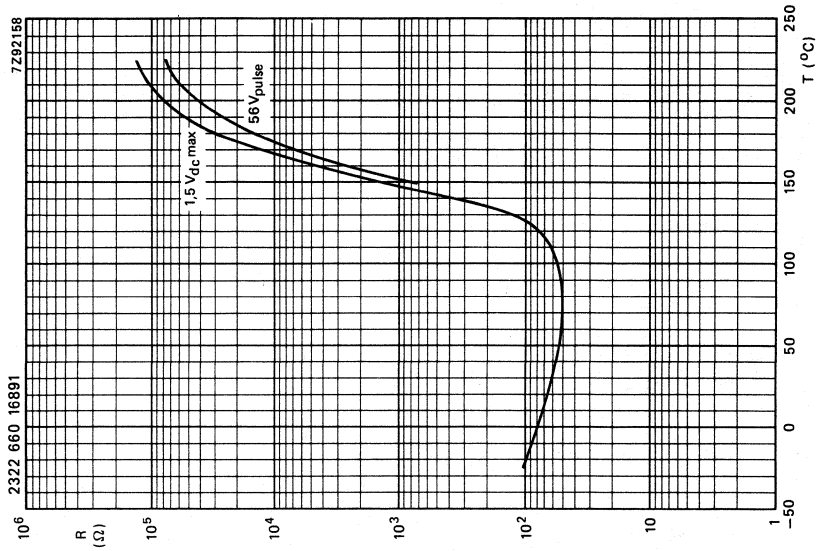

Fig. 3.

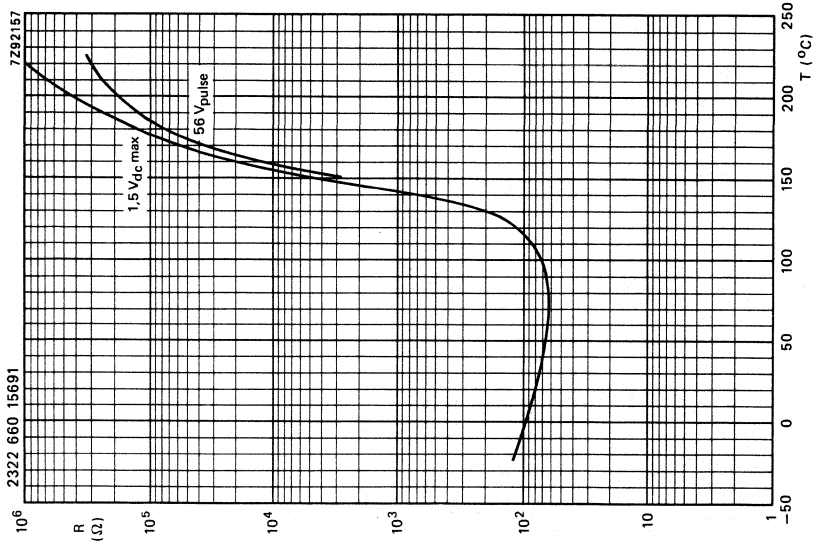

Fig. 2.

Typical resistance/temperature characteristics.

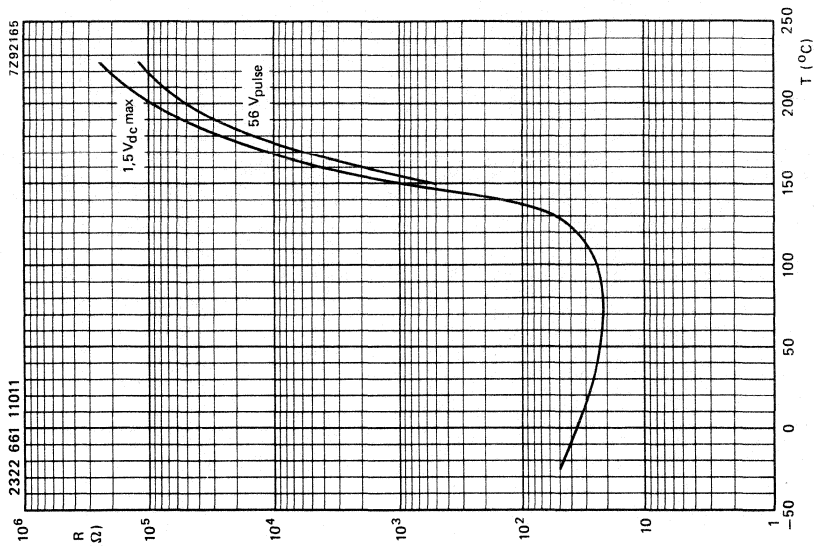

Fig. 5.

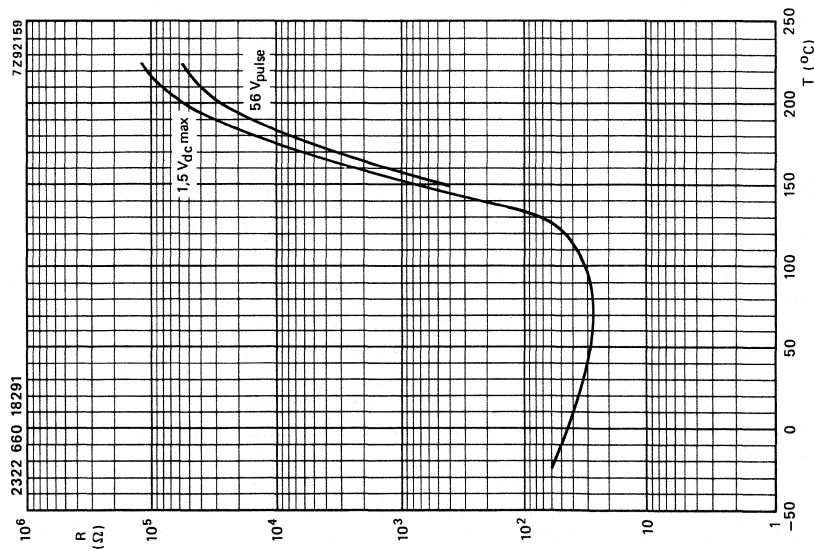

Fig. 4.

Typical resistance/temperature characteristics.

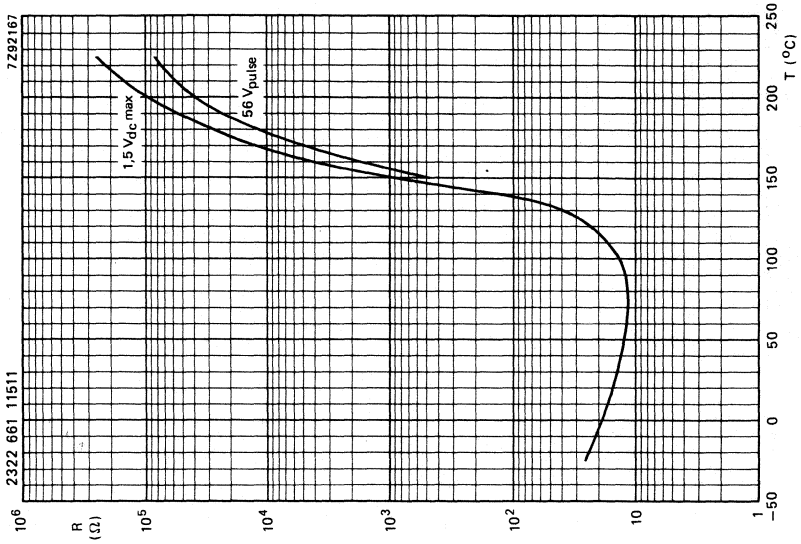

Fig. 7.

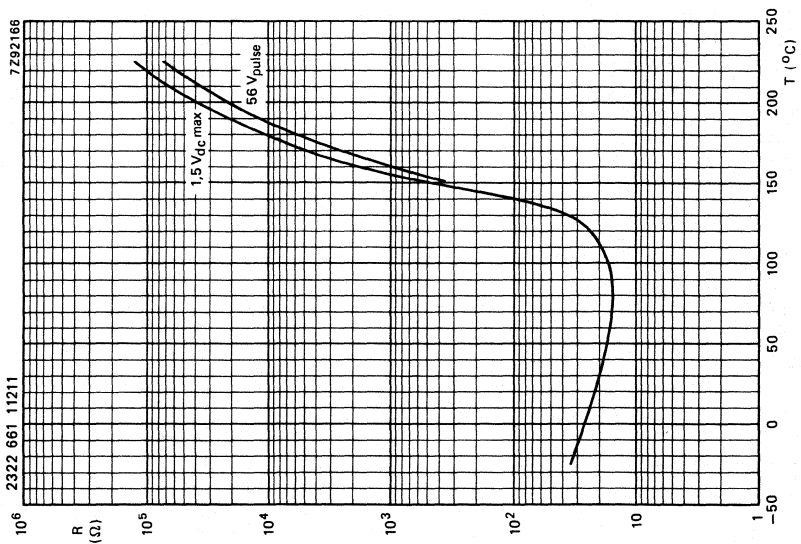

Fig. 6.

Typical resistance/temperature characteristics.

DEVELOPMENT DATA

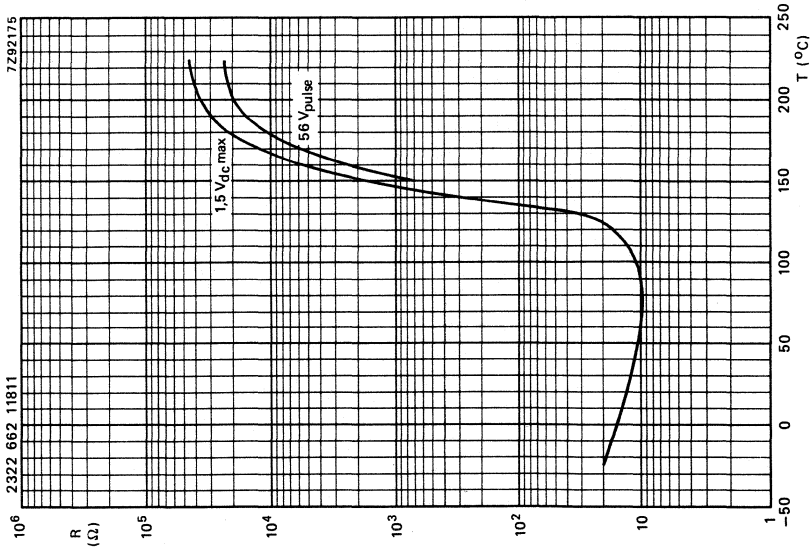

Fig. 8.

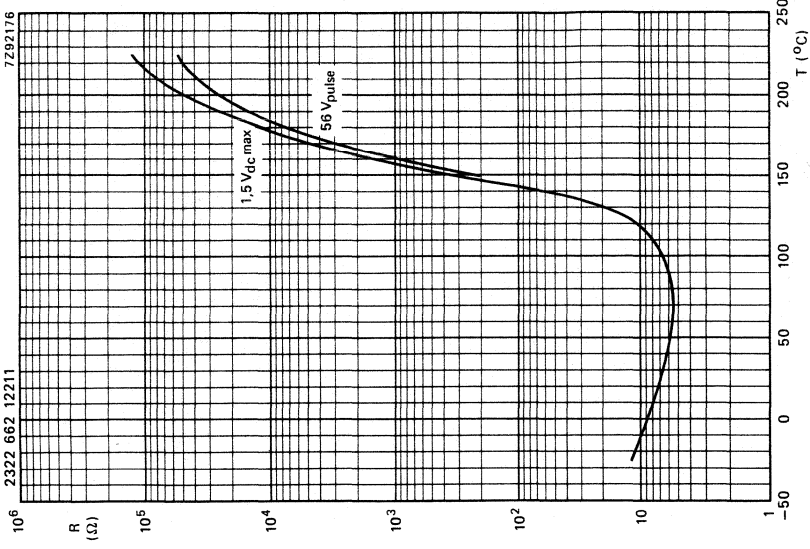

Fig. 9.

Typical resistance/temperature characteristics.

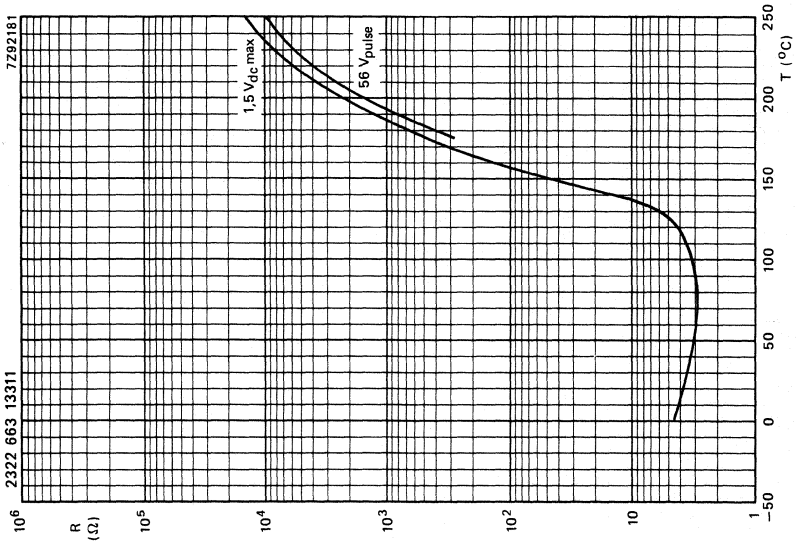

Fig. 11.

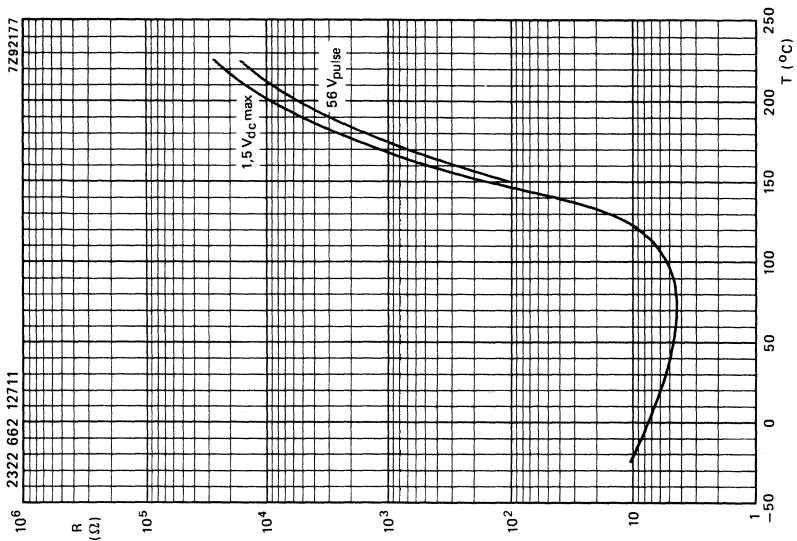

Fig. 10.

Typical resistance/temperature characteristics.

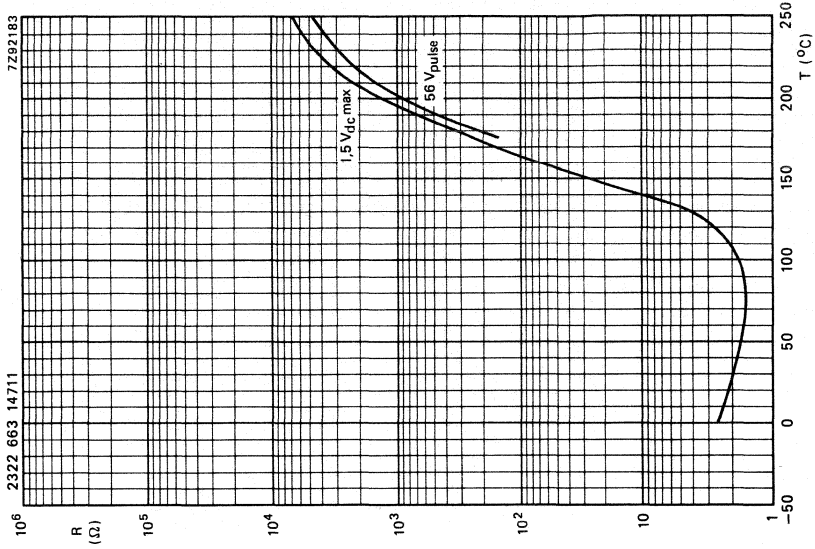

Fig. 13.

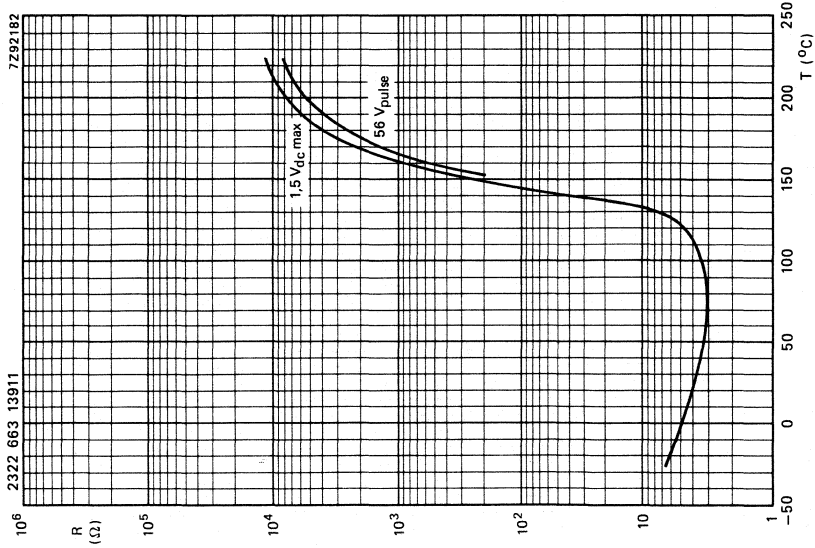

Fig. 12.

Typical resistance/temperature characteristics.

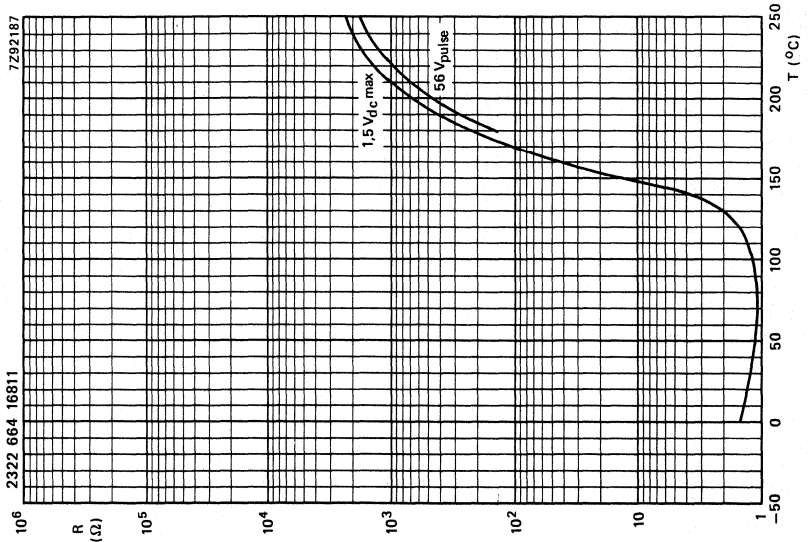

Fig. 15.

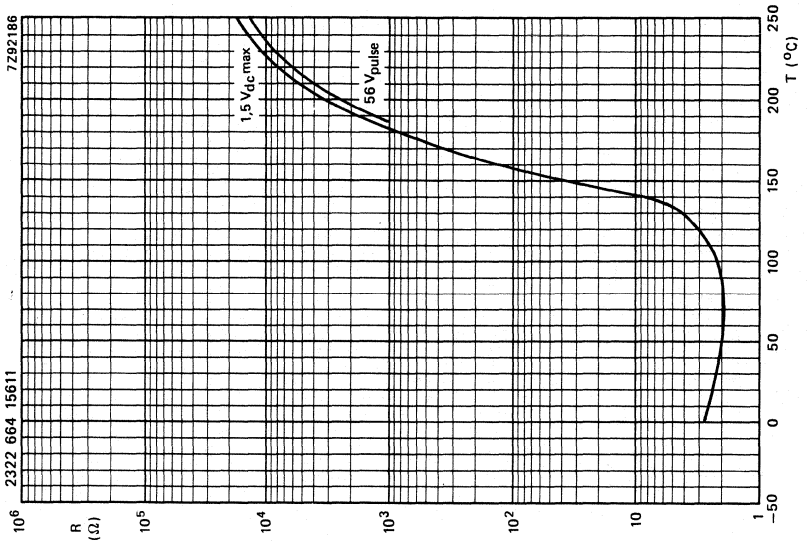

Fig. 14.

Typical resistance/temperature characteristics.

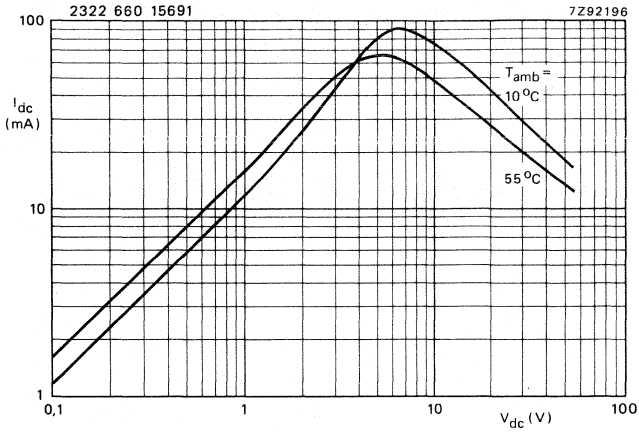

Fig. 16.

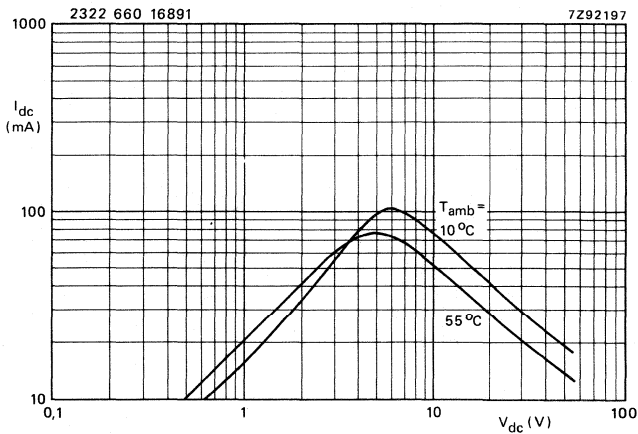

Fig. 17.

Typical voltage/current characteristics.

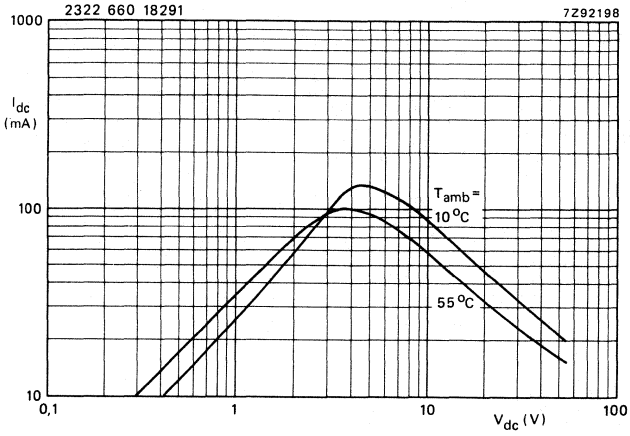

Fig. 18.

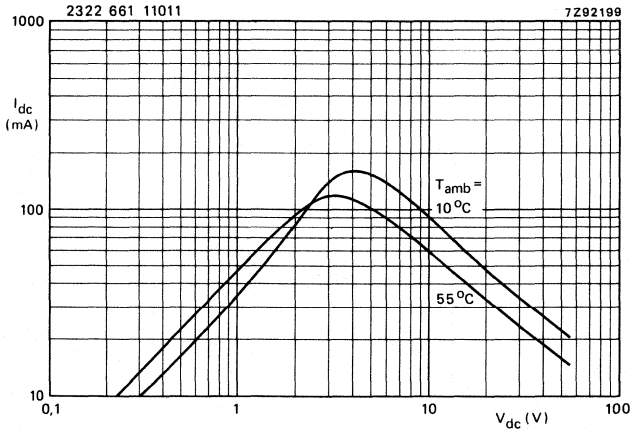

Fig. 19.

Typical voltage/current characteristics.

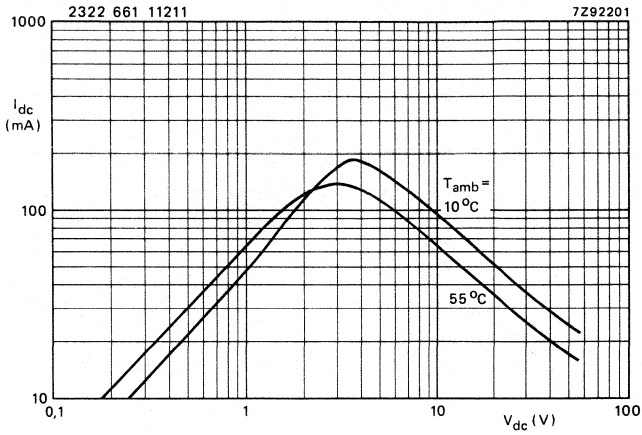

Fig. 20.

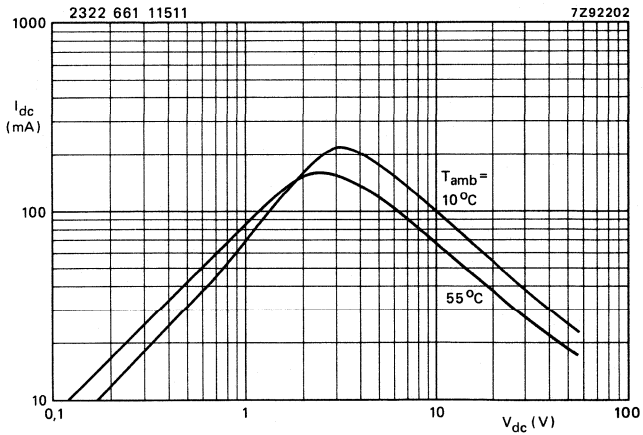

Fig. 21.

Typical voltage/current characteristics.

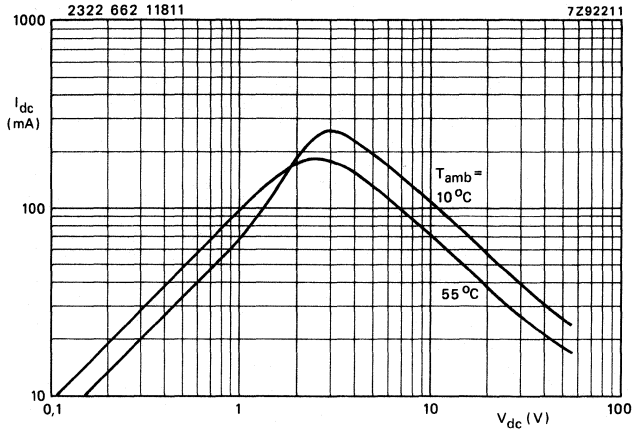

Fig. 22.

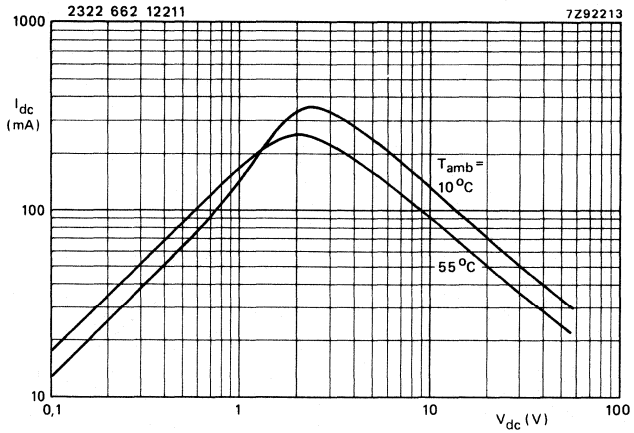

Fig. 23.

Typical voltage/current characteristics.

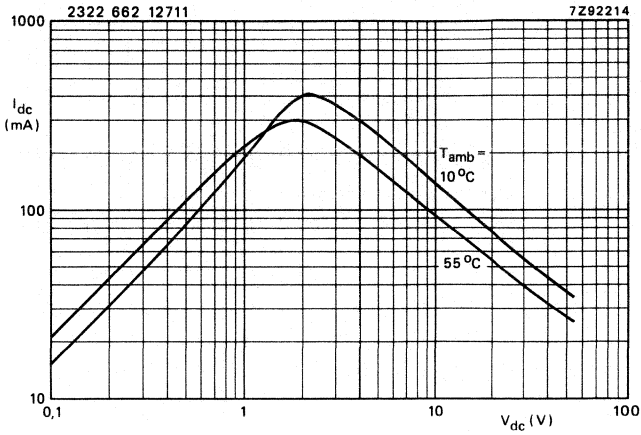

Fig. 24.

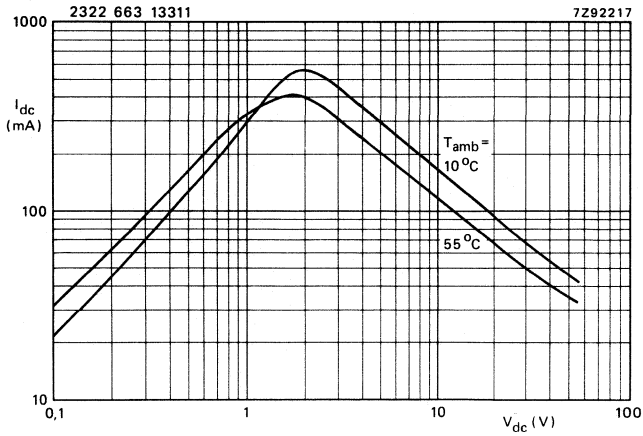

Fig. 25.

Typical voltage/current characteristics.

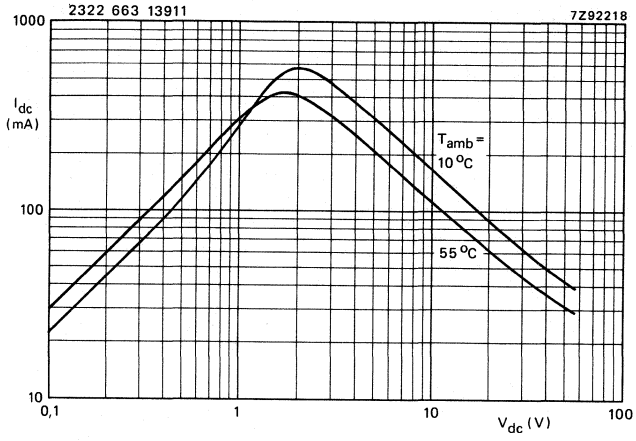

Fig. 26.

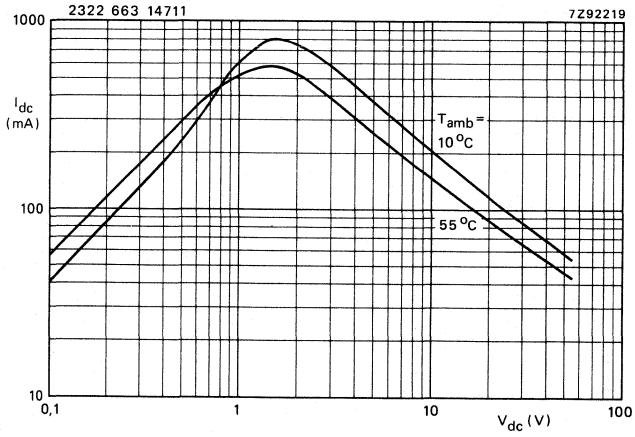

Fig. 27.

Typical voltage/current characteristics.

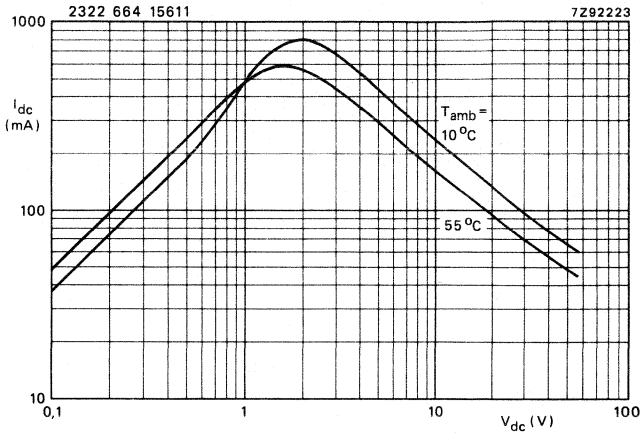

Fig. 28.

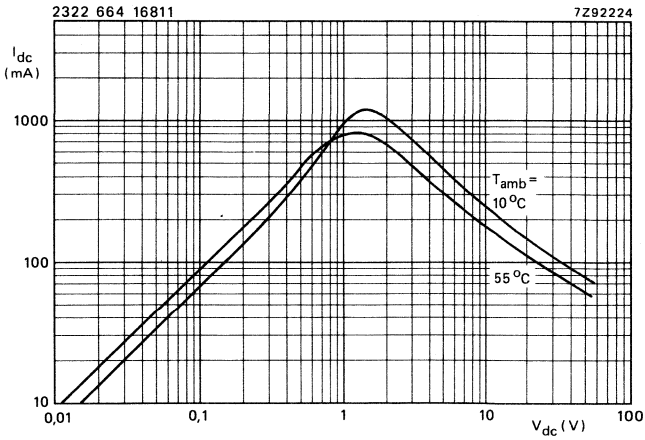

Fig. 29.

Typical voltage/current characteristics.

DEVELOPMENT DATA

This data sheet contains advance information and specifications are subject to change without notice.

2322 66. 0...3
2322 66. 1...3

PTC THERMISTORS

for overload protection

QUICK REFERENCE DATA

Resistance at 25 °C	3,5 to 1900 Ω
Switch temperature	approx. 120 °C
Maximum r.m.s. voltage	265 V
Trip current at 10 °C	24 to 940 mA
Operating temperature range at V_{max}	0 to +55 °C

APPLICATION

Overload protection; for use in electrical and electronic equipment such as electric motors, transformers and semiconductor circuits.

DESCRIPTION

These thermistors have a positive temperature coefficient. They consist of a disc with two tinned brass wires, see Fig. 1a. Leadless types having metallized sides for soldering by the user are also available, see Fig. 1b. ←

MECHANICAL DATA

Outlines

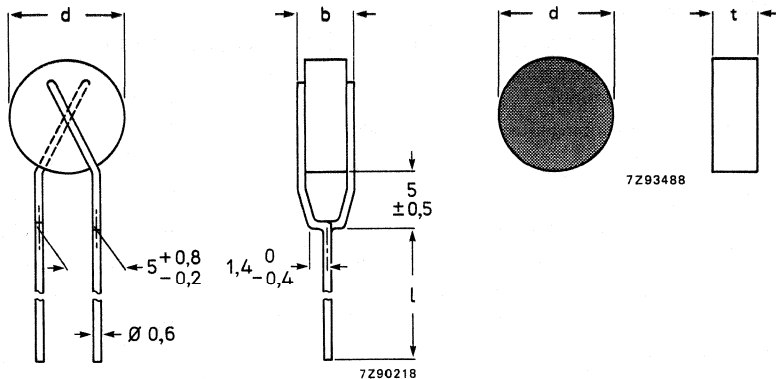

Fig. 1a.

Fig. 1b.

For dimensions b, d, l and t see Table 1.

Marking	None
Mass	See Table 1
Mounting	in any position by soldering
Robustness of terminations	
Tensile strength	10 N
Bending	5 N

Soldering

Solderability	max. 240 °C, max. 4 s
Resistance to heat	max. 265 °C, max. 11 s

→ When soldering leadless types it is recommended to use a flux containing colofonium and aethyl alcohol only and to pre-heat the discs to approx. 100 °C in order to avoid thermal shocks which might damage the thermistors.

Impact	200 mm free fall
---------------	------------------

Inflammability	Uninflammable
-----------------------	---------------

Packaging

Cardboard boxes containing following items for:

2322 660 3:	500	2322 662 3:	100
2322 661 3:	250	2322 663 3:	100
2322 662 . 1213:	200	2322 664 3:	100

ELECTRICAL DATA

Unless otherwise specified measured according to IEC publication 738-1 (1982)

Maximum current for not tripping at 55 °C (measuring time 5 minutes)	I_{nt}	See Table 1
Minimum current for tripping after 5 minutes at 10 °C	$I_t = 2 \times I_{nt}$	See Table 1
Resistance at + 25 °C	R ₂₅	See Table 1
Switch temperature	T _s	≈ 120 °C
Maximum admissible current at 0 °C	I _{max}	See Table 1
Maximum residual current at 265 V (r.m.s.) at 10 °C	I _{res max}	See Table 1
Maximum r.m.s. voltage with a series resistor		265 V
Series resistor	R _s	See Table 1
Dissipation factor at T _s	D	See Table 1
Heat capacity	H	See Table 1
Operating temperature range		
at zero power		-25 to + 125 °C
at minimum voltage		0 to + 55 °C

Table 1

catalogue number 2322 followed by	I_{nt} at 55 °C mA	I_t at 10 °C mA	R_{25} approx. Ω	I_{max} at 0 °C mA	$I_{res\ max}$ at 10 °C mA	R_s $\pm 5\%$ Ω	D approx. mW/K	H approx. J/K	d mm	b max. mm	l ± 3 mm	t max. mm	mass approx. g
2322 660 .1293	12	24	1900	110	5	1100	6	0,12	4,5	5	20	3,8	0,45
660 .1593	15	30	1200	135	5	1100	6	0,12	4,5	5	20	3,8	0,45
660 .1893	18	36	850	165	5	1000	6	0,12	4,5	5	20	3,8	0,45
660 .2293	22	44	560	200	6	910	6	0,12	4,5	5	20	3,8	0,45
660 .2793	27	54	380	250	6	820	6	0,12	4,5	5	20	3,8	0,45
661 .3393	33	66	280	290	7	750	7	0,22	6,5	5	20	3,8	0,70
661 .3993	39	78	200	350	7	620	7	0,22	6,5	5	20	3,8	0,70
661 .4793	47	94	140	420	7	560	7	0,22	6,5	5	20	3,8	0,70
661 .5693	56	112	100	500	8	470	7	0,22	6,5	5	20	3,8	0,70
661 .6893	68	136	72	600	8	390	8	0,33	8,0	5	20	3,8	0,90
661 .8293	82	164	50	730	9	330	8	0,33	8,0	5	20	3,8	0,90
661 .1013	100	200	33	900	9	270	8	0,33	8,0	5	20	3,8	0,90
662 .1213	120	240	26	1100	12	220	8,5	0,48	10,0	5	20	3,8	1,30
662 .1513	150	300	20	1300	12	200	9,5	0,68	12,0	5	20	3,8	1,80
662 .1813	180	360	14	1700	14	150	9,5	0,68	12,0	5	20	3,8	1,80
663 .2213	220	440	10	2100	16	120	10	0,85	13,0	5	20	3,8	2,15
663 .2713	270	540	8	2500	19	100	12	1,30	16,0	5	20	3,8	2,90
664 .3313	330	660	7	3000	25	82	16	2,40	20,0	6	16	4,8	5,30
664 .3913	390	780	5	3600	25	68	16	2,40	20,0	6	16	4,8	5,30
664 .4713	470	940	3,5	4300	25	56	16	2,40	20,0	6	16	4,8	5,30

For leadless types replace the dot in the catalogue number by 0; for types with leads replace it by 1.

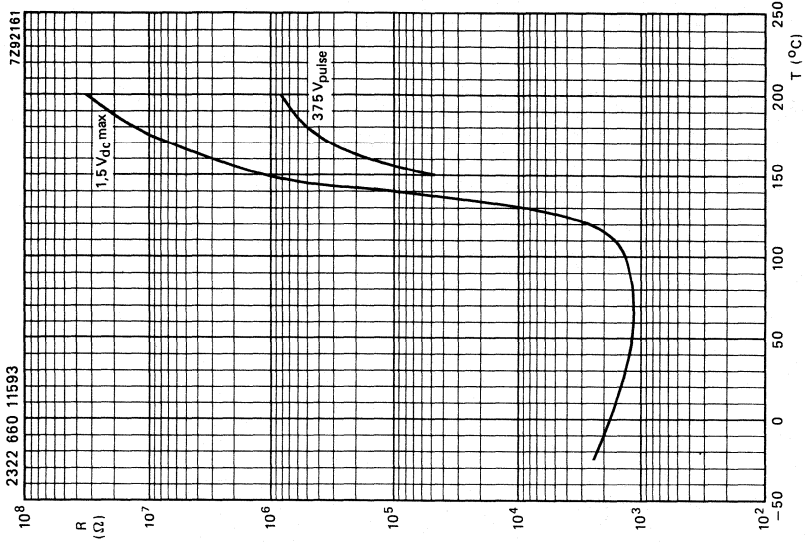

Fig. 3.

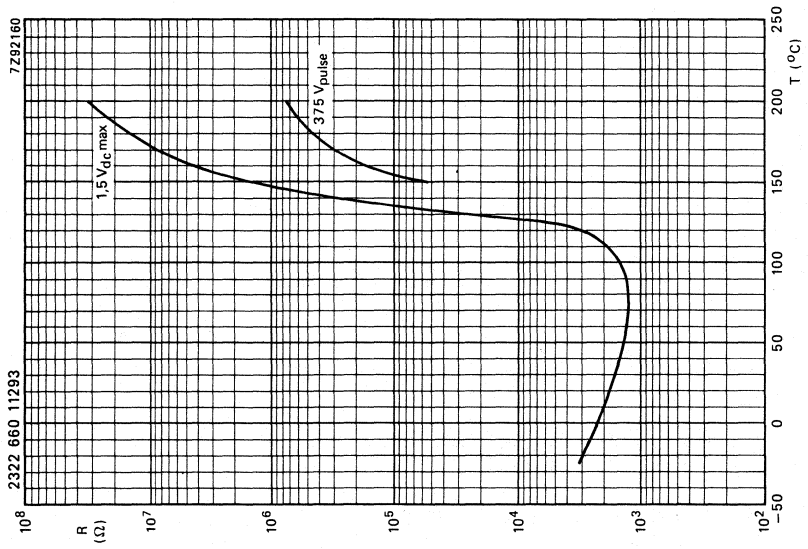

Fig. 2.

Typical resistance/temperature characteristics.

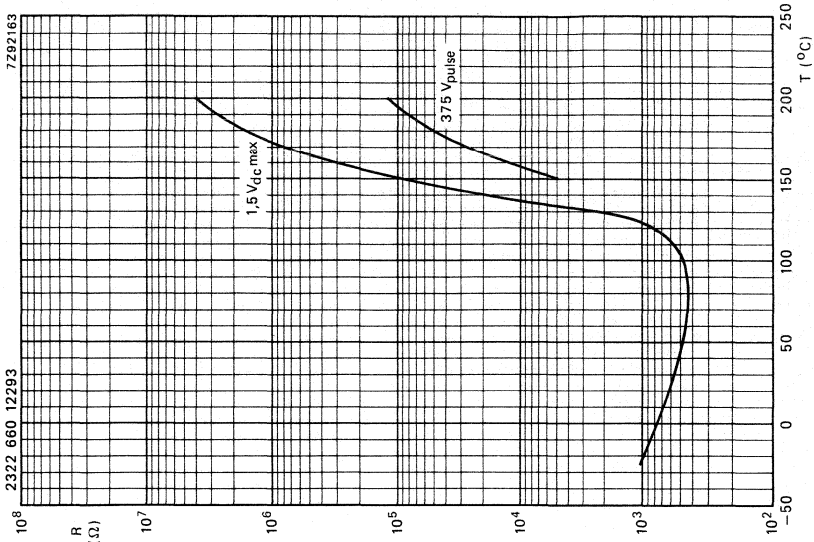

Fig. 5.

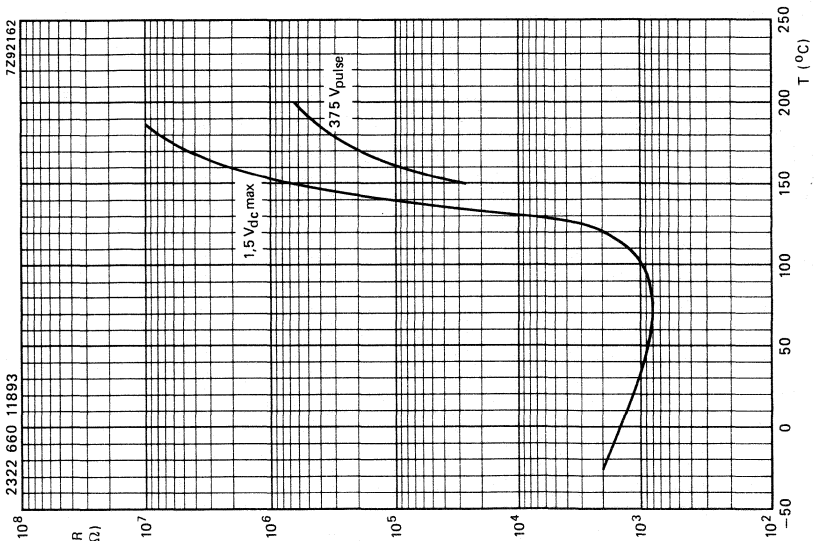

Fig. 4.

Typical resistance/temperature characteristics.

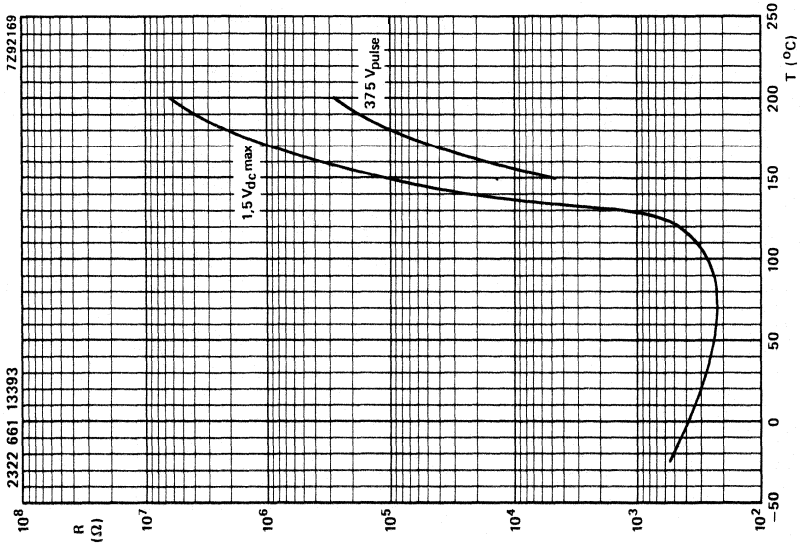

Fig. 7.

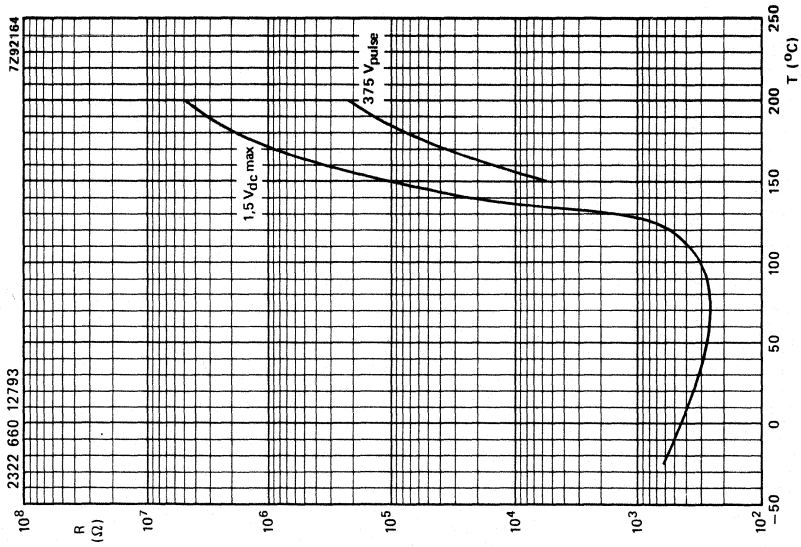

Fig. 6.

Typical resistance/temperature characteristics.

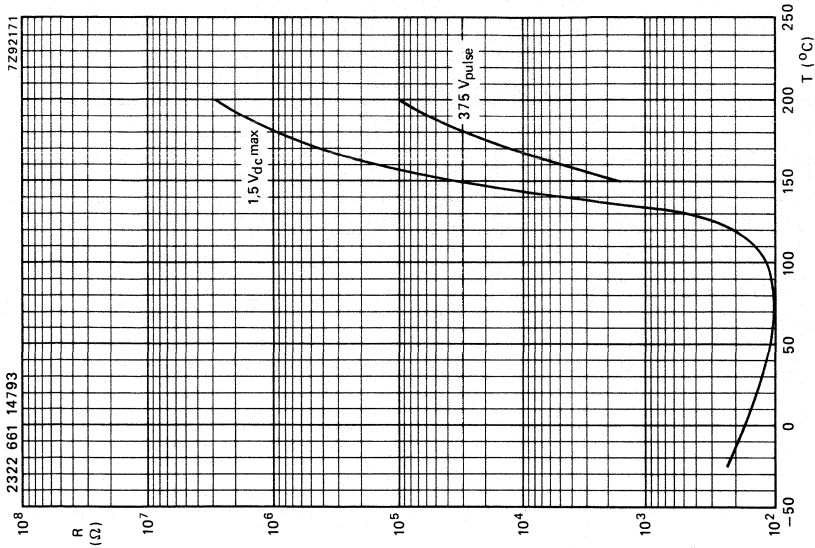

Fig. 9.

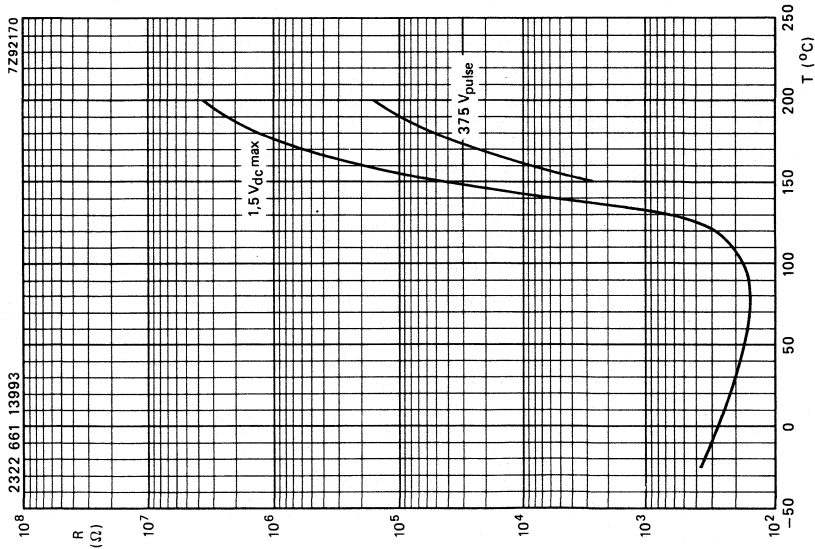

Fig. 8.

Typical resistance/temperature characteristics.

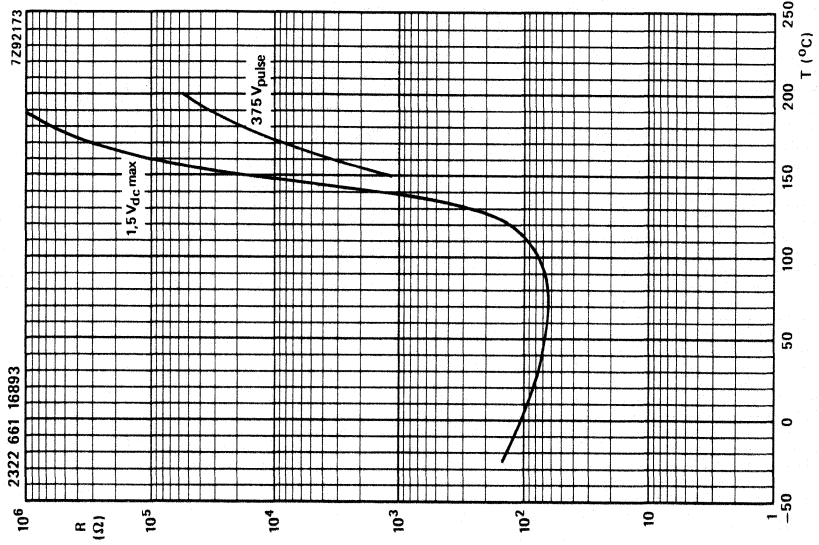

Fig. 11.

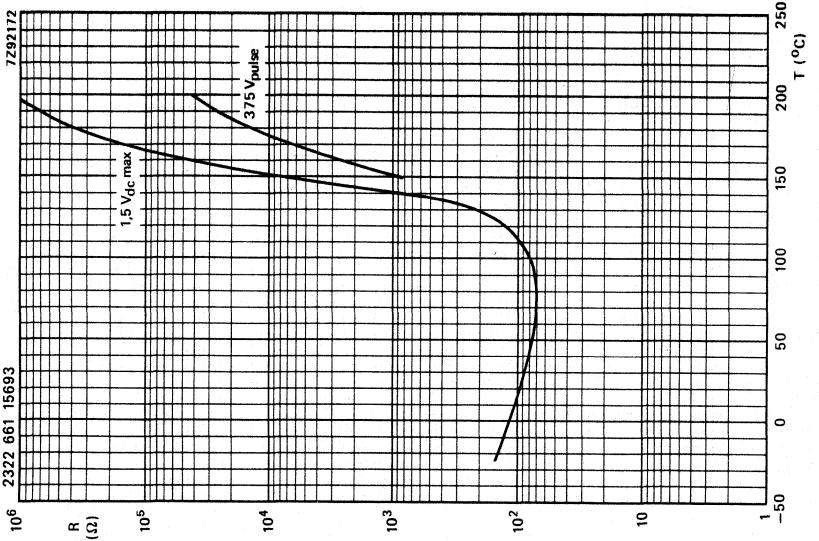

Fig. 10.

Typical resistance/temperature characteristics.

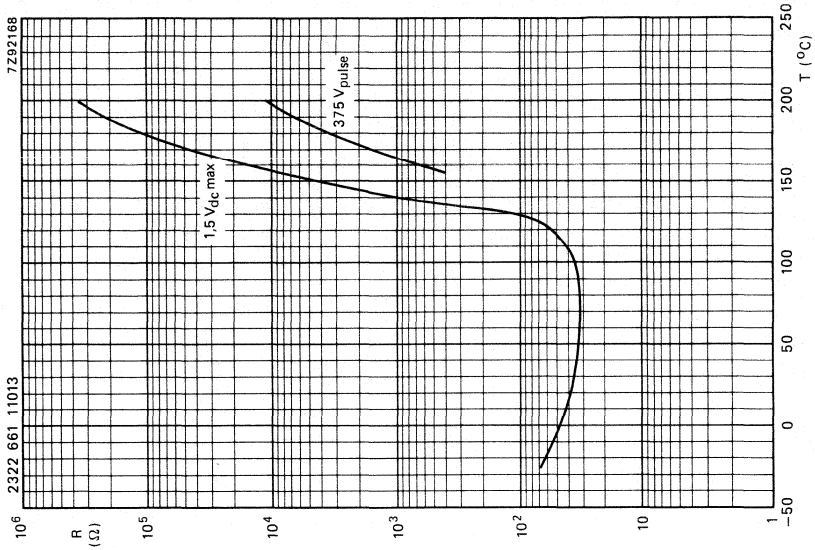

Fig. 13.

Typical resistance/temperature characteristics.

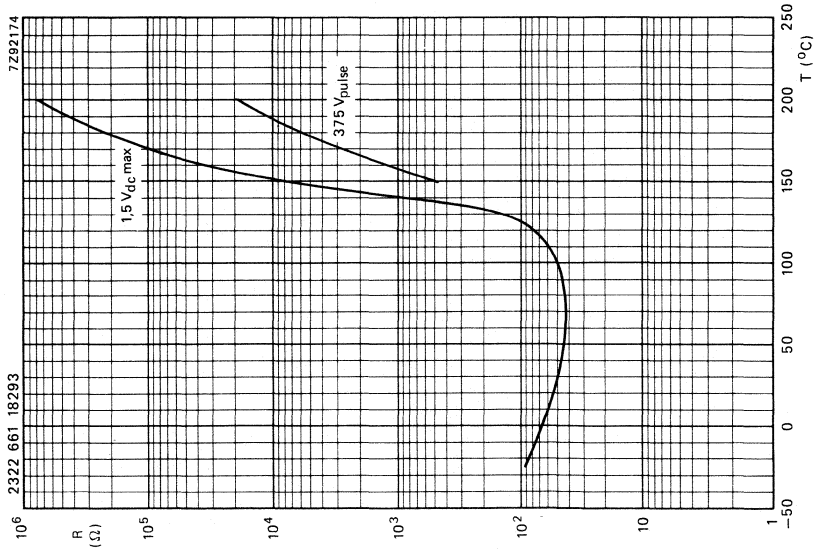

Fig. 12.

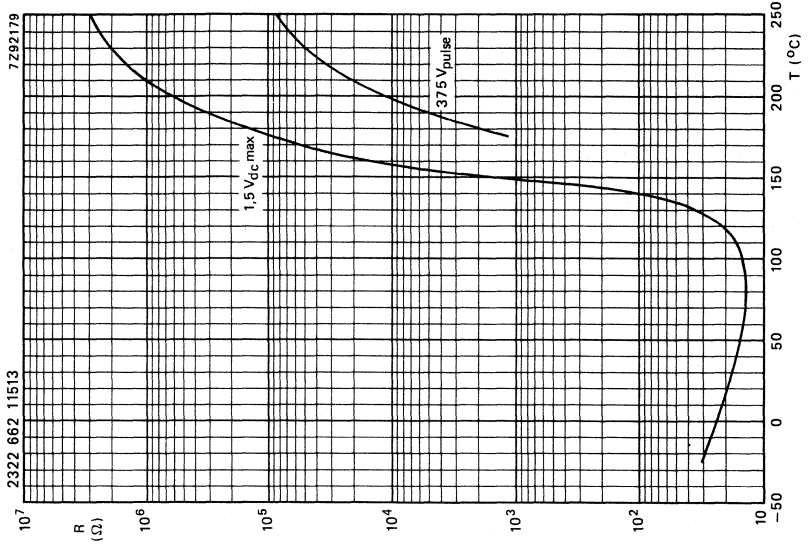

Fig. 15.

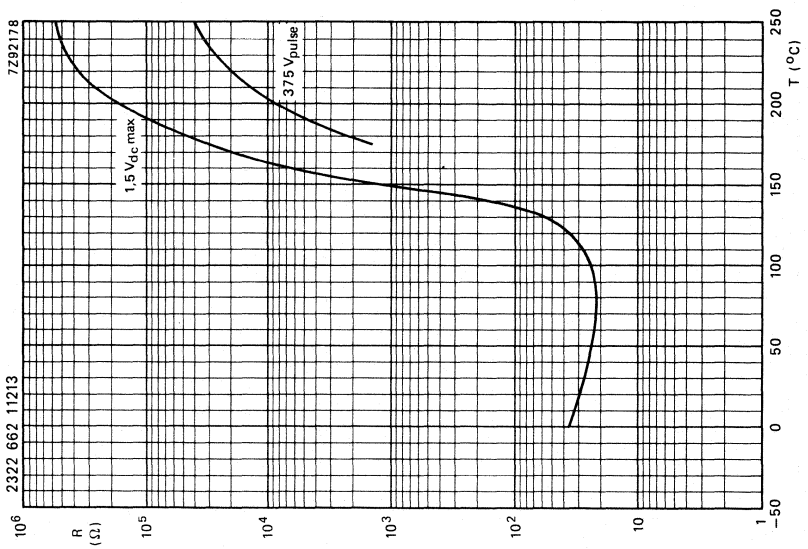

Fig. 14.

Typical resistance/temperature characteristics.

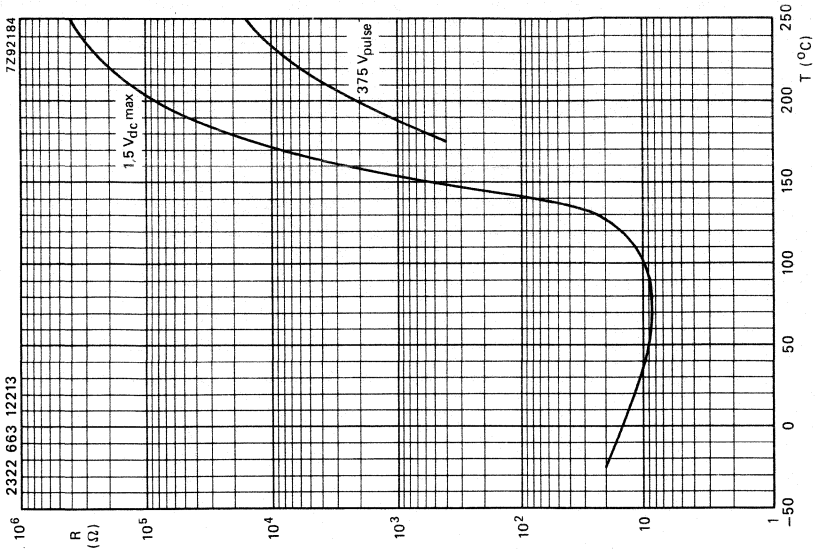

Fig. 17.

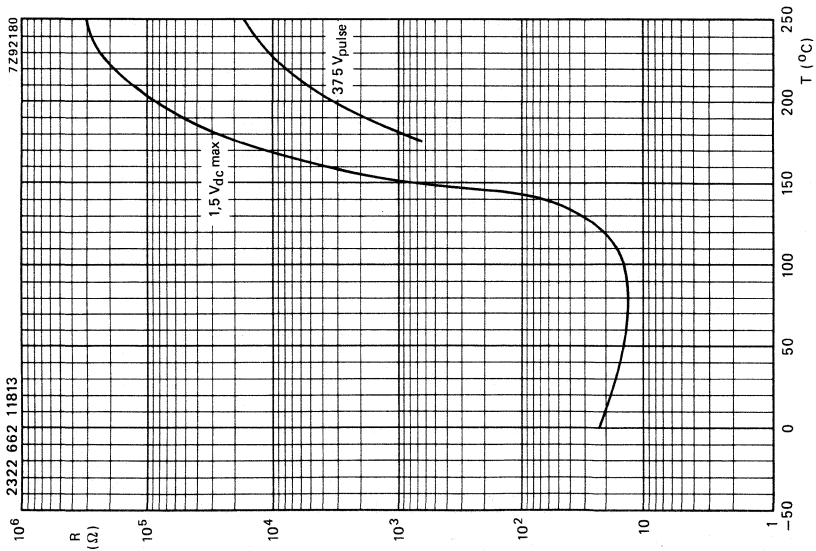

Fig. 16.

Typical resistance/temperature characteristics.

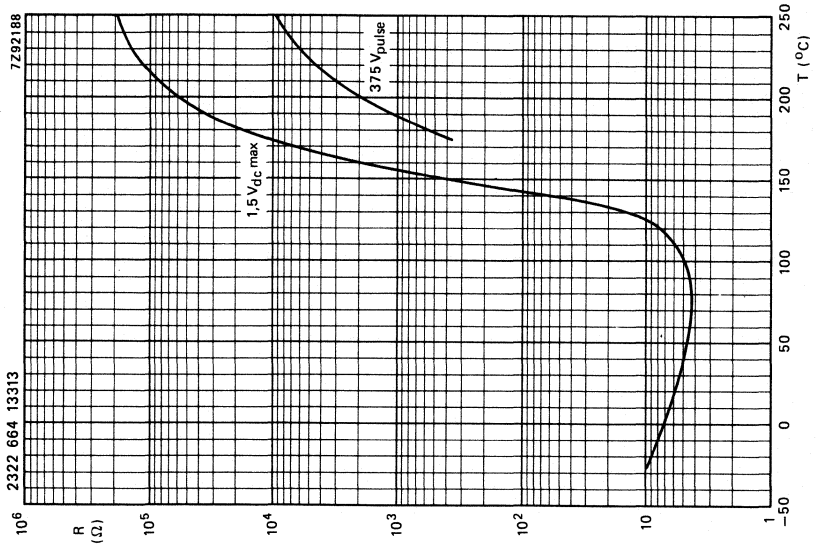

Fig. 19.

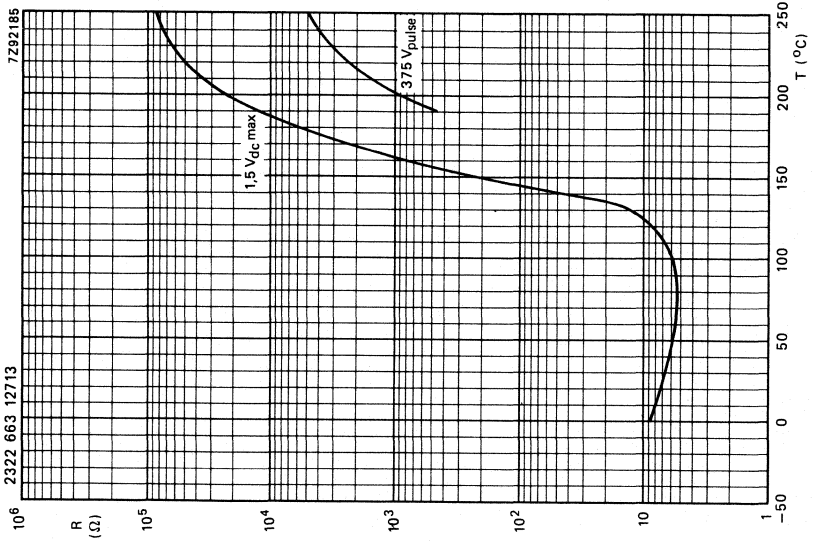

Fig. 18.

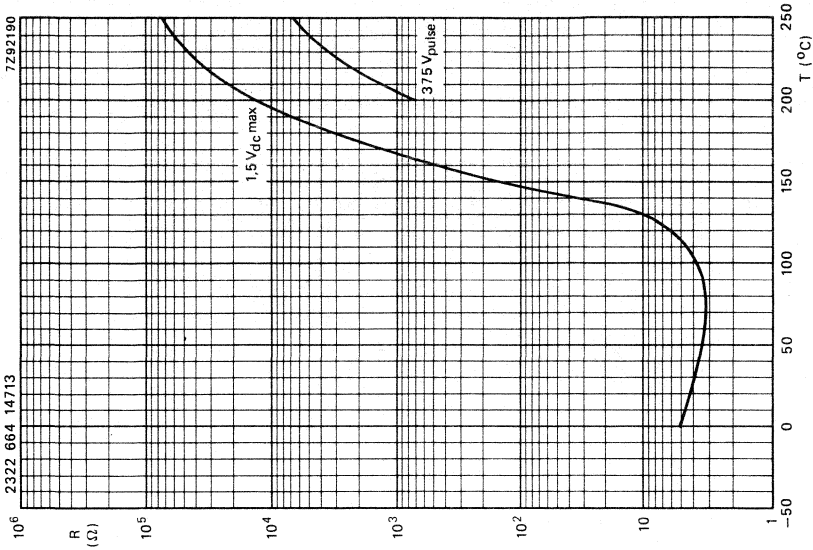

Fig. 21.

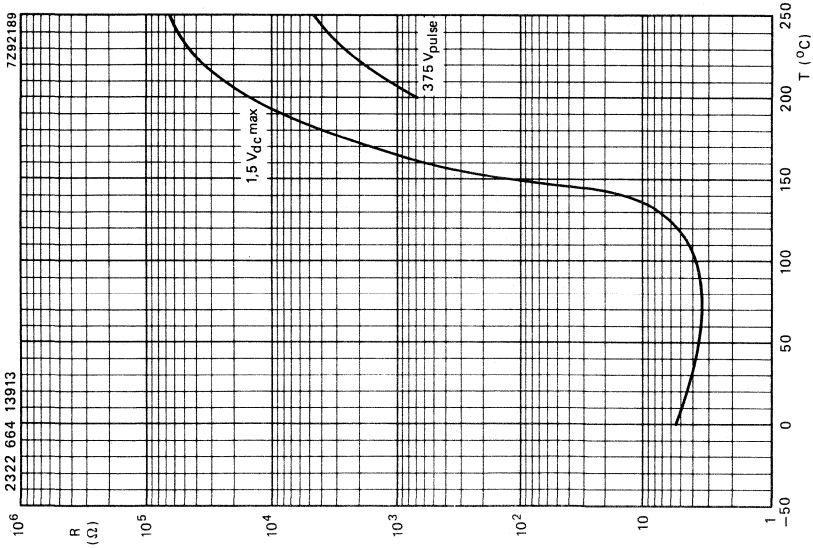

Fig. 20.

Typical resistance/temperature characteristics.

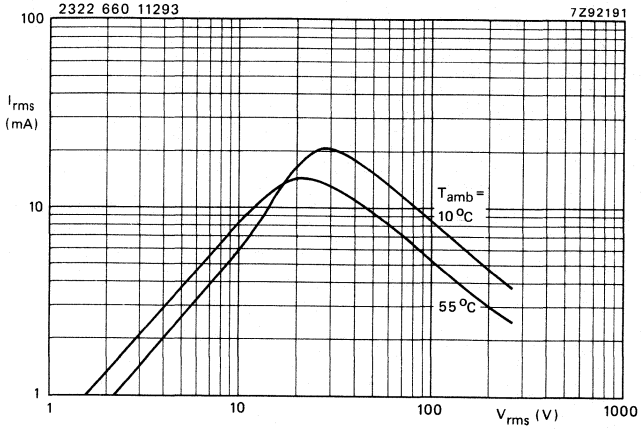

Fig. 22.

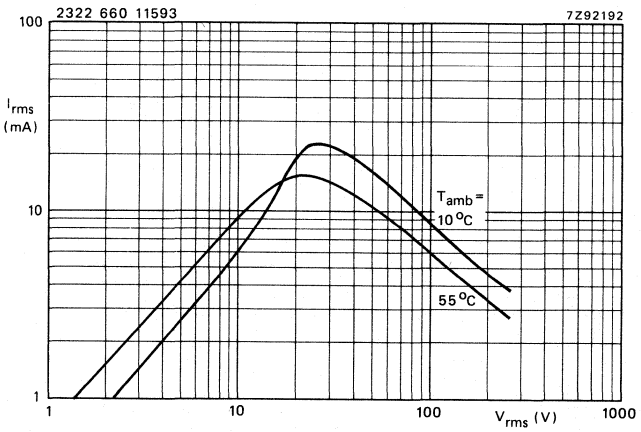

Fig. 23.

Typical voltage/current characteristics.

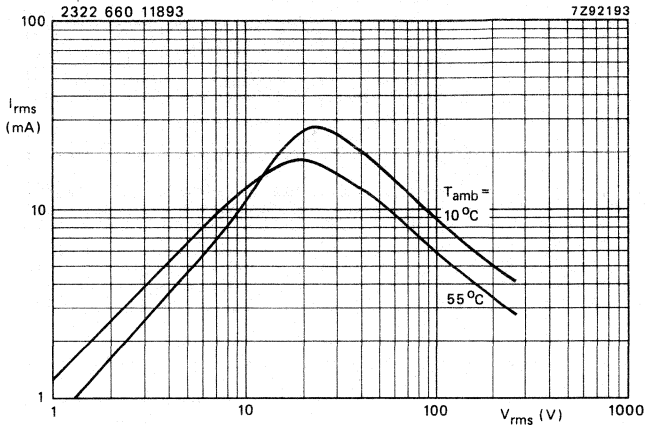

Fig. 24.

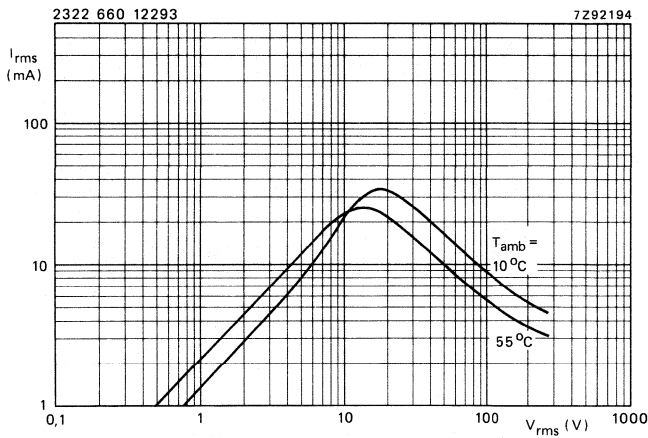

Fig. 25.

Typical voltage/current characteristics.

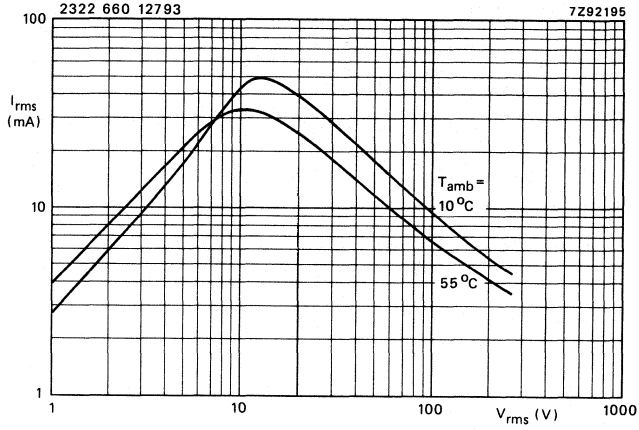

Fig. 26.

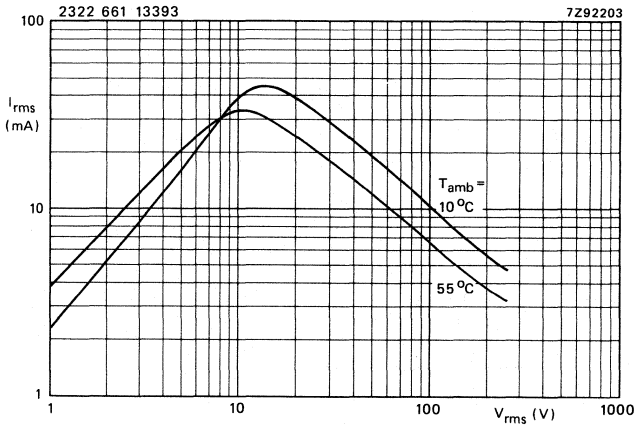

Fig. 27.

Typical voltage/current characteristics.

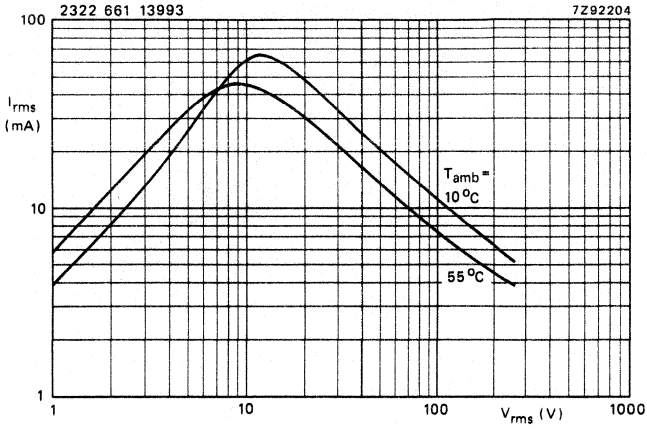

Fig. 28.

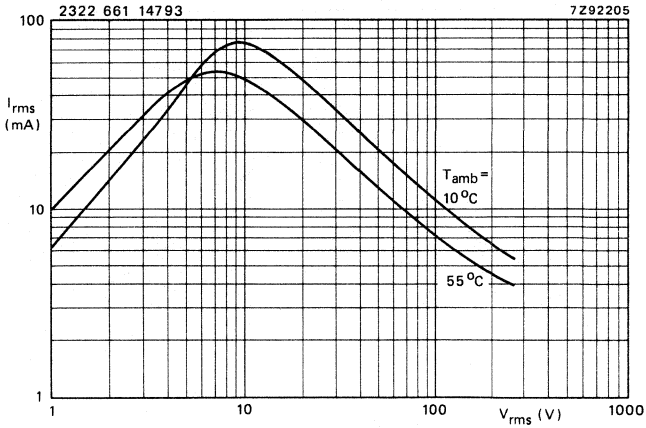

Fig. 29.

Typical voltage/current characteristics.

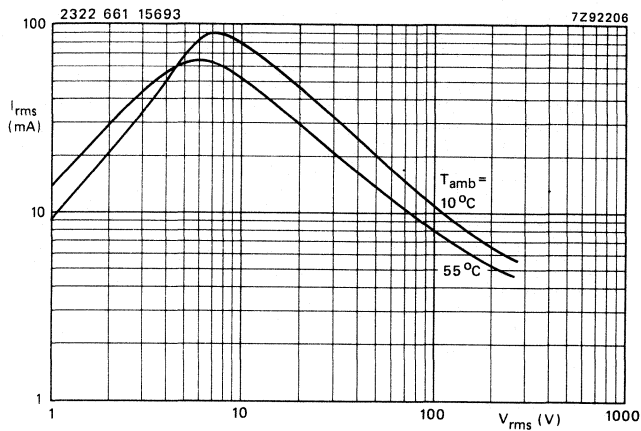

Fig. 30.

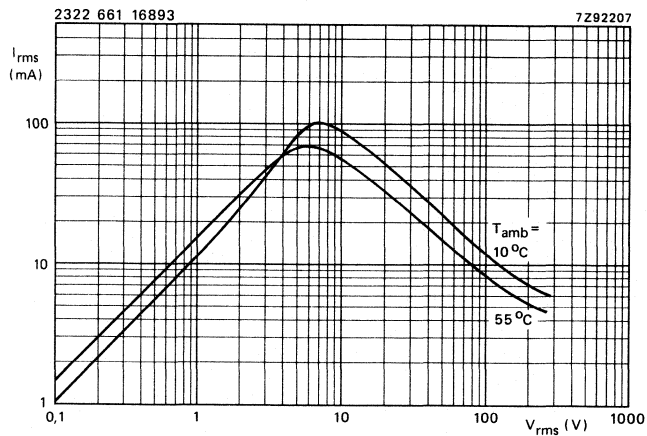

Fig. 31.

Typical voltage/current characteristics.

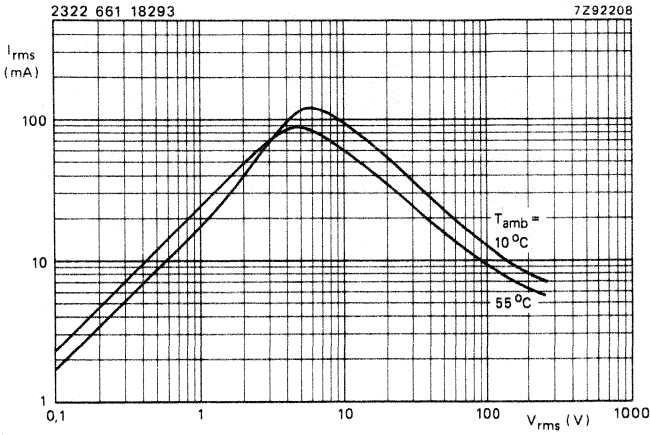

Fig. 32.

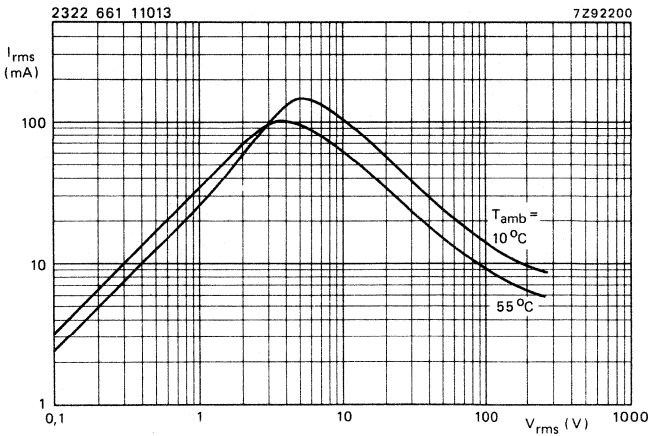

Fig. 33.

Typical voltage/current characteristics.

DEVELOPMENT DATA

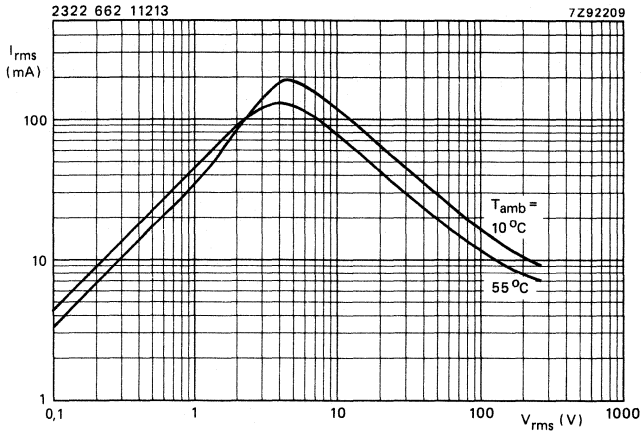

Fig. 34.

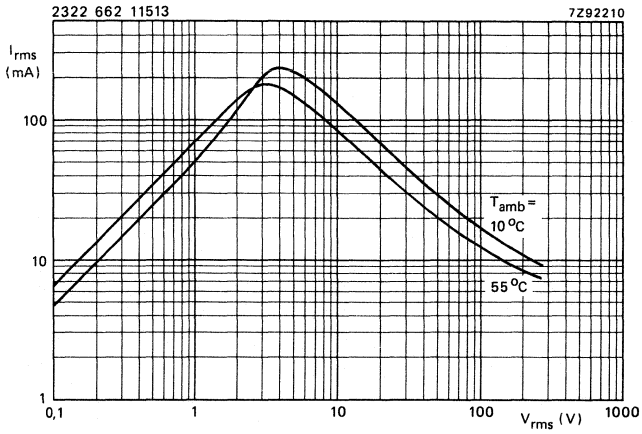

Fig. 35.

Typical voltage/current characteristics.

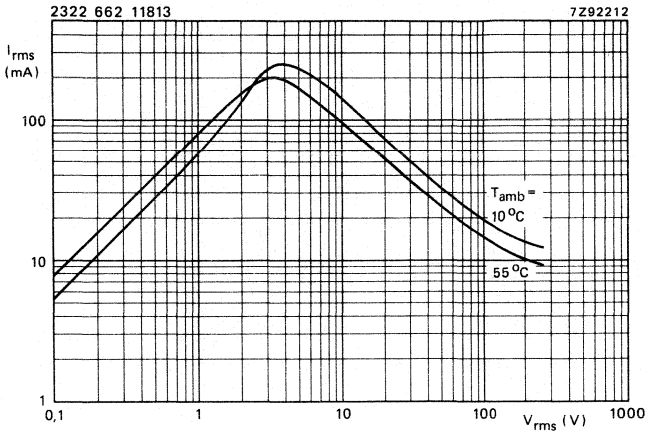

Fig. 36.

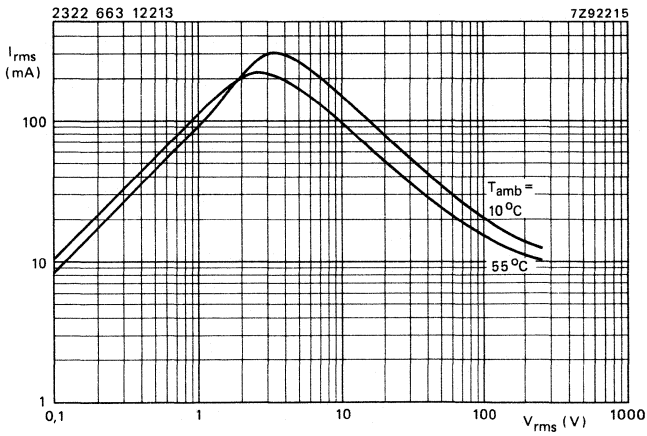

Fig. 37.

Typical voltage/current characteristics.

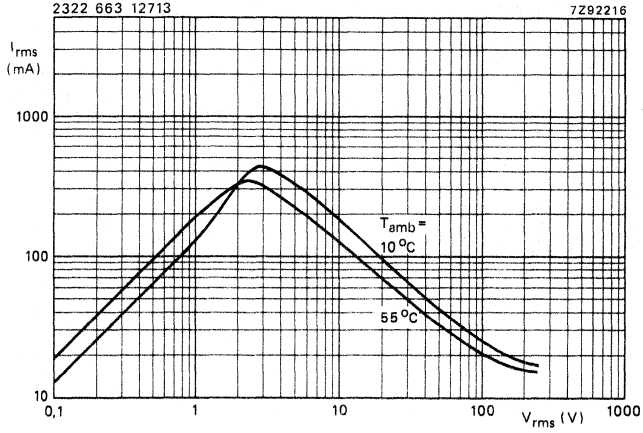

Fig. 38.

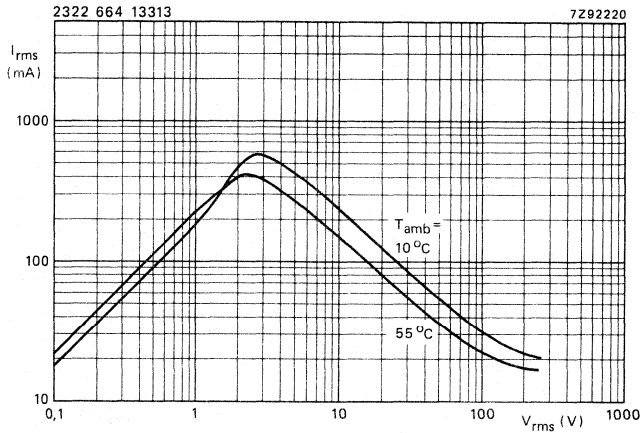

Fig. 39.

Typical voltage/current characteristics.

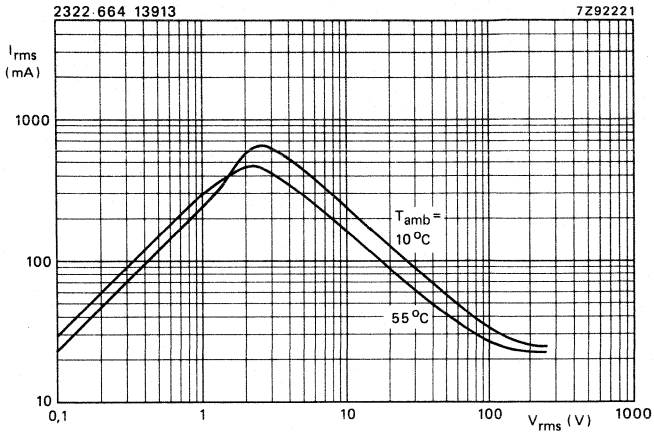

Fig. 40.

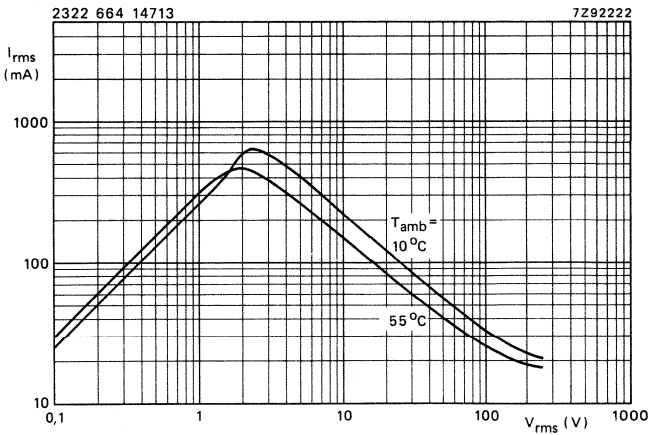

Fig. 41.

Typical voltage/current characteristics.

PTC THERMISTORS

for overload protection

QUICK REFERENCE DATA

Resistance at $T_{amb} = +25\text{ }^{\circ}\text{C}$	see Tables 2 and 3
Maximum resistance at $T_{amb} = +115\text{ }^{\circ}\text{C}$	see Tables 2 and 3
Switch temperature	+115 $^{\circ}\text{C}$
Maximum voltage (d.c. or r.m.s.)	60 V (Table 2) or 245 V (Table 3)
Dissipation factor	see Tables 2 and 3
Ambient temperature range at maximum voltage	0 to +55 $^{\circ}\text{C}$

APPLICATION

For protection of electric and electronic components against overload, e.g. motors, transformers, light dimmers, etc.

A selection from our range of PTC thermistors which are suitable for this purpose is given.

DESCRIPTION

These thermistors have a positive temperature coefficient. They consist of a disc with two tinned copper or brass wires. The thermistors are neither lacquered nor insulated.

MECHANICAL DATA

Outlines	see Figs 1 and 2
Marking	none
Mass	see Table 1
Mounting	in any position by soldering
Robustness of terminations	
Tensile strength	
Thermistors of Fig. 1	20 N
Thermistors of Fig. 2	10 N
Bending	
Thermistors of Fig. 1	10 N
Thermistors of Fig. 2	5 N
Soldering	
Solderability	max. 240 $^{\circ}\text{C}$, max. 4 s
Resistance to heat	max. 260 $^{\circ}\text{C}$, max. 11 s
Impact	
Free fall	1 m
Inflammability	uninflammable

Table 1 Outlines

Dimensions in mm

type	D ± 5%	L ± 5	C max.	d	mass approx. g
2322 661 91019	8	54	7	0,8	0,8
2322 661 93001	8	54	13	0,8	1,3
2322 662 91004	10	55	11	0,8	0,9
2322 662 91006	12	56	11	0,8	1,1
2322 662 93015	10	55	13	0,8	1,6
2322 662 93017	12	56	13	0,8	2,1
2322 663 91002	16	58	11	0,8	1,7
2322 663 93006	16	58	13	0,8	3,3
2322 664 91002	20	60	11	0,8	2,2
2322 664 93014	20	60	13	0,8	4,8

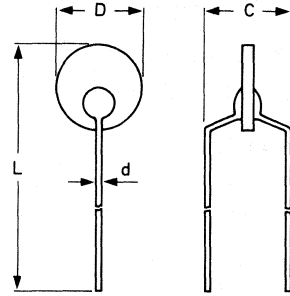
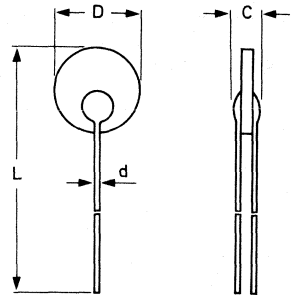

Fig. 1.

2322 660 91017	4,5	52,5	4	0,5	0,4
2322 660 93006	4,5	52,5	5,5	0,5	0,5
2322 660 93011	4,5	52,5	5,5	0,5	0,5
2322 660 93012	4,5	52,5	5,5	0,5	0,5
2322 660 93013	4,5	52,5	5,5	0,5	0,5
2322 660 93014	4,5	52,5	5,5	0,5	0,5
2322 661 91021	8	54	4	0,5	0,6
2322 661 93002	8	54	5,5	0,5	1,0
2322 662 91005	10	55	4	0,5	0,7
2322 662 91007	12	56	4	0,5	0,9
2322 662 93016	10	55	5,5	0,5	1,4
2322 662 93018	12	56	5,5	0,5	1,8
2322 663 91003	16	58	4	0,5	1,4
2322 663 93007	16	58	5,5	0,5	3,0
2322 664 91003	20	60	4	0,5	1,9
2322 664 93015	20	60	5,5	0,5	4,6
2322 672 91016	3	51,5	4	0,5	0,25
2322 672 93003	3	51,5	5,5	0,5	0,3



7271460.1

Fig. 2.

ELECTRICAL DATA

Table 2 Low-voltage PTC thermistors: V_{\max} at + 55 °C = 60 V; $T_s = + 115$ °C

R_{25} Ω ± 25%	R_{115} Ω max.	$I_{\text{stat peak}}$ A		I_{max} A	t_{resp} s	D mW/K	I_{res} mA	R_s Ω min.	catalogue number
		at 25 °C	at 55 °C	at 0 °C and 60 V	at 25 °C and I_{max}				
1,65	3,5	0,85	0,64	7,5	3	20	63	6,2	2322 664 91002
1,65	3,5	0,75	0,57	6,5	3	15	53	7,5	664 91003
2,3	5	0,63	0,47	5,25	3	15	51	9,1	663 91002
2,3	5	0,50	0,37	4,5	3	10	36	11	663 91003
3,7	7	0,44	0,33	3,5	3	12	39	13,5	662 91006
3,7	7	0,35	0,26	2,75	3	7,5	29	18	662 91007
5,6	12	0,34	0,25	2,7	3	11	31	16	662 91004
5,6	12	0,26	0,195	2	3	6,5	22	24	662 91005
9,4	20	0,25	0,19	1,9	3	10	28	22	661 91019
9,4	20	0,18	0,135	1,3	3	5	16	36	661 91021
25	55	0,09	0,068	0,65	3	4	12,5	68	660 91017
55	120	0,059	0,044	0,4	3	3,5	10,5	95	672 91016

Table 3 High-voltage PTC thermistors: V_{\max} at + 55 °C = 245 V; $T_s = + 115$ °C

R_{25} Ω ± 25%	R_{115} Ω max.	$I_{\text{stat peak}}$ A		I_{max} A	t_{resp} s	D mW/K	I_{res} mA	R_s Ω min.	catalogue number
		at 25 °C	at 55 °C	at 0 °C and 245 V	at 25 °C and I_{max}				
3,7	8	0,55	0,41	4,9	6	20	18	47	2322 664 93014
3,7	8	0,5	0,38	4,5	6	15,5	17	51	664 93015
6	15	0,4	0,3	3,0	6	16	16	75	663 93006
6	15	0,35	0,25	3,5	6	11	13	91	663 93007
10	25	0,27	0,2	1,8	7	12,5	14	120	662 93017
10	25	0,235	0,175	1,5	7	9	10	150	662 93018
15	40	0,215	0,162	1,3	7	11	14	180	662 93015
15	40	0,162	0,120	1	7	6,5	8,5	220	662 93016
25	60	0,150	0,115	0,9	7	10	11,5	240	661 93001
25	60	0,115	0,087	0,7	7	5,5	7	330	661 93002
70	160	0,059	0,045	0,25	8	4	5,5	910	660 93006
120	400	0,045	0,034	0,19	8	7	5	1100	660 93011
150	400	0,036	0,027	0,1	8	4	4,5	2200	672 93003
600	3000	0,020	0,015	0,085	8	7	4,5	2200	660 93012
1200	4000	0,014	0,011	0,060	8	7	4,5	2700	660 93013
1500	5000	0,013	0,010	0,055	8	7	4,5	3000	660 93014

Definitions of terms used in Tables 2 and 3.

V_{\max}	max. d.c. or a.c. voltage at + 55 °C.
$I_{\text{stat peak}}$	max. stationary operating current.
I_{max}	max. current at $T_{\text{amb}} = 0$ °C.
t_{resp}	time taken for the thermistor to reach the switching temperature.
D	dissipation factor measured in still air.
I_{res}	residual current at V_{\max} .

VARISTORS (VDR)

SELECTION GUIDE

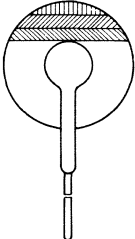
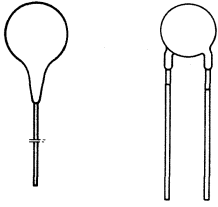
type	voltage V	current mA	dissipation W	β -value	catalogue number	page
DISC, silicon carbide		100 to 1	0,8	0,14 to 0,40	2322 552 0	323
ROD, silicon carbide	300 to 1300	1 to 10	0,8	0,16 to 0,25	2322 564 02 . . . 2322 564 90 . . .	327 327
SMALL DISC silicon carbide	9 and 18	1	0,1		2322 565 90003 2322 565 90006	330 330
zinc oxide		1	0,1	0,02 to 0,035	2322 592 2 2322 592 6 2322 593 2 2322 593 6 2322 594 2 2322 595 6	345 331 351 331 357 331
			0,1			
			0,25			
			0,25			
	100 to 750 47 to 750 100 to 750 47 to 750 100 to 750 47 to 750		0,4 0,6			

INTRODUCTION

Varistors, also called V(oltage) D(ependent) R(esistors), show a high degree of non-linearity between their resistance value and the applied voltage. They are made of non-homogeneous material giving a rectifying action at the contact of two particles.

Various materials are used to cause the voltage depending resistance. The principal ones are:

- silicon carbide;
- zinc oxide.

The electrical characteristic of the conglomeration is determined by a large number of crystal contacts which form a complicated network of series and parallel rectifying contacts.

These resistors have found a diversity of applications in the different sectors of electronics. They offer a cheap and reliable solution for protection of electronic circuits, semiconductor components, collectors of motors, relay contacts, etc. against over-voltages and their consequences.

MANUFACTURING PROCESS

Crystals of silicon carbide, or of metal oxides, with the right electrical and dimensional properties are pressed together with a ceramic binder to the shape of discs or rods. After a drying period the varistors are sintered at a high temperature. Firing time, temperature and gaseous atmosphere have an important influence on the electrical characteristics. The contacts are metallized with silver or copper enabling good electrical contact. After leads have been soldered to the contacts the varistors are lacquered and coded. Some types, made for clamp contacts or other mounting methods, are delivered unlacquered and without leads.

During and after the manufacturing process the electrical properties are controlled not only to ensure that the varistors are within the specification but also to control stability and reliability of the resistors.

ELECTRICAL PROPERTIES

DIRECT CURRENT

The relation between voltage and current of a varistor can be approximated by:

$$V = C.I^\beta \tag{1}$$

where V is the voltage in volts, I the current in amperes and C and β are constants. This equation is illustrated in Fig. 1. In principle the same characteristic is plotted for a specific type on a double logarithmic scale in Fig. 2. For not too small values of current this relation is a straight line which follows directly from the equation $\log V = \log C + \beta \log I$. In this case β is the directional coefficient of the straight line.

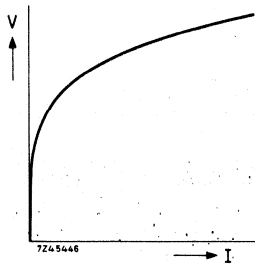

Fig. 1 Shape of the voltage/current characteristic of a varistor when plotted on a linear scale.

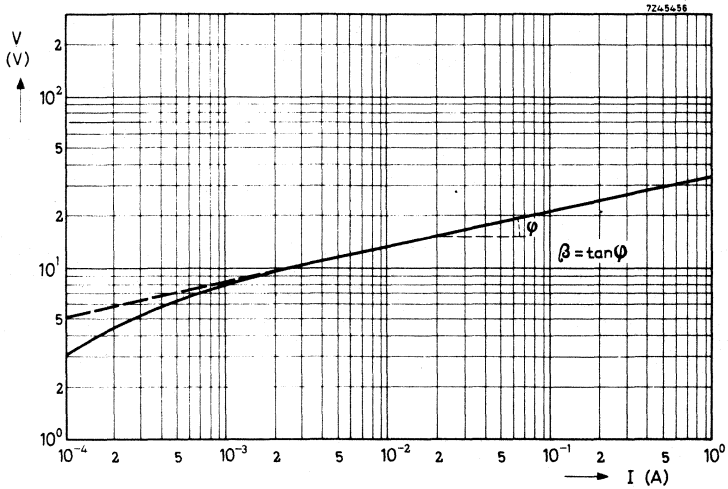

Fig. 2 Voltage/current characteristic of a varistor plotted on a logarithmic scale.

In order to determine the exact values of the constants C and β it is necessary to measure three points of the characteristic. Only when these are on a straight line when plotted on a double logarithmic scale, is extrapolation permitted (only to higher values). Equation (1) may also be written:

$$I = \left(\frac{V}{C}\right)^\alpha \tag{2}$$

in which:

$$\alpha = 1/\beta \tag{3a}$$

and

$$K = \frac{1}{C^{1/\beta}} = \frac{1}{C^\alpha} \tag{3b}$$

The varistors do not have a polar effect; this means that when the voltage is changed from positive to negative, the current changes its direction, but retains its value. Strictly speaking, Eqs (1) and (2) are valid only when the absolute values are taken for I and V. In a.c. calculations this may be very important. For practical design, reference is made to the voltage/current characteristics given in the data sheets of the relevant varistor types.

Practical values and specification

The C and β -values of varistors depend on the composition of the material and on the method used in the processing; furthermore, the C-value depends on the shape and the dimensions of the varistor. Practical β -values are for SiC: $\beta = 0,15$ to $0,40$, and for ZnO: $\beta = 0,02$ to $0,035$.

It is inherent to the material properties that the β -value of a varistor with a low C-value will always be higher than that of a varistor with a high C-value. Practical C-values range from 14 to a few thousand. As the method of fabrication compels a minimum thickness and, as will be seen further, enlarging of the surface area gives little change in the C-value, the latter has for practical reasons a limited lowest value.

According to Eq. (1) it is possible to specify the electrical characteristics of a varistor by giving its C and β -values. The advantage of this specification is that only two parameters are used. The disadvantage is, however, that due to the inevitable tolerances on the β -values, the spread in voltages at low currents (in the working area) becomes very large. It is for this reason that the method of specifying by the C -value defined at 1 A is abandoned and we now specify the voltage across the varistor at currents which lie in the working area (1, 10 or 100 mA instead of 1 A). In this way it is possible to supply varistors which have much closer tolerances in the area where they are used, see Fig. 10.

Varistors in series

For each varistor we can write the equation:

$$V = CI^\beta. \quad (1)$$

When n equal elements are connected in series and a voltage of n times the original voltage is applied, the current will be the same as for V volts over one varistor. Consequently we may write for a series circuit of n varistors:

$$nV = C'I^\beta. \quad (4)$$

From Eqs (1) and (4) it is evident that,

$$C' = nC, \quad (5)$$

which means that the C -value of a varistor can be increased ad libitum by series connection.

Varistors in parallel

For one varistor again we have:

$$V = CI^\beta. \quad (1)$$

Now when n of these varistors are connected in parallel and the same voltage V is applied, the current in each varistor will still be the same. The total current in the circuit will be nI . This gives the following equation:

$$V = C''(nI)^\beta. \quad (6)$$

From Eqs (1) and (6) it follows:

$$C'' = \frac{C}{n^\beta}. \quad (7)$$

As varistors have a β -value from 0,02 to 0,40, it is clear that the C-value will decrease very little by connecting two or more elements in parallel. When, e.g. $\beta = 0,20$, 32 varistors are needed for a 50% reduction of the C-value. It is important that in parallel circuits all varistors have about the same β and C-values, otherwise the current division will very much depend on the voltage across the circuit.

Note: On no occasion may a varistor be connected in parallel with the aim of obtaining higher power dissipation.

Resistance value

When defining R as usual as the quotient of voltage and current, we find:

$$R = \frac{V}{I} = \frac{CI^\beta}{I} = \frac{C}{I^{1-\beta}} \tag{8}$$

or when starting from the form $I = (\frac{V}{C})^\alpha$:

$$R = \frac{V}{I} = \frac{V}{\frac{V^\alpha}{C^\alpha}} = \frac{C^\alpha}{V^{\alpha-1}} \tag{9}$$

From these equations it is once more evident that the resistance value is not a constant one, but is very much dependent on the values of voltage and current.

Dissipated power

The power dissipated in a varistor is equal to the product of voltage and current, so it may be written:

$$W = I \cdot V = (\frac{V}{C})^\alpha \cdot V = \frac{V^{\alpha+1}}{C^\alpha} \tag{10}$$

When the coefficient $\alpha = 5$, the power dissipated by the varistor is proportional to the 6th power of the voltage. A voltage increase of only 12% will, in this case, double the dissipated power. Consequently it is very important that the applied voltage does not rise above a certain maximum value, as otherwise the permissible rating will be exceeded.

This is even more cogent, as the varistors have a negative temperature coefficient, which means that at higher dissipation (and accordingly higher temperature) the resistance value will decrease and the dissipated power will increase still more.

Temperature coefficient

In the foregoing formulae no temperature effects have been taken into account. These, however, may not always be neglected, as the C-value has an appreciable negative temperature coefficient. The β -value is practically independent of the temperature. With good approximation it may be written:

$$C_t = C_0 (1 + at), \tag{11}$$

in which:

C_t = C-value of the varistor at t °C;

C_0 = C-value of the varistor at 0 °C;

a = temperature coefficient.

For different materials the value of a lies between $-0,0010$ and $-0,0018$. Thus, for circuits where the current is constant, the temperature coefficient on voltage lies between $-0,10$ and $-0,18\%$ per degree K.

For circuits where the voltage is constant the temperature coefficient on current lies between $+0,4$ and $+0,8\%$ per degree K, depending on the β -value.

High frequency alternating current

For low frequencies the small capacitance of the varistor does not affect the voltage dependency of the resistance. For high frequencies, however, this parallel capacitance may not be neglected. For low voltages and currents they may even determine the impedance of the varistor. At high voltages, the influence of the capacitance is less serious; because in that case the resistance over which this capacitance is shunted has decreased. In general the effect of the capacitance in h.f. circuits will be an apparent increase of β . Furthermore the voltage/current graph on a logarithmic scale will no longer be a straight line.

A number of curves demonstrating this effect are given in Fig. 8.

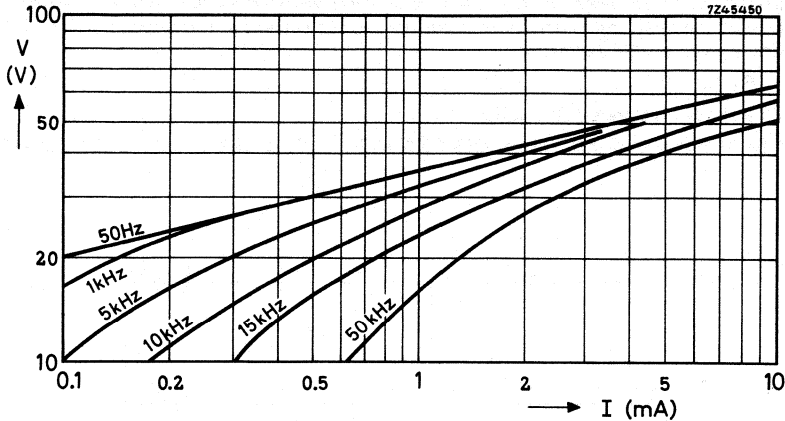

Fig. 8 Voltage/current relation for different frequencies.

PERMISSIBLE DISSIPATION

The temperature which a varistor will reach is determined by the dissipated power, the heat conductivity of the material, the contact with, and the nature of, the surrounding medium and by the ambient temperature. As already explained the dissipated power will increase rapidly with increasing voltage.

The cooling per degree Celsius, though increasing slightly with temperature, depends mainly on the total surface area of the varistor.

For most varistor types the maximum permissible body temperature is 125 °C.

ZINC-OXIDE VOLTAGE DEPENDENT RESISTORS

Unlike SiC types, the ZnO varistors are mainly intended for applications requiring intermittent power dissipation, i.e. transient suppression and contact arc prevention. In their transient suppression role, the symmetrical mode of operation allows them to be connected directly across a.c. power lines carrying r.m.s. voltages of 30 to 460 V (currently available types). They are capable of withstanding voltage or current pulses with a high peak energy level. A typical β for this type of varistor is 0,03. This means that, if the current through the varistor increases by a factor of 10 within the straight-line portion of the characteristic, the voltage across it increases by a factor of 1,07

A typical V/I characteristic for one of these varistors is shown in Fig. 9. The upward turn of the characteristic (decreasing non-linearity) is due to the increasing influence of the linear series resistance of the component as its non-linear resistance falls to very low values at extreme currents. A good approximation of the relationship between the voltage and the current in the curved portion of the characteristics is given by the expression:

$$V = CI^\beta + IR_s,$$

where R_s is the series resistance of the varistor.

See further the data sheets of the varistor series 2322 592, 2322 593, 2322 594 and 2322 595

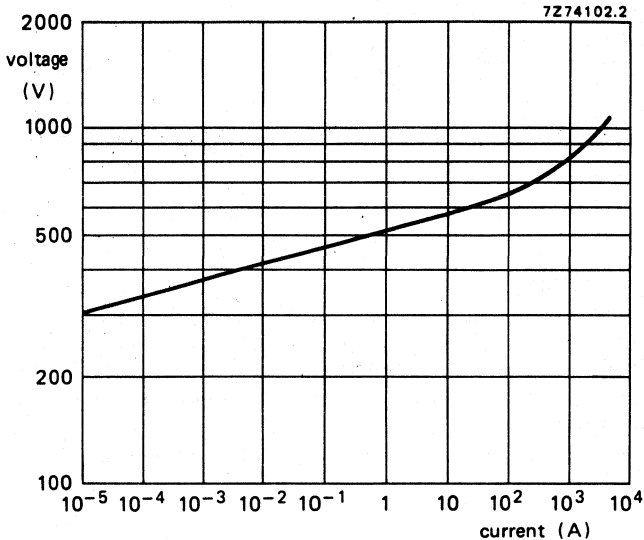

Fig. 9 Typical V/I characteristic of ZnO varistor 2322 595 62512 and 2322 595 62516 for 220 V mains supply.

Normal operating conditions of the ZnO varistor

Owing to the extreme nonlinearity of the voltage/current characteristic of ZnO varistors, and the necessity to allow a margin for the extra dissipation during a transient, ensure that the maximum voltage applied across the varistor during normal operation never attains such a value that the specified average dissipation limit of the varistor is approached. This will never be a problem if the varistor is selected according to the figures for max. r.m.s. voltage in the data sheet. The peak value of the sinusoidal voltage applied to the varistor must always be less than the minimum voltage specified at 1 mA. If the applied voltage is other than sinusoidal, the varistor should be selected on the basis of the specified maximum peak working voltage.

HOW TO MEASURE VARISTORS

The following points have to be considered when measuring varistors.

1. Use only d.c. voltage.
2. Keep the measuring time as short as possible. Self-heating effects may influence the measurements due to the negative temperature coefficient of the varistors.
3. When the varistors are specified at a voltage and current which is above the maximum dissipation, pulses should be used. For instance all zinc oxide types, which are for spike/transient suppression are measured under pulse-conditions. These types are measured with a standard pulse current $8/20 \mu\text{s}$ as defined in IEC 60-2, section 6.
4. The β -value measurement needs some explanation. As mentioned on page 309 the β -value is not always constant but depends on the voltage and current. The β -values of our discs are measured between 0,3 I and 3 I, those of our rods between 1 and 10 I (unless otherwise specified), where I is the current at which the varistor is specified. For example:

$$\beta = \log \frac{V_2}{V_1}; \text{ with } V_2 = \text{voltage at } 3 \text{ I,} \\ V_1 = \text{voltage at } 0,3 \text{ I.}$$

TOLERANCES

Standard varistors are specified with a certain tolerance on voltage and a spread on β -value. It can be seen in Fig. 10 that due to the spread in β -value the tolerance on voltage may increase at currents other than the specified current at which the varistor is measured.

For some applications, where tolerances have to be kept as low as possible, the varistors are measured at a current or voltage which lies near to its working point in the circuit, e.g. the standard rod types for relative high voltage stabilization series 2322 564 02 are measured at 10 mA.

For other applications, especially spark suppression, it is often important to specify the varistor at two points: a point at low current or low voltage and a point at high current or high voltage.

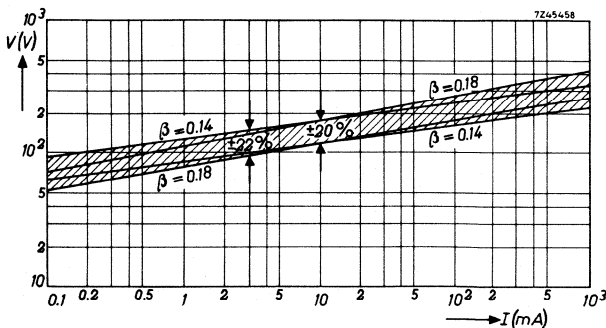

Fig. 10 Spread of voltage/current characteristic due to β -tolerance.

APPLICATIONS

Some of the most important application principles are given in the following pages. Well known television applications are the varistor used as a rectifier of non-symmetrical pulses, and for stabilization against supply voltage variations and aging of components. The varistor is also used in TV sets across the primary of the frame output transformer for damping oscillations, while in other circuits varistors fulfil the functions of voltage stabilization devices. Outside the entertainment field we find varistors used in telecommunications as relay contact protectors. A special range of varistors has been developed for this purpose. Similar application can be found in small battery motors where the varistor increases the commutator life considerably. There are many more uses for varistors and the following selection is by no means complete.

Contact-protection and spark suppression

Two principal circuits are used. As soon as the contacts open, the energy stored in the inductance ($\frac{1}{2}LI^2$) is dissipated by the varistor, limiting the voltage across the contacts to a safe value,

Zinc oxide varistors (2322 592/593/594/595 series) are designed especially for the suppression of voltage transients.

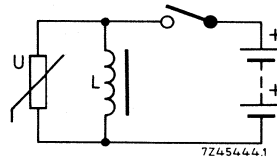
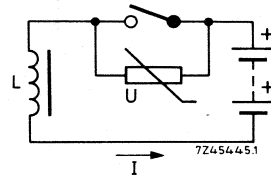

Protection of small battery motors

Sparking brush contacts limit the commutator life and give rise to interference with nearby radio or audio circuits. A small varistor in parallel to the rotor windings prevents the sparking and so increases the commutator life considerably.

Multi-segment discs are available for incorporation into the commutator construction.

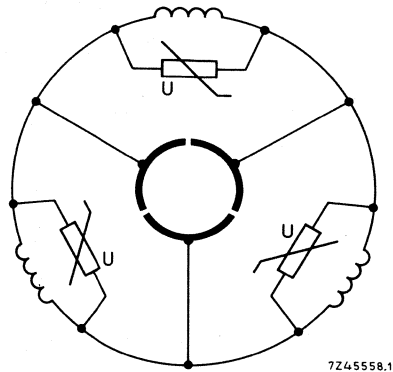

VARISTORS

Varistor for adapting meter sensitivity

A varistor in series with a voltmeter or in parallel with a milliammeter enables part of the scale to be expanded for more accurate reading of measurements.

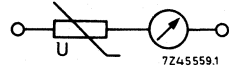

Stabilization of a voltage without load when the supply voltage varies

It can be shown that the varistor stabilizes varying supply voltages by a factor

$$S = \frac{\Delta V/V}{\Delta V_2/V_2} = \frac{1}{\beta} - \frac{1-\beta}{\beta} \cdot x, \text{ where } x = V_2/V.$$

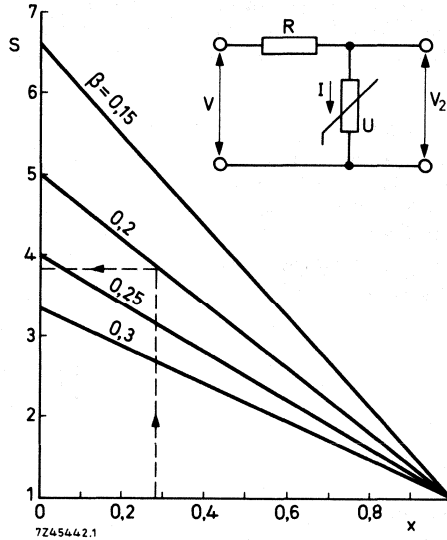

Stabilization of a voltage with load

$$S = \frac{1}{\beta} - \frac{1-\beta}{\beta} \cdot \frac{x+y}{1+y} \quad \text{where } x = V_2/V \text{ and } y = I_2/I_1.$$

The nomogram makes S easy to find.

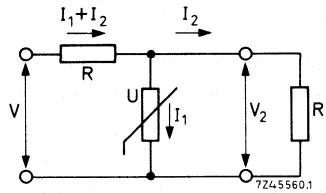
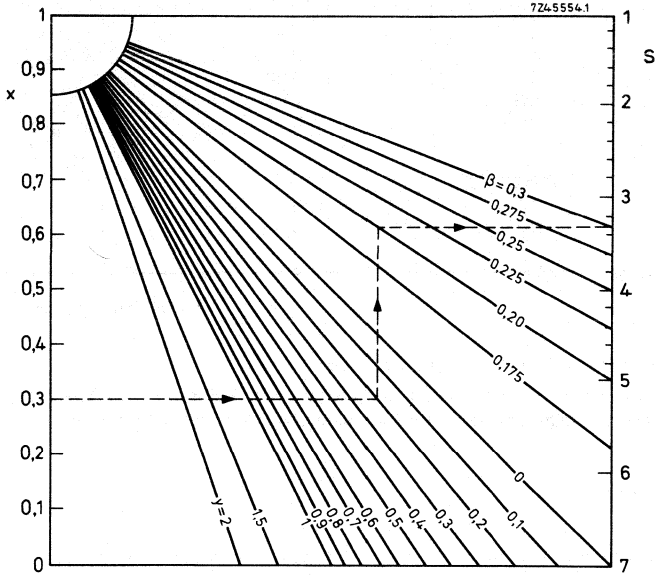

The silicon carbide varistors (2322 552 series) are particularly suited for stabilization of d.c. voltages.

Protection of a thyristor bridge in a washing machine

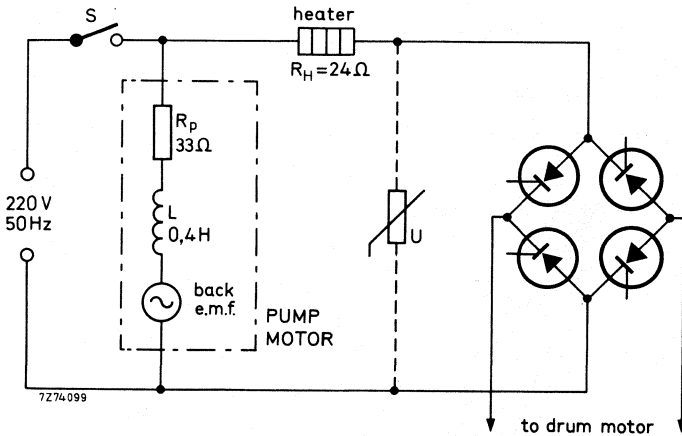

Behaviour of the circuit without varistor protection

The measured peak current through the pump motor when S is closed is 1 A. The energy expended in establishing the electromagnetic field in the inductance of the motor is therefore:

$$\frac{I^2 L}{2} = \frac{0,4}{2} = 200 \text{ mJ.}$$

Without varistor protection, an initial current of 1 A will flow through the thyristor bridge when S opens, and a voltage sufficient to damage or destroy the thyristors will be developed. Arcing will occur across the opening contacts of the switch.

Behaviour of the circuit with varistor 2322 593 62512

On opening switch S, the peak voltage developed across the varistor is:

$$V = C_{\max} I^\beta = 600 \text{ V.}$$

The thyristors in the bridge can withstand this voltage without damage.

The total energy returned to the circuit is 200 mJ. Of this 15,7 mJ are dissipated in the heater and 184,3 mJ are dissipated in the varistor. The varistor can withstand more than 10^5 transients containing this amount of energy.

Marking

A three-band colour code as shown in Fig. 1. This code indicates the three figures following the zero in the last part of the catalogue number shown in Table 1. The colours are in accordance with the standard varistor resistor colour code, e.g. type 2322 552 01161 is coded brown, brown, blue (100 mA, 8 V). See Table 2.

Mass

See Table 1.

Mounting

In any position by soldering.

Robustness of terminations

Tensile strength	20 N
Bending	10 N

Soldering

Resistance to heat max. 240 °C, max. 4 s

ELECTRICAL DATA

Tolerance on voltage at I_{nom}	± 20%
Maximum dissipation	0,8 W
Asymmetry	max. 2%
Operating temperature range	
zero power	-25 to +125 °C
max. power	0 to + 55 °C

See further Table 1.

PACKAGING

100 varistors in a cardboard box.

Table 1 Catalogue numbers 2322 552 0....

suffix of catalogue number 20% on V	d.c. current I_{nom} mA	voltage at I_{nom} V	β	C approx.	mass g	S max (Fig. 1) mm
1161	100	8	0,25 to 0,40	14	1,3	9
1181	100	10	0,25 to 0,40	18	1,3	9
1201	100	12	0,25 to 0,40	21	1,3	9
2161	10	8	0,25 to 0,40	25	1,3	9
2181	10	10	0,25 to 0,40	32	1,4	9
2201	10	12	0,25 to 0,40	40	1,4	9
2221	10	15	0,25 to 0,40	48	1,4	9
2241	10	18	0,21 to 0,35	57	1,45	9
2261	10	22	0,21 to 0,35	60	1,45	9
2281	10	27	0,21 to 0,35	70	1,45	9
2301	10	33	0,18 to 0,25	85	1,45	9
2321	10	39	0,18 to 0,25	100	1,45	9
2341	10	47	0,18 to 0,25	130	1,45	9
2361	10	56	0,18 to 0,25	150	1,45	9
2381	10	68	0,18 to 0,25	180	1,45	9
3361	1	56	0,14 to 0,23	190	1,45	9
3381	1	68	0,14 to 0,23	230	1,45	9
3401	1	82	0,14 to 0,21	300	1,5	9
3421	1	100	0,14 to 0,21	350	1,6	9
3441	1	120	0,14 to 0,21	400	1,65	9
3461	1	150	0,14 to 0,21	500	1,75	9
3481	1	180	0,14 to 0,21	600	1,9	10
3501	1	220	0,14 to 0,21	750	2,15	10
3521	1	270	0,14 to 0,21	900	2,3	10
3541	1	330	0,14 to 0,21	1100	2,6	10

Table 2.

varistor standard

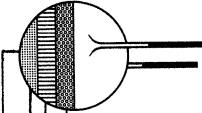

brown = 100 mA
red = 10 mA
orange = 1 mA

brown/blue = 8 V	orange/blue = 56 V
brown/grey = 10 V	orange/grey = 68 V
red/black = 12 V	yellow/black = 82 V
red/red = 15 V	yellow/red = 100 V
red/yellow = 18 V	yellow/yellow = 120 V
red/blue = 22 V	yellow/blue = 150 V
red/grey = 27 V	yellow/grey = 180 V
orange/black = 33 V	green/black = 220 V
orange/red = 39 V	green/red = 270 V
orange/yellow = 47 V	green/yellow = 330 V

untipped
20% tol.

VARISTORS

silicon carbide rod

QUICK REFERENCE DATA

D.C. voltage	
$I_{nom} = 10 \text{ mA}$	470 to 1300 V
$I_{nom} = 2 \text{ mA}$	950 V
$I_{nom} = 1 \text{ mA}$	300 V
β -values	0,16 to 0,25
Maximum dissipation	0,8 W
Operating temperature range	
zero power	-25 to +125 °C
max. power	0 to + 55 °C

APPLICATION

Voltage stabilization, contact protection, etc.

DESCRIPTION

A rod of silicon carbide with axial tinned copper leads. The rod is coated with tan coloured lacquer. It is not insulated.

MECHANICAL DATA

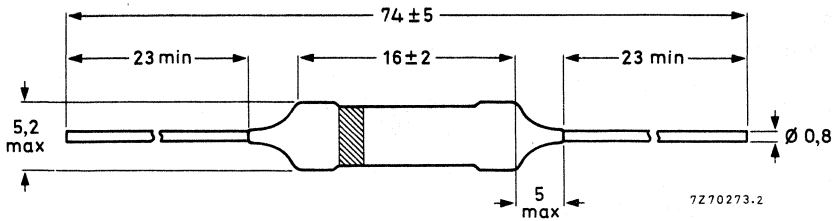

Fig. 1.

Marking

The thermistors are colour coded according to the table and Fig. 1.

Mass

0,9 g approximately

Mounting

In any position by soldering

2322 564 02...
2322 564 90...

Robustness of terminations

Tensile strength 20 N
Bending 10 N
Torsion 3 times

Soldering

Solderability max. 240 °C, max. 4 s
Resistance to heat max. 265 °C, max. 11 s

ELECTRICAL DATA

catalogue number	d.c. current I_{nom} mA	voltage at I_{nom} V*	tolerance on V %	β -value	colour code (see Fig. 1)
2322 564 02582	10	470	± 10	0,20-0,25	green
2322 564 02602	10	560	± 10	0,18-0,23	blue
2322 564 02622	10	680	± 10	0,18-0,23	violet
2322 564 02681	10	1200	± 20	0,17-0,22	grey
2322 564 02682	10	1200	± 10	0,17-0,22	brown
2322 564 90014	10	910	± 10	0,17-0,22	white
2322 564 90015	10	1300	± 10	0,16-0,21	red
2322 564 90016	1	300	± 20	0,18-0,25	yellow

Dissipation factor 20 mW/K
Temperature coefficient at 1 mA
between +25 and +100 °C -0,1%/K
Maximum dissipation 0,8 W
Asymmetry ** max. 2%
Operating temperature range
at zero power -25 to +125 °C
at maximum power 0 to + 55 °C

PACKAGING

250 varistors in a cardboard box.

* The voltage is so measured, that the internal heat development is negligible.

** Covered by the specified voltage tolerance.

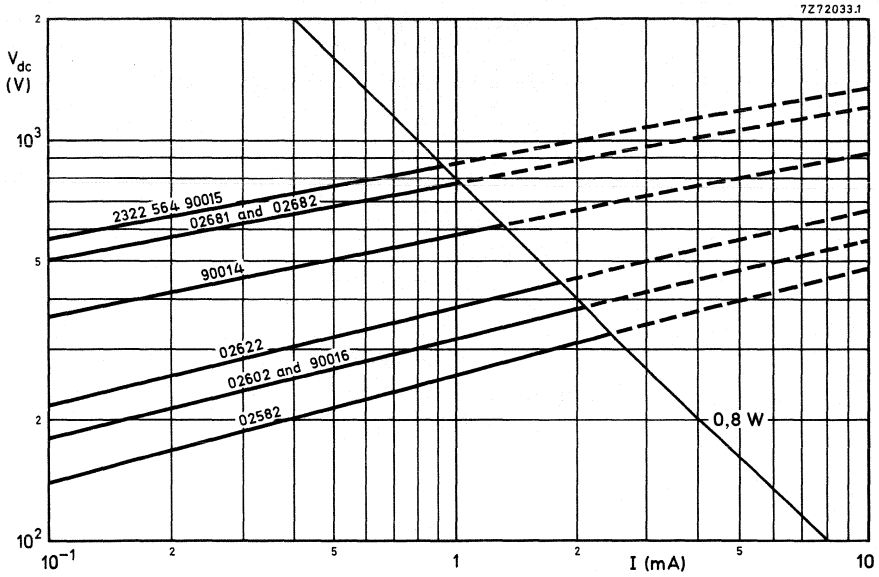
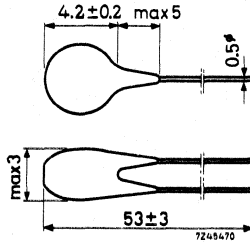

Fig. 2 Voltage/current characteristics.

VARISTORS

small silicon carbide disc types for special purposes



These varistors feature low capacitance and are for use in colour television and for protection of aerial inputs of car radios.

Current at 5 V d.c.

≤ 1 mA

Current at 28 V d.c.

≥ 10 mA

W_{max}

0,1 W

I mA	E V	tolerance on voltage	colour dip code	catalogue number
1	9	± 20%	orange	2322 565 90003
1	18	± 12%	blue	2322 565 90006

VARISTORS

zinc oxide disc, epoxy coated

QUICK REFERENCE DATA

Max. a.c. voltage (r.m.s.)	30 to 460 V
Max. d.c. voltage	38 to 615 V
Max. non-repetitive transient current (8/20 μ s)	100 to 4500 A
Climatic category	40/125/56
Specification	based on CECC 42000
Packaging	
2322 592 and 593	on tape on reel and bulk
2322 594 and 595	in bulk

APPLICATION

Suppression of transients to increase contact life and to improve electronic equipment reliability.

DESCRIPTION

These varistors consist of a disc of low- β ceramic material with two tinned solid copper wires. They are epoxy coated with layers of ochre-coloured epoxy which provides electrical, mechanical and climatic protection. The encapsulation is resistant to all cleaning solvents according to IEC 68-2-45.

MECHANICAL DATA

Outlines

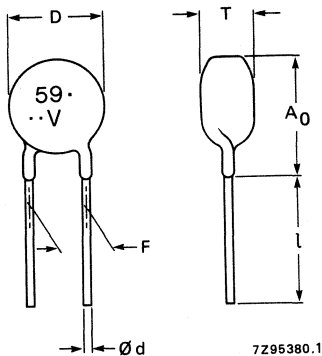

Table 1 Dimensions in mm (Fig. 1)

Series	D max.	T max.	A ₀ max.	l min.	d ± 10%	F
2322 592	7	7	11	20	0,6	5 ^{+0,8} -0,2
2322 593	9	7	13	19	0,6	5 ^{+0,8} -0,2
2322 594	12,5	7	16	17	0,8	7,62 ± 1
2322 595	16	7	19	16	0,8	7,62 ± 1

Mass : 2322 592 series : approx. 0,5 g
 2322 593 series : approx. 0,7 g
 2322 594 series : approx. 1,5 g
 2322 595 series : approx. 2 g

2322 592 to 595 EPOXY SERIES

Mounting

The varistors 592 and 593 are suitable for processing on automatic insertion equipment and cutting and bending machines.

Soldering

Solderability max. 240 °C, max. 4 s
Resistance to heat max. 265 °C, max. 11 s

Impact

free fall 1000 mm

Robustness of terminations

Tensile strength 10 N
Bending 5 N

Inflammability un inflammable

Marking

The varistors are marked with their series number (592, 593, 594 or 595), the manufacturer's logo and the maximum continuous r.m.s. voltage

Packaging and catalogue numbers

Table 3

catalogue number	packing	quantity	fig.
2322 592 0...6	on reel	1500	3, 4
2322 592 5...6	bulk	500	1
2322 593 0...6	on reel	1500	3, 4
2322 593 5...6	bulk	500	1
2322 594 5...6	bulk	250	1
2322 595 5...6	bulk	250	1

To complete the catalogue number the dots must be replaced by digits as per Table 2, referring to the r.m.s. voltage.

ELECTRICAL DATA, see also Table 2 and subsequent curves.

Climatic category 40/125/56
Insulation voltage 2500 V
Temperature coefficient of voltage at 1 mA max. -0,065 %/K

Derating see Fig. 2.

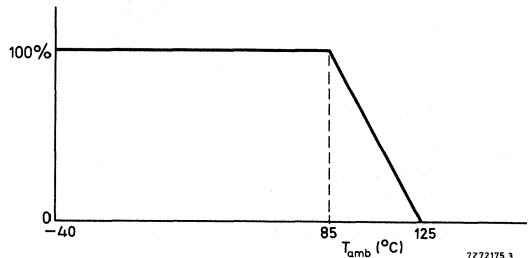

Fig. 2 Derating of max. d.c. and r.m.s. working voltage with temperature.

7272175.3

Table 2

catalogue number * 2322 followed by	maximum continuous voltage		voltage at 1 mA		max. voltage at current (8x20 μs)		max. energy (10x1000 μs)	max. non rep. surge current (8x20 μs)	typical capacitance at 1 KHz
	V (r.m.s.)	V (d.c.)	V (min.)	V (max.)	V	A			
592 . 3006	30	38	42	52	96	1	J	100	1000
593 . 3006					93	2,5	0,8	250	2000
594 53006					93	5	1,5	500	4000
595 53006					90	10	3,1	1000	6500
592 . 3506	35	45	50	62	123	1	0,6	100	850
593 . 3506					115	2,5	1,0	250	1500
594 53506					110	5	2,1	500	3000
595 53506					105	10	3,8	1000	5000
592 . 4006	40	56	61	75	145	1	0,8	100	700
593 . 4006					135	2,5	1,3	250	1200
594 54006					130	5	2,5	500	2400
595 54006					130	10	5,0	1000	4000
592 . 5006	50	65	74	90	145	5	2,4	400	500
593 . 5006					140	10	4,1	1200	1000
594 55006					140	25	6,5	2500	2200
595 55006					140	50	10,5	4500	3700
592 . 6006	60	85	90	110	165	5	2,7	400	330
593 . 6006					165	10	4,6	1200	600
594 56006					165	25	8	2500	1200
595 56006					165	50	12	4500	2300
592 . 7506	75	100	108	132	190	5	3,5	400	270
593 . 7506					200	10	5,5	1200	530
594 57506					200	25	10	2500	1000
595 57506					200	50	14	4500	1900

* For composition of the code number see table 3.

Table 2 (continued)

catalogue number *	maximum continuous voltage		voltage at 1 mA		max. voltage at current (8x20 μs)		max. energy (10x1000 μs)	max. non rep. surge current (8x20 μs)	typical capacitance at 1 KHz
	V (r.m.s.)	V (d.c.)	V (min.)	V (max.)	V	A			
2322 followed by									
592 . 9506		125	135	165	230	5	4	400	220
593 . 9506	95				250	10	7	1200	460
594 . 9506					250	25	12	2500	900
595 . 9506					250	50	19	4500	1700
592 . 1316									
593 . 1316	130	170	185	225	310	5	5.5	400	150
594 . 1316					340	10	9.5	1200	390
595 . 1316					340	25	16	2500	730
					380	50	26	4500	1300
592 . 1516									
593 . 1516	150	200	216	264	395	5	6.5	400	130
594 . 1516					400	10	11	1200	340
595 . 1516					400	25	18	2500	600
					400	50	30	4500	1100
592 . 1716									
593 . 1716	175	225	247	303	410	5	7	400	110
594 . 1716					455	10	13	1200	250
595 . 1716					455	25	22	2500	480
					455	50	35	4500	920
592 . 2316									
593 . 2316	230	300	324	396	560	5	9	400	90
594 . 2316					600	10	16	1200	190
595 . 2316					600	25	29	2500	360
					600	50	48	4500	700
592 . 2516									
593 . 2516	250	320	351	429	600	5	10	400	80
594 . 2516					650	10	18	1200	160
595 . 2516					650	25	32	2500	320
					650	50	51	4500	630

* For composition of the code number see table 3.

Table 2 (continued)

catalogue number *	maximum continuous voltage		voltage at 1 mA		max. voltage at current (8x20 μs)		max. energy (10x1000 μs)	max. non. rep. surge current 8x20 μs)	typical capacitance at 1 KHz
	V (r.m.s.)	V (d.c.)	V (min.)	V (max.)	V	A			
2322 followed by									
592 . 2716					695	5	11	400	80
593 . 2716	275	350	387	473	710	10	20	1200	140
594 52716					710	25	35	2500	290
595 52716					710	50	56	4500	600
592 . 3016					750	5	12	400	70
593 . 3016	300	385	423	517	800	10	22	1200	110
594 53016					800	25	38	2500	240
595 53016					800	50	61	4500	520
592 . 4216					1100	5	17	400	60
593 . 4216	420	560	612	748	1120	10	30	1200	90
594 54216					1120	25	54	2500	190
595 54216					1120	50	93	4500	400
592 . 4616					1200	5	20	400	50
593 . 4616	460	615	675	825	1250	10	32	1200	80
594 54616					1240	25	59	2500	170
595 54616					1240	50	102	4500	380

* For composition of the code number see table 3.

Dimensions of tape

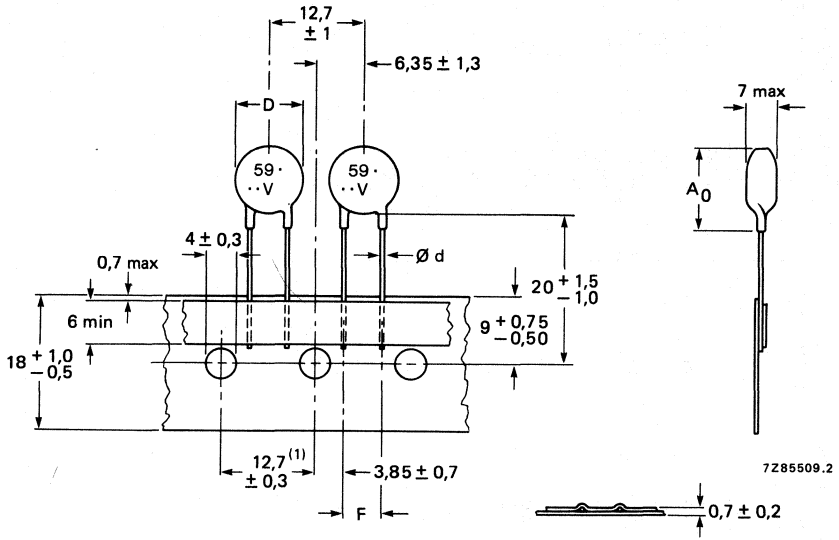

Fig. 3 Dimensions of bandolier, for dimensions of D, d, A₀ and F see Table 1.

(1) Cumulative pitch error: 1 mm/20 pitch.

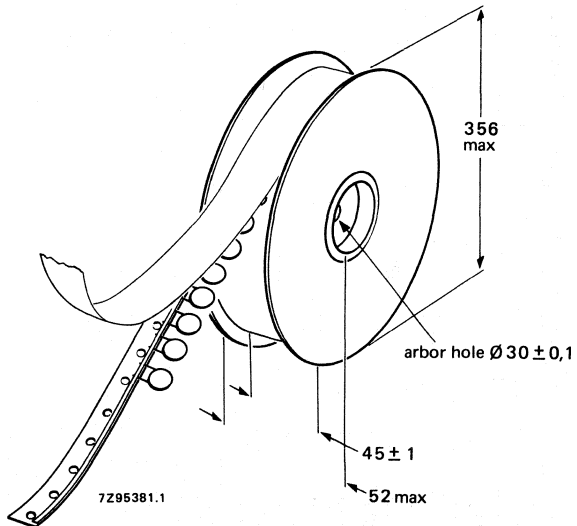

Fig. 4 Dimensions of reel.

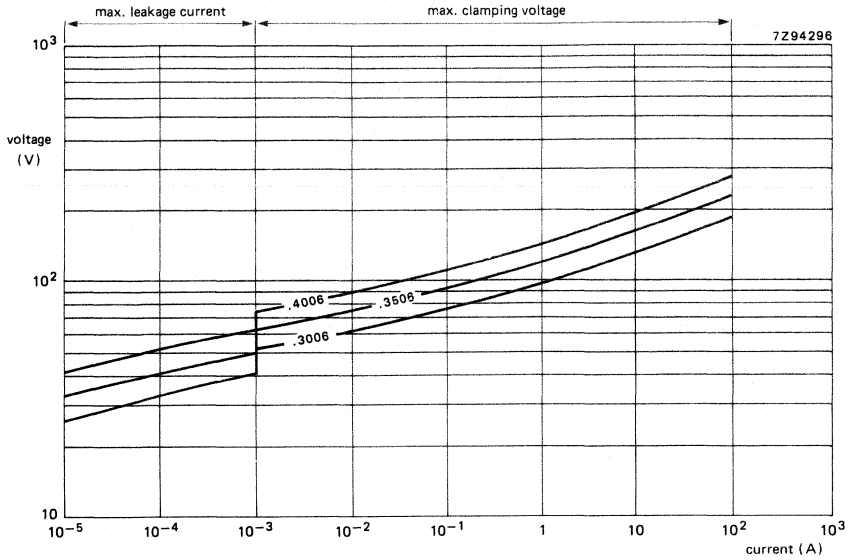

Fig. 5 V/I characteristics, 30/40 V, 592 series.

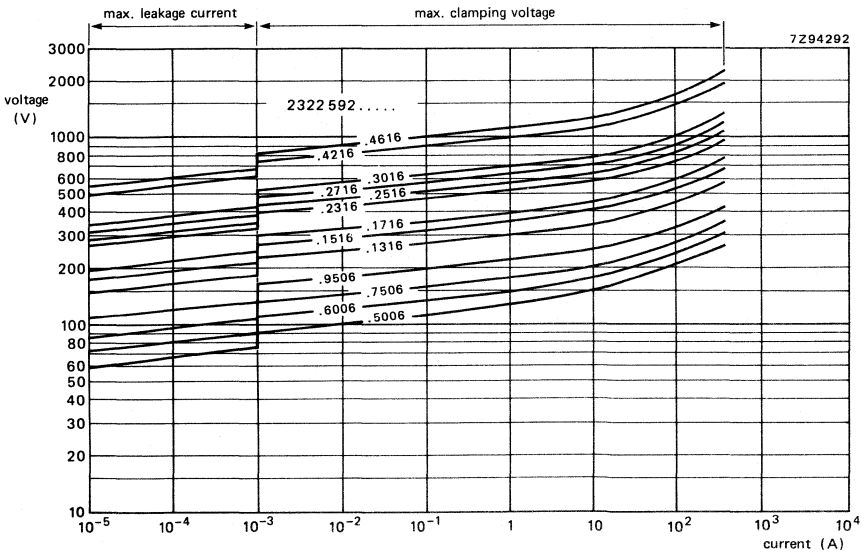

Fig. 6 V/I characteristics, 50/460 V, 592 series.

2322 592 to 595
EPOXY SERIES

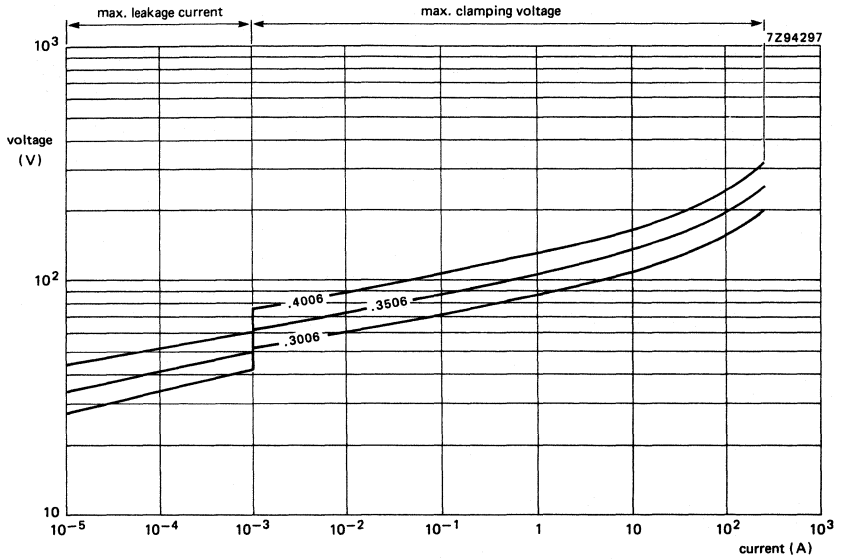

Fig. 7 V/I characteristics, 30/40 V, 593 series.

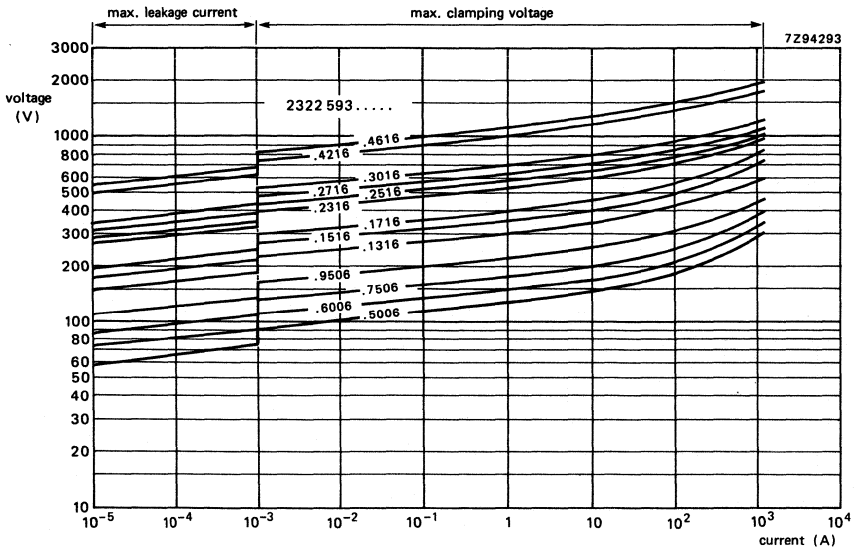

Fig. 8 V/I characteristics, 50/460 V, 593 series.

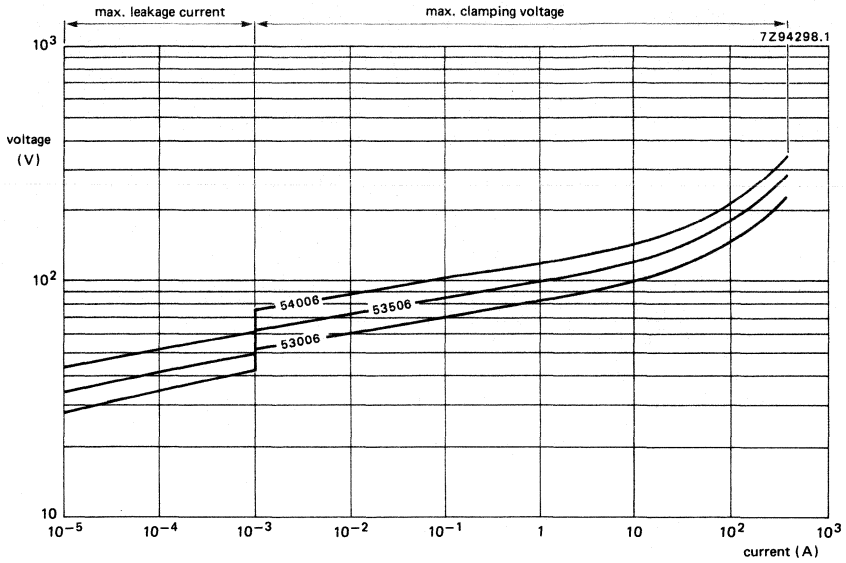

Fig. 9 V/I characteristics, 30/40 V, 594 series.

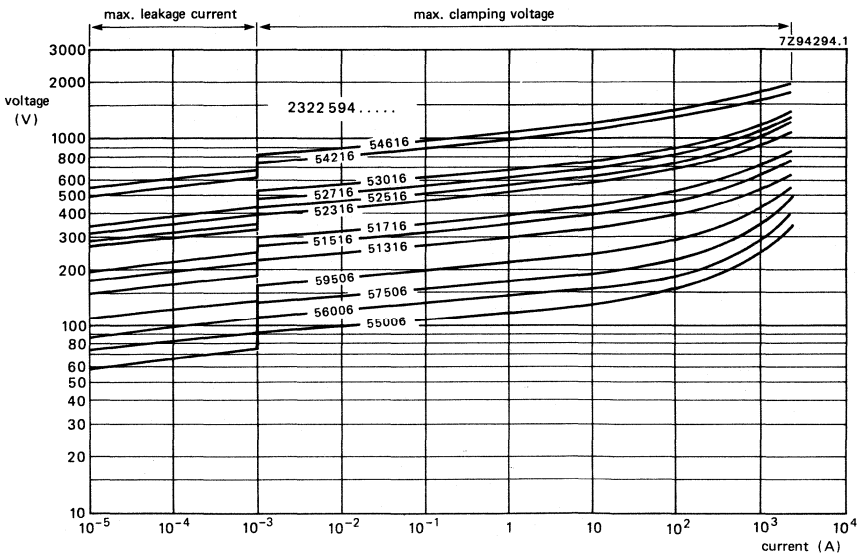

Fig. 10 V/I characteristics, 50/460 V, 594 series.

2322 592 to 595
EPOXY SERIES

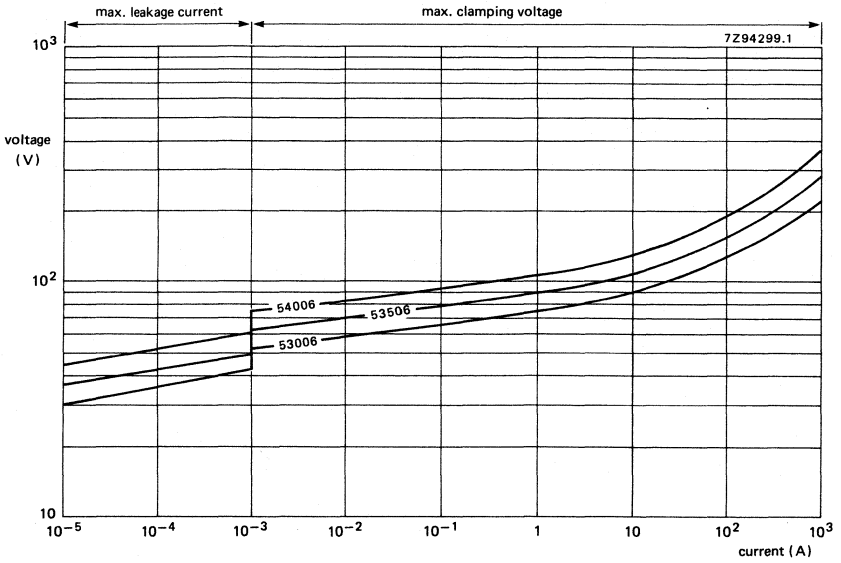

Fig. 11 V/I characteristics, 30/40 V, 595 series.

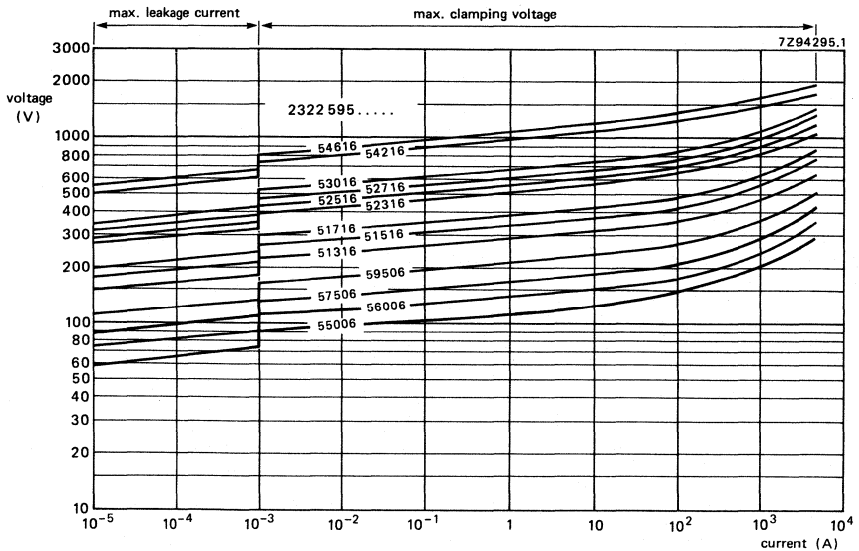

Fig. 12 V/I characteristics, 50/460 V, 595 series.

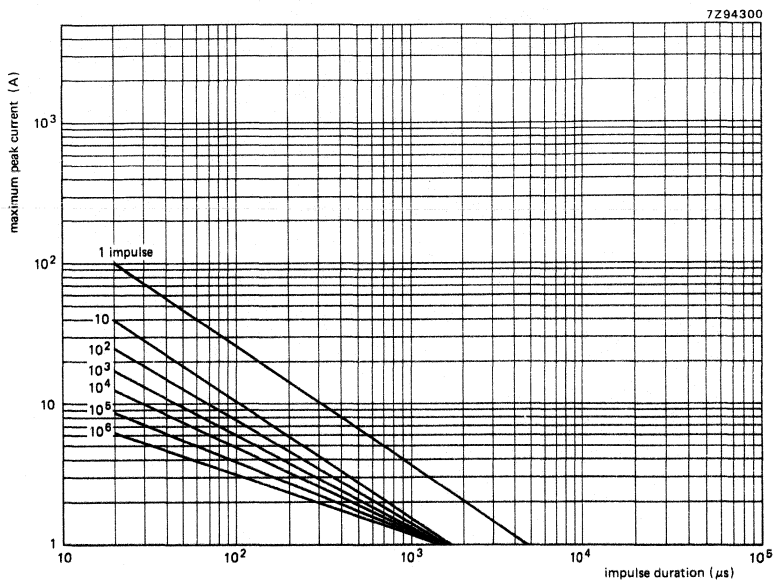

Fig. 13 Max. applicable transient current as a function of impulse duration, 30/40 V, 592 series.

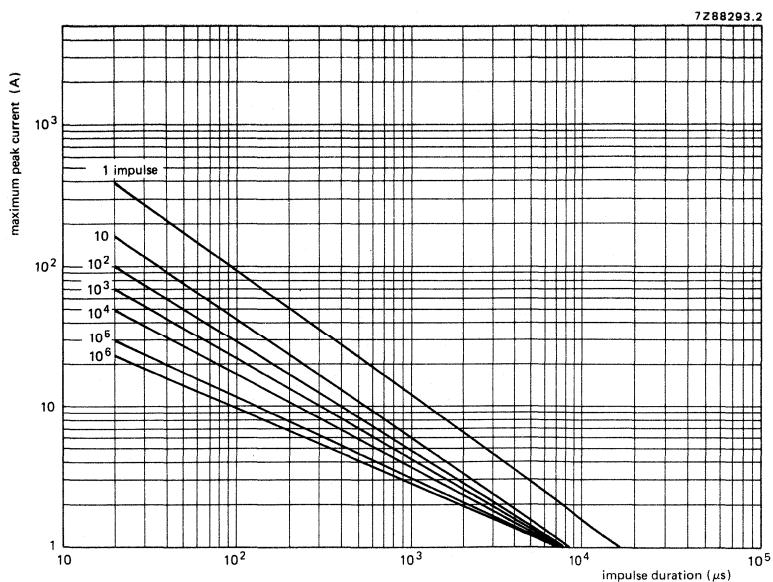

Fig. 14 Max. applicable transient current as a function of impulse duration, 50/460 V, 592 series.

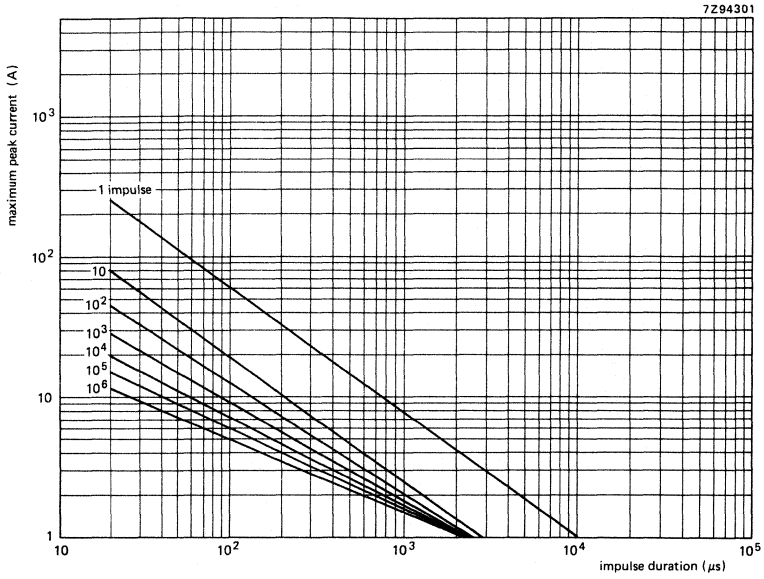

Fig. 15 Max. applicable transient current as a function of impulse duration, 30/40 V, 593 series.

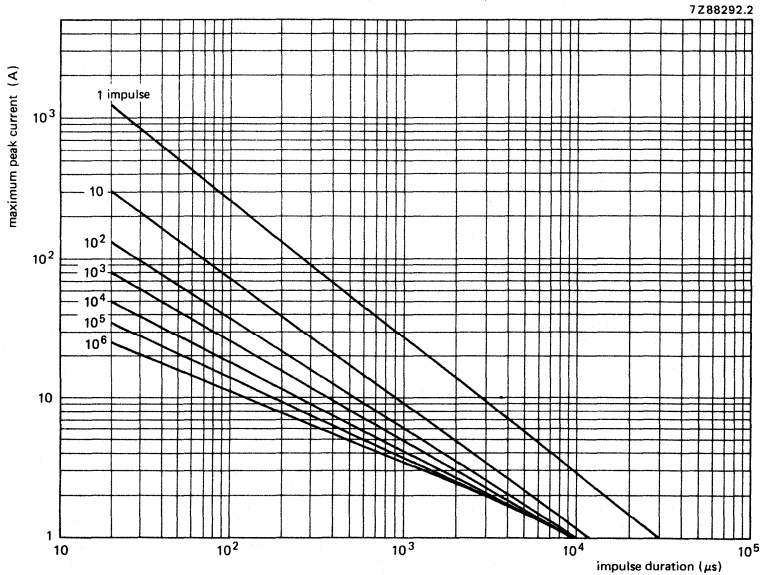

Fig. 16 Max. applicable transient current as a function of impulse duration, 50/460 V, 593 series.

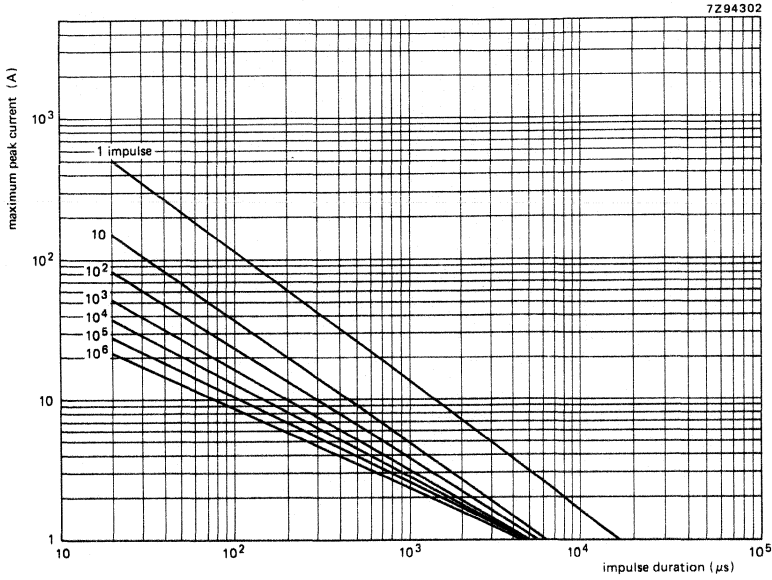

Fig. 17 Max. applicable transient current as a function of impulse duration, 30/40 V, 594 series.

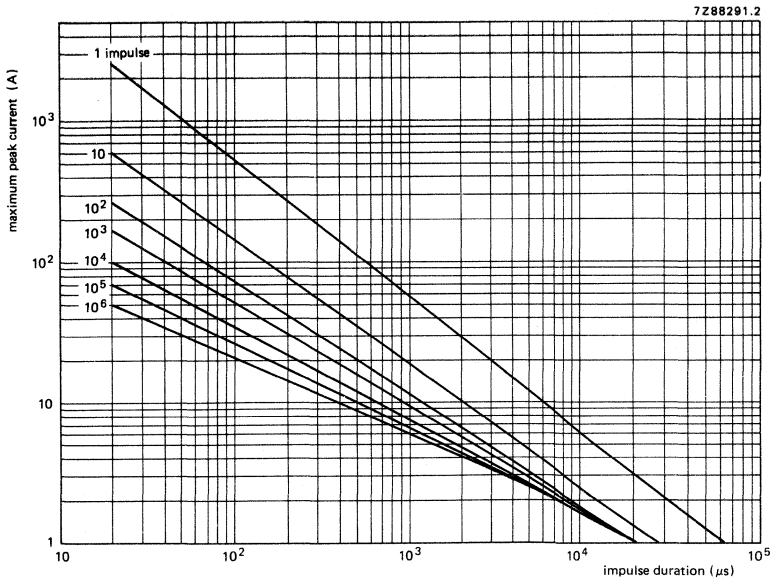

Fig. 18 Max. applicable transient current as a function of impulse duration, 50/460 V, 594 series.

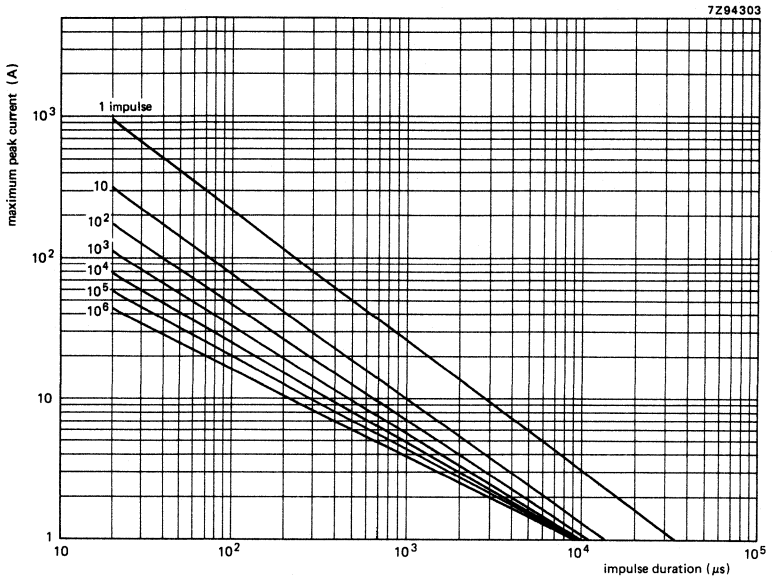

Fig. 19 Max. applicable transient current as a function of impulse duration, 30/40 V, 595 series.

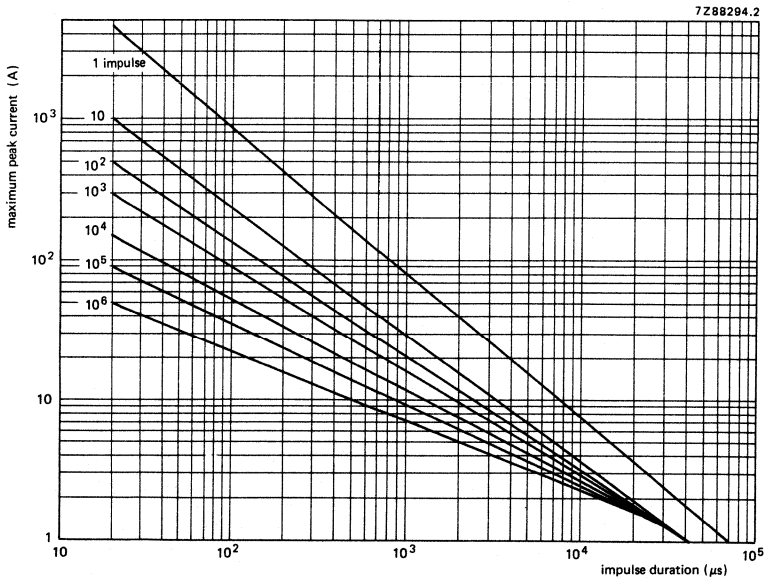

Fig. 20 Max. applicable transient current as a function of impulse duration, 50/460 V, 595 series.

VARISTORS

zinc oxide disc

QUICK REFERENCE DATA

Maximum a.c. voltage (r.m.s.)	60 to 460 V
Maximum d.c. voltage	85 to 615 V
Maximum non-repetitive transient current (8/20 μ s)	400 A
Climatic category	40/125/56
Packaging	
2322 592 3...2	in tape on reel
2322 592 6...2	in bulk in box

APPLICATION

Suppression of transients, contact protection, spark suppression, suppression of line transients in telephony.

DESCRIPTION

A disc of low- β ceramic with two solid tinned copper wires. These varistors are white lacquered, but not insulated.

MECHANICAL DATA

Outlines

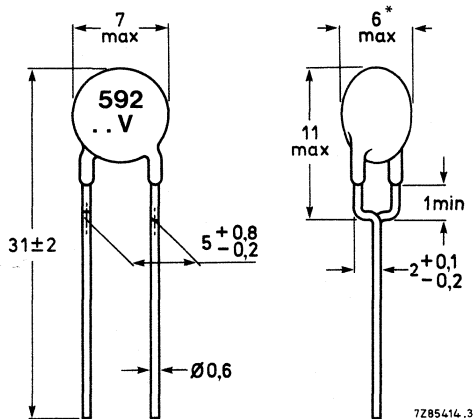

Fig. 1.

* The device thickness is dependent upon the r.m.s. working voltage rating.

Marking

The resistors are marked with their serial number (592) and the maximum r.m.s. working voltage (see Fig. 1 and Table 1).

Mass

Approx. 0,5 g.

Mounting

In any position by soldering. Leads should be as short as possible. The varistors should be mounted near the equipment or component to be protected. Taped product is available for automatic insertion.

Robustness of terminations

Tensile strength	10 N
Bending	5 N

Soldering

Solderability	max. 240 °C, max. 4 s
Resistance to heat	260 ± 5 °C; 10 ± 1 s

Inpact

Free fall	1000 mm
-----------	---------

Resistance to solvents

According to IEC 68-2-45, resist to R113

Inflammability

Self-extinguishing according to IEC draft 50D, severity 10 s

ELECTRICAL DATA

Unless otherwise specified all electrical values apply at an ambient temperature of $+23 \pm 1$ °C

Thermal resistance, body to air	approx.	80 K/W
Temperature coefficient at 1 mA, measured between +25 and +85 °C	max.	-0,065 %/K
Maximum average dissipation (including transients)		100 mW
Maximum non-repetitive transient current (8/20 μ s) (note 5)		400 A
Climatic category		40/125/56

See further Table 1

Table 1 Catalogue numbers 2322 592 3... and 2322 592 6...

suffix of catalogue number	MAXIMUM RATINGS				CHARACTERISTICS			
	r.m.s. working voltage (notes 3, 4)	d.c. working voltage (note 3)	transient energy (notes 5, 6)		varistor voltage $\pm 10\%$ (note 1)		maximum clamping voltage at 50 A (note 2)	typical capacitance at 1 kHz
			8/20 μs	10/1000 μs	min.	max.		
	V	V	J	J	V	V	V	pF
6002	60	85	2,3	2,7	90	110	220	330
7502	75	100	2,6	3,5	108	132	240	270
9502	95	125	3,0	4,0	135	165	295	220
1312	130	170	4,5	5,5	185	225	405	150
1512	150	200	5,0	6,5	216	264	470	130
1712	175	225	5,5	7,0	243	297	525	110
2312	230	300	7,0	9,0	324	396	675	90
2512	250	320	7,5	10,0	351	429	745	80
2712	275	350	8,5	11,0	387	473	820	80
3012	300	385	9,5	12,0	423	517	905	70
4212	420	560	14,0	17,0	612	748	1340	60
4612	460	615	16,0	20,0	675	825	1480	50

Notes

- Voltage at a current of 1 mA, after an impulse time of 50 ms with a rise time of 10 μs to 1 ms.
- Measured with a standard impulse current 8/20 μs , defined in IEC 60-2 section 6, par. 16-1.
- Derating, see Fig. 4.
- Sinusoidal voltage assumed. For a non-sinusoidal voltage, the crest voltage $\times 0,707$ should be used for type selection.
- A current impulse of 8/20 μs (defined in IEC 60-2 section 6) is used as a standard for impulse current and clamping voltage ratings. The transient energy is given for one impulse applied during the life of the component. Figure 3 gives the derating for different numbers and longer duration of impulses. The shift of the varistor voltage does not exceed $\pm 5\%$.
- High energy surges are generally of longer duration. The max. energy for 1 impulse 10/1000 μs is given as a reference for long duration impulses. This impulse can be characterized by peak current I_p and impulse width t_2 (virtual time to half I_p value, defined in IEC 60-2 section 6), see Fig. 5. If V_p is the clamping voltage corresponding to I_p , the energy absorbed in the VDR is determined by equation $E = K \cdot V_p \cdot I_p \cdot t_2$; K depends on t_2 . When t_1 is 8 to 10 μs and $t_2 = 20 \mu\text{s}$, $K = 1$; when $t_2 = 50 \mu\text{s}$, $K = 1,2$; when $t_2 = 100 \mu\text{s}$, $K = 1,3$; when $t_2 = 1000 \mu\text{s}$, $K = 1,4$.

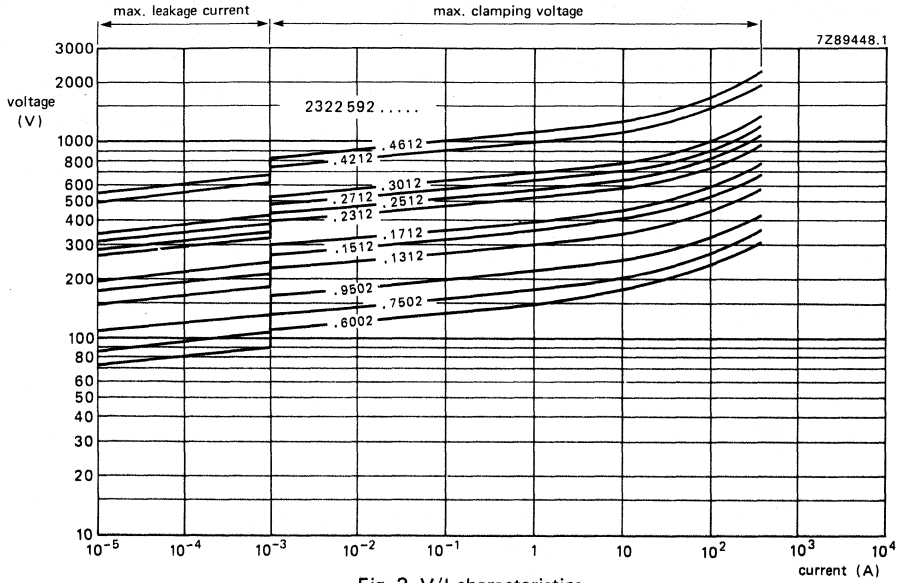

Fig. 2 V/I characteristics.

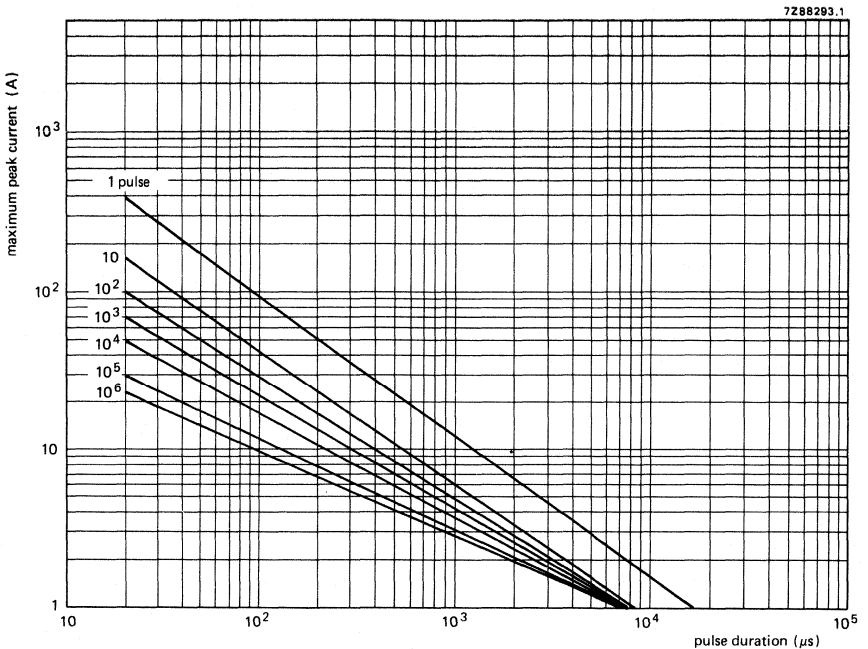

Fig. 3 Max. applicable transient current as a function of pulse duration.

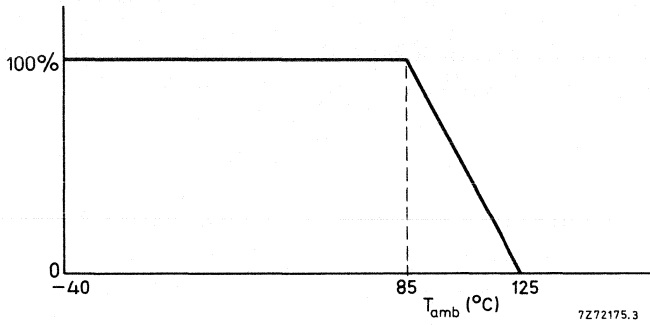

Fig. 4 Derating of max. d.c. and r.m.s. working voltage with temperature.

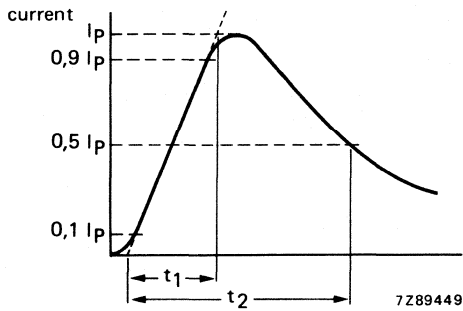

Fig. 5.

2322 592 3...2
 2322 592 6...2

PACKAGING

Types 2322 592 3...2 are supplied on tape on reel. A reel contains 1500 resistors.
 Types 2322 592 6...2 are supplied in bulk, 500 resistors per cardboard box.
 Configuration of the tape

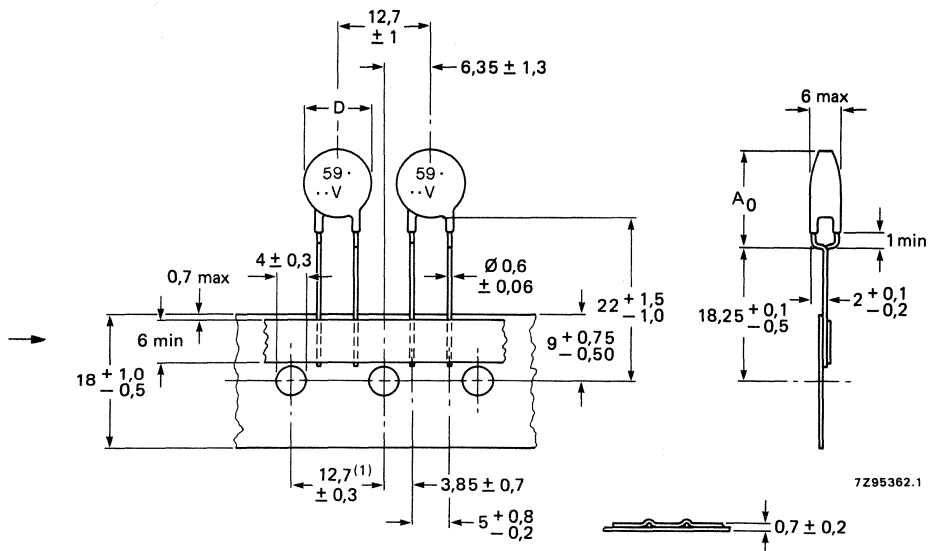

Fig. 6 Types 2322 592 3...2 on tape, $D = 7$ max, $A_0 = 11$.

(1) Cumulative pitch error: 1 mm/20 pitch.

VARISTORS

zinc oxide disc

QUICK REFERENCE DATA

Maximum a.c. voltage (r.m.s.)	60 to 460 V
Maximum d.c. voltage	85 to 615 V
Maximum non-repetitive transient current (8/20 μ s)	1200 A
Climatic category	40/125/56
Packaging	
2322 593 3...2	in tape on reel
2322 593 6...2	in bulk in box

APPLICATION

Suppression of transients, contact protection, spark suppression, suppression of line transients in telephony.

DESCRIPTION

A disc of low- β ceramic with two solid tinned copper wires. These varistors are white lacquered, but not insulated.

MECHANICAL DATA

Outlines

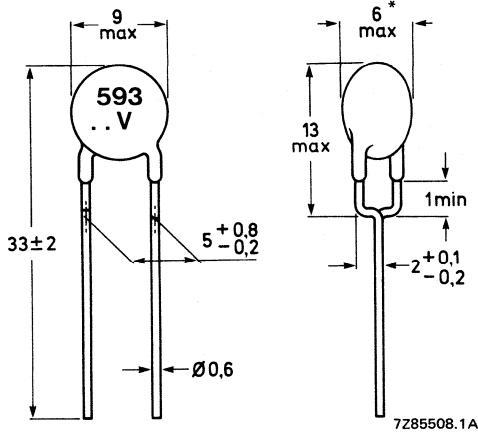

Fig. 1.

* The device thickness is dependent upon the r.m.s. working voltage rating.

Marking

The resistors are marked with their serial number (593) and the maximum r.m.s. working voltage (see Fig. 1 and Table 1).

Mass

Approx. 0,7 g

Mounting

In any position by soldering. Leads should be as short as possible. The varistors should be mounted near the equipment or component to be protected.

Robustness of terminations

Tensile strength 10 N
Bending 5 N

Soldering

Solderability max. 240 °C, max. 4 s
Resistance to heat 260 ± 5 °C; 10 ± 1 s

Impact

Free fall 1000 mm

Resistance to solvents

According to IEC 68-2-45, resist to R113 at 23 °C

Inflammability

Self-extinguishing according to IEC 50D, severity 10 s

ELECTRICAL DATA

Unless otherwise specified all electrical values apply at an ambient temperature of +23 ± 1 °C

Thermal resistance, body to air	approx.	70 K/W
Temperature coefficient at 1 mA, measured between +25 and +85 °C	max.	-0,065 %/K
Maximum average dissipation (including transients)		250 mW
Maximum non-repetitive transient current (8/20 μs) (note 5)		1200 A
Climatic category		40/125/56

See further Table 1

Table 1 Catalogue numbers 2322 593 3...and 2322 593 6...

suffix of catalogue number	MAXIMUM RATINGS				CHARACTERISTICS			
	r.m.s. working voltage (notes 3, 4)	d.c. working voltage (note 3)	transient energy (notes 5, 6)		varistor voltage $\pm 10\%$ (note 1)		maximum clamping voltage at 100 A (note 2)	typical capacitance at 1 kHz
			8/20 μs	10/1000 μs	min.	max.		
	V	V	J	J	V	V	V	pF
6002	60	85	6	4,6	90	110	210	600
7502	75	100	9	5,5	108	132	250	530
9502	95	125	9,5	7,0	135	165	310	460
1312	130	170	14	9,5	185	225	425	390
1512	150	200	17	11,0	216	264	485	340
1712	175	225	20	13,0	243	297	550	250
2312	230	300	22	16,0	324	396	720	190
2512	250	320	23	18,0	351	429	780	160
2712	275	350	26	20,0	387	473	850	140
3012	300	385	29	22,0	423	517	930	110
4212	420	560	42	30,0	612	748	1350	90
4612	460	615	48	32,0	675	825	1490	80

Notes

1. Voltage at a current of 1 mA, after an impulse time of 50 ms with a rise time of 10 μs to 1 ms.
2. Measured with a standard impulse current 8/20 μs , defined in IEC 60-2 section 6, par. 16-1.
3. Derating, see Fig. 4.
4. Sinusoidal voltage assumed. For a non-sinusoidal voltage, the crest voltage $\times 0,707$ should be used for type selection.
5. A current impulse of 8/20 μs (defined in IEC 60-2 section 6) is used as a standard for impulse current and clamping voltage ratings. The transient energy is given for one impulse applied during the life of the component. Figure 3 gives the derating for different numbers and longer duration of impulses. The shift of the varistor voltage does not exceed $\pm 5\%$.
6. High energy surges are generally of longer duration. The max. energy for 1 impulse 10/1000 μs is given as a reference for long duration impulses. This impulse can be characterized by peak current I_p and impulse width t_2 (virtual time to half I_p value, defined in IEC 60-2 section 6), see Fig. 5. If V_p is the clamping voltage corresponding to I_p , the energy absorbed in the VDR is determined by equation $E = K \cdot V_p \cdot I_p \cdot t_2$; K depends on t_2 . When t_1 is 8 to 10 μs and $t_2 = 20 \mu\text{s}$, $K = 1$; when $t_2 = 50 \mu\text{s}$, $K = 1,2$; when $t_2 = 100 \mu\text{s}$, $K = 1,3$; when $t_2 = 1000 \mu\text{s}$, $K = 1,4$.

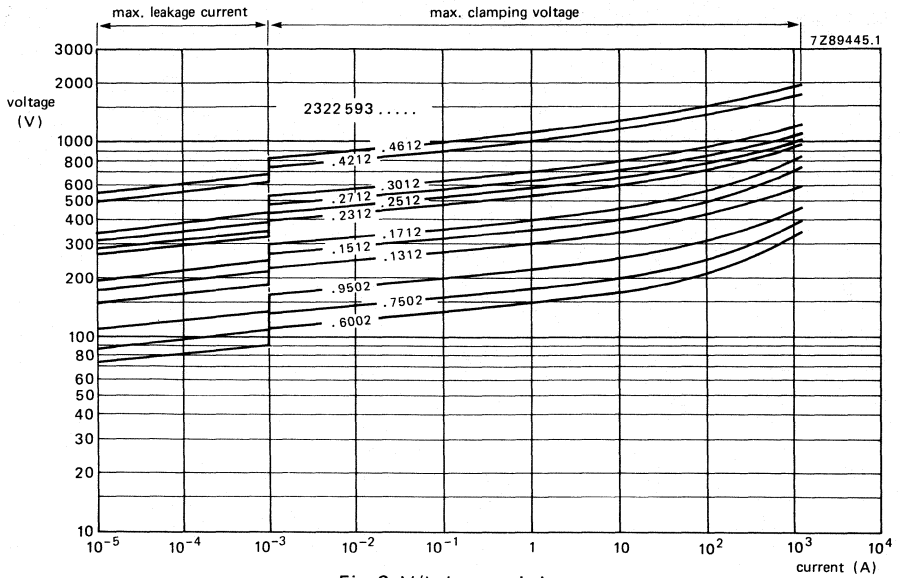

Fig. 2 V/I characteristics.

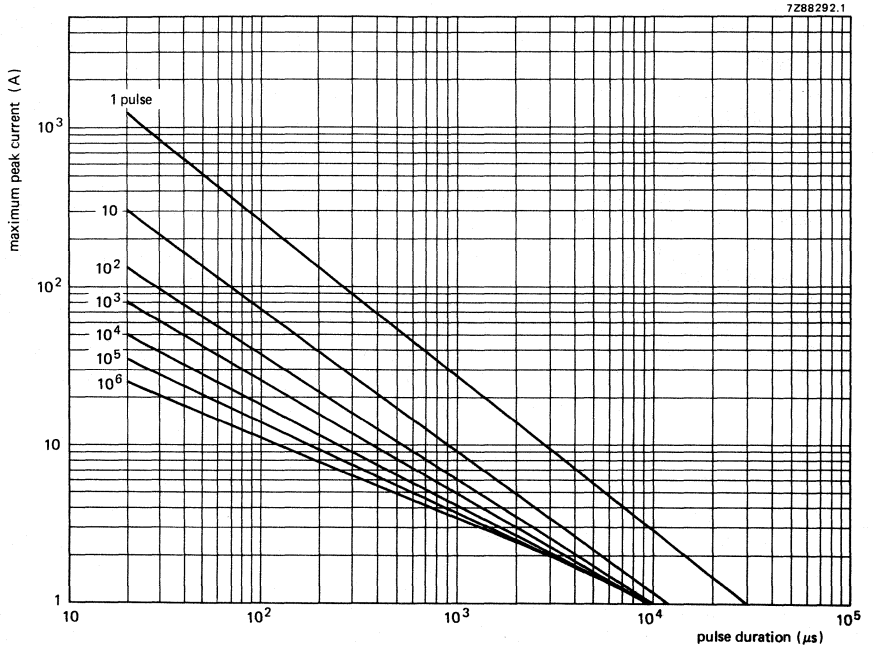

Fig. 3 Max. applicable transient current as a function of pulse duration.

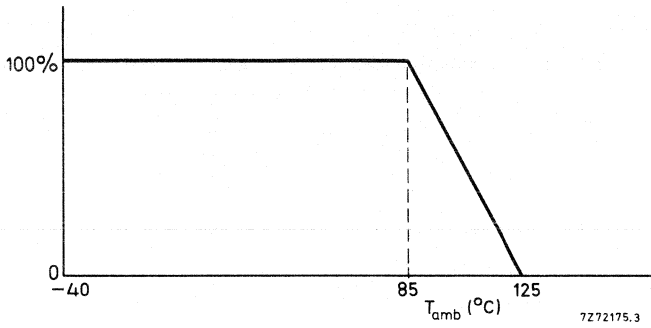

Fig. 4 Derating of max. d.c. and r.m.s. working voltage with temperature.

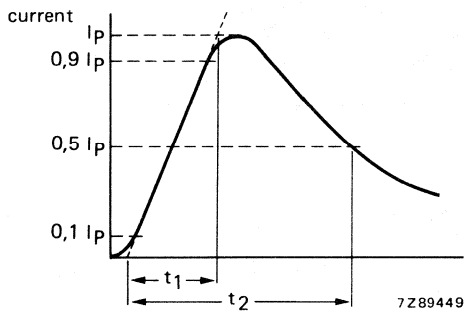

Fig. 5.

PACKAGING

Types 2322 593 3...2 are supplied on tape on reel. A reel contains 1500 resistors.
 Types 2322 593 6...2 are supplied in bulk, 500 resistors per cardboard box.

Configuration of the tape

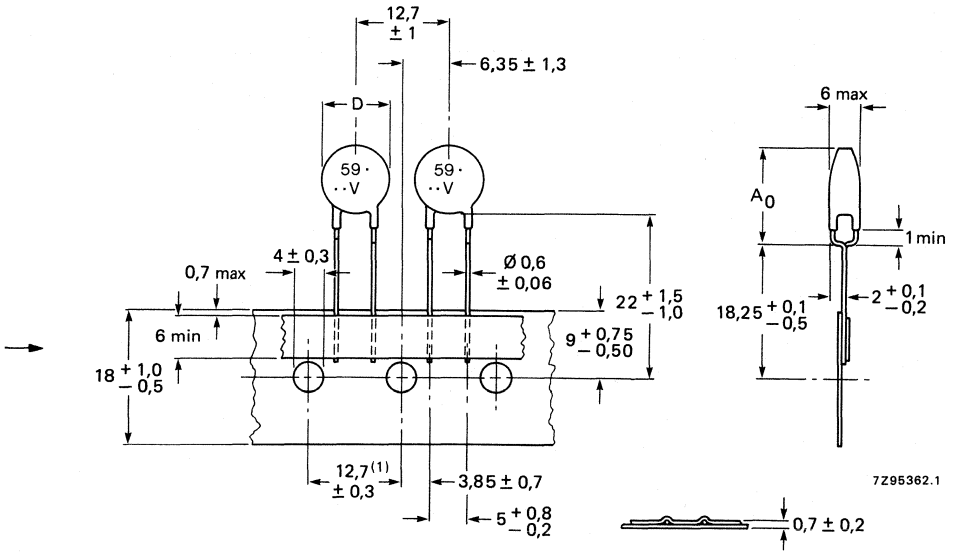

Fig. 6 Types 2322 593 3...2 on tape, $D = 9 \text{ max}$, $A_0 = 13$.

(1) Cumulative pitch error: 1mm/20 pitch.

VARISTORS

zinc oxide disc

QUICK REFERENCE DATA

Maximum a.c. voltage (r.m.s.)	60 to 460 V
Maximum d.c. voltage	85 to 615 V
Maximum non-repetitive transient current (8/20 μ s)	2500 A
Climatic category	40/125/56
Packaging	in bulk in box

APPLICATION

Suppression of transients, contact protection, spark suppression, suppression of line transients in telephony.

DESCRIPTION

A disc of low- β ceramic with two solid tinned copper wires. These varistors are white lacquered, but not insulated.

MECHANICAL DATA

Outlines

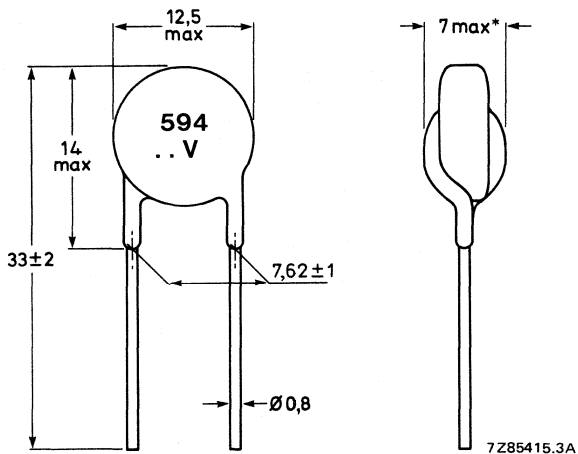

7Z85415.3A

* The device thickness is dependent upon the r.m.s. working voltage rating.

Marking

The resistors are marked with their serial number (594) and the maximum r.m.s. working voltage (see Fig. 1 and Table 1).

Mass

Approx. 1,5 g

Mounting

In any position by soldering. Leads should be as short as possible. The varistors should be mounted near the equipment or component to be protected.

Robustness of terminations

Tensile strength 10 N
Bending 5 N

Soldering

Solderability max. 240 °C, max. 4 s.
Resistance to heat 260 ± 5 °C; 10 ± 1 s

Impact

Free fall 1000 mm

Resistance to solvents

According to IEC 68-2-45, resist to R113 at 23 °C

Inflammability

Self-extinguishing according to IEC 50D, severity 10 s

ELECTRICAL DATA

Unless otherwise specified all electrical values apply at an ambient temperature of +23 ± 1 °C

Thermal resistance, body to air	approx.	60 K/W
Temperature coefficient at 1 mA, measured between +25 and +85 °C	max.	-0,065 %/K
Maximum average dissipation (including transients)		400 mW
Maximum non-repetitive transient current (8/20 μs) (note 5)		2500 A
Climatic category		40/125/56

See further Table 1

Table 1 Catalogue numbers 2322 594 6....

suffix of catalogue number	MAXIMUM RATINGS				CHARACTERISTICS			
	r.m.s. working voltage (notes 3,4)	d.c. working voltage (note 3)	transient energy (notes 5, 6)		varistor voltage $\pm 10\%$ (note 1)		maximum clamping voltage at 100 A (note 2)	typical capacitance at 1 kHz
			8/20 μ s	10/1000 μ s	min.	max.		
	V	V	J	J	V	V	V	pF
6002	60	85	18	8	90	110	185	1200
7502	75	100	21	10	108	132	225	1000
9502	95	125	25	12	135	165	285	900
1312	130	170	30	16	185	225	385	730
1512	150	200	35	18	216	264	455	600
1712	175	225	40	22	243	297	520	480
2312	230	300	50	29	324	396	686	360
2512	250	320	58	32	351	429	740	320
2712	275	350	61	35	387	473	815	290
3012	300	385	65	38	423	517	880	240
4212	420	560	85	54	612	748	1310	190
4612	460	615	96	59	675	825	1440	170

Notes

1. Voltage at a current of 1 mA, after an impulse time of 50 ms with a rise time of 10 μ s to 1 ms.
2. Measured with a standard impulse current 8/20 μ s, defined in IEC 60-2 section 6, par. 16-1.
3. Derating, see Fig. 4.
4. Sinusoidal voltage assumed. For a non-sinusoidal voltage, the crest voltage $\times 0,707$ should be used for type selection.
5. A current impulse of 8/20 μ s (defined in IEC 60-2 section 6) is used as a standard for impulse current and clamping voltage ratings. The transient energy is given for one impulse applied during the life of the component. Figure 3 gives the derating for different numbers and longer duration of impulses. The shift of the varistor voltage does not exceed $\pm 5\%$.
6. High energy surges are generally of longer duration. The max. energy for 1 impulse 10/1000 μ s is given as a reference for long duration impulses. This impulse can be characterized by peak current I_p and impulse width t_2 (virtual time to half I_p value, defined in IEC 60-2 section 6), see Fig. 5. If V_p is the clamping voltage corresponding to I_p , the energy absorbed in the VDR is determined by equation $E = K \cdot V_p \cdot I_p \cdot t_2$; K depends on t_2 . When t_1 is 8 to 10 μ s and $t_2 = 20 \mu$ s, $K = 1$; when $t_2 = 50 \mu$ s, $K = 1,2$; when $t_2 = 100 \mu$ s, $K = 1,3$; when $t_2 = 1000 \mu$ s, $K = 1,4$.

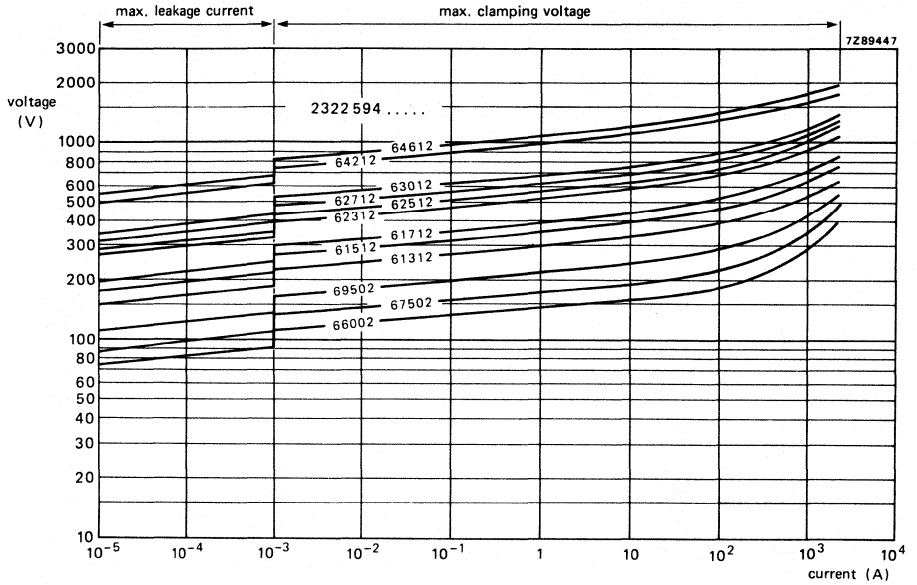

Fig. 2 V/I characteristics.

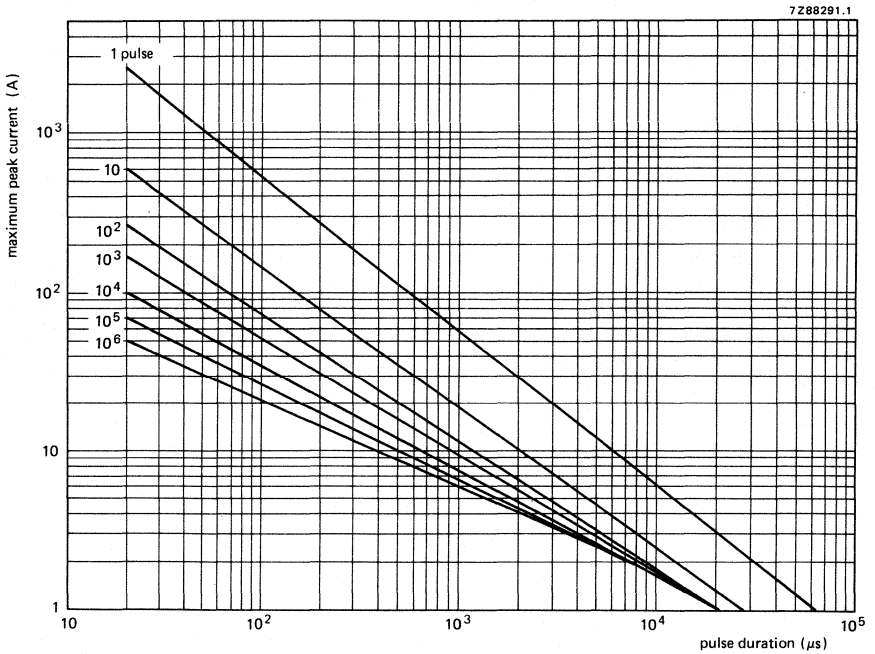

Fig. 3 Max. applicable transient current as a function of pulse duration.

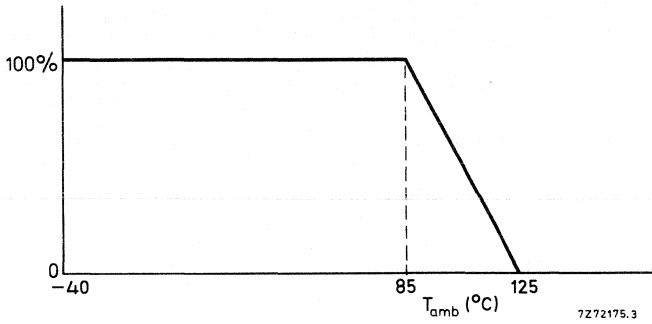

Fig. 4 Derating of max. d.c. and r.m.s. working voltage with temperature.

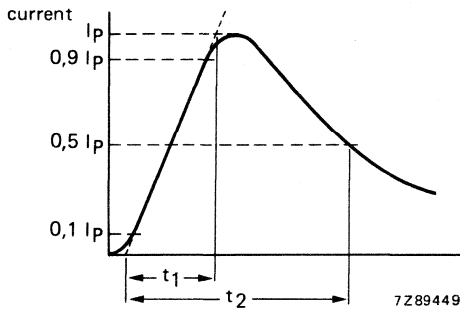

Fig. 5.

PACKAGING

The resistors 2322 594 6...2 are supplied in bulk packing only in boxes of 250.

VARISTORS

zinc oxide disc

QUICK REFERENCE DATA

Maximum a.c. voltage (r.m.s.)	60 to 460 V
Maximum d.c. voltage	85 to 615 V
Maximum non-repetitive transient current (8/20 μ s)	4500 A
Climatic category	40/125/56
Packaging	in bulk in box

APPLICATION

Suppression of transients, contact protection, spark suppression, suppression of line transients in telephony.

DESCRIPTION

A disc of low- β ceramic with two solid tinned copper wires. These varistors are white lacquered, but not insulated.

MECHANICAL DATA

Outlines

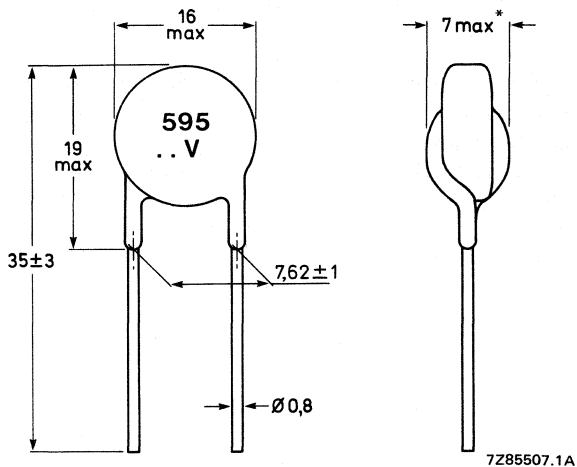

Fig. 1.

* The device thickness is dependent upon the r.m.s. working voltage rating.

Marking

The resistors are marked with their serial number (595) and the maximum r.m.s. working voltage (see Fig. 1 and Table 1).

Mass

Approx. 2 g

Mounting

In any position by soldering. Leads should be as short as possible. The varistors should be mounted near the equipment or component to be protected.

Robustness of terminations

Tensile strength 10 N

Bending 5 N

Soldering

Solderability max. 240 °C, max. 4 s

Resistance to heat 260 ± 5 °C; 10 ± 1 s

Impact

Free fall 1000 mm

Resistance to solvents

According to IEC 68-2-45, resist to R113, at 23 °C

Inflammability

Self-extinguishing according to IEC draft 50D, severity 10 s

ELECTRICAL DATA

Unless otherwise specified all electrical values apply at an ambient temperature of +23 ± 1 °C

Thermal resistance, body to air	approx.	50 K/W
Temperature coefficient at 1 mA, measured between +25 and +85 °C	max.	-0,065 %/K
Maximum average dissipation (including transients)		600 mW
Maximum non-repetitive transient current (8/20 μs) (note 5)		4500 A
Climatic category		40/125/56

See further Table 1

Table 1 Catalogue numbers 2322 595 6....

suffix of catalogue number	MAXIMUM RATINGS				CHARACTERISTICS			
	r.m.s. working voltage (notes 3, 4)	d.c. working voltage (note 3)	transient energy (notes 5, 6)		varistor voltage $\pm 10\%$ (note 1)		maximum clamping voltage at 100 A (note 2)	typical capacitance at 1 kHz
			8/20 μs	10/1000 μs	min.	max.		
	V	V	J	J	V	V	V	pF
6002	60	85	27	12	90	110	175	2300
7502	75	100	34	14	108	132	210	1900
9502	95	125	42	19	135	165	270	1700
1312	130	170	53	26	185	225	360	1300
1512	150	200	61	30	216	264	415	1100
1712	175	225	70	35	243	297	480	920
2312	230	300	89	48	324	396	650	700
2512	250	320	98	51	351	429	695	630
2712	275	350	109	56	387	473	765	600
3012	300	385	116	61	423	517	835	520
4212	420	560	150	93	612	748	1225	400
4612	460	615	167	102	675	825	1342	380

Notes

1. Voltage at a current of 1 mA, after an impulse time of 50 ms with a rise time of 10 μs to 1 ms.
2. Measured with a standard impulse current 8/20 μs , defined in IEC 60-2 section 6, par. 16-1.
3. Derating, see Fig. 4.
4. Sinusoidal voltage assumed. For a non-sinusoidal voltage, the crest voltage $\times 0,707$ should be used for type selection.
5. A current impulse of 8/20 μs (defined in IEC 60-2 section 6) is used as a standard for impulse current and clamping voltage ratings. The transient energy is given for one impulse applied during the life of the component. Figure 3 gives the derating for different numbers and longer duration of impulses. The shift of the varistor voltage does not exceed $\pm 5\%$.
6. High energy surges are generally of longer duration. The max. energy for 1 minute 10/1000 μs is given as a reference for long duration impulses. This impulse can be characterized by peak current I_p and impulse width t_2 (virtual time to half I_p value, defined in IEC 60-2 section 6), see Fig. 5. If V_p is the clamping voltage corresponding to I_p , the energy absorbed in the VDR is determined by equation $E = K \cdot V_p \cdot I_p \cdot t_2$; K depends on t_2 . When t_1 is 8 to 10 μs and $t_2 = 20 \mu\text{s}$, $K = 1$; when $t_2 = 50 \mu\text{s}$, $K = 1,2$; when $t_2 = 100 \mu\text{s}$, $K = 1,3$; when $t_2 = 1000 \mu\text{s}$, $K = 1,4$.

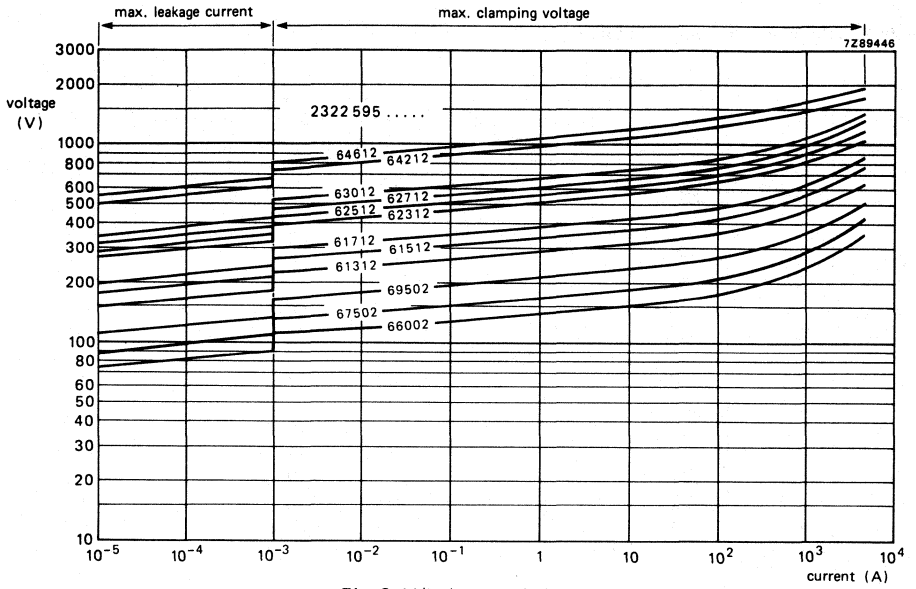

Fig. 2 V/I characteristics.

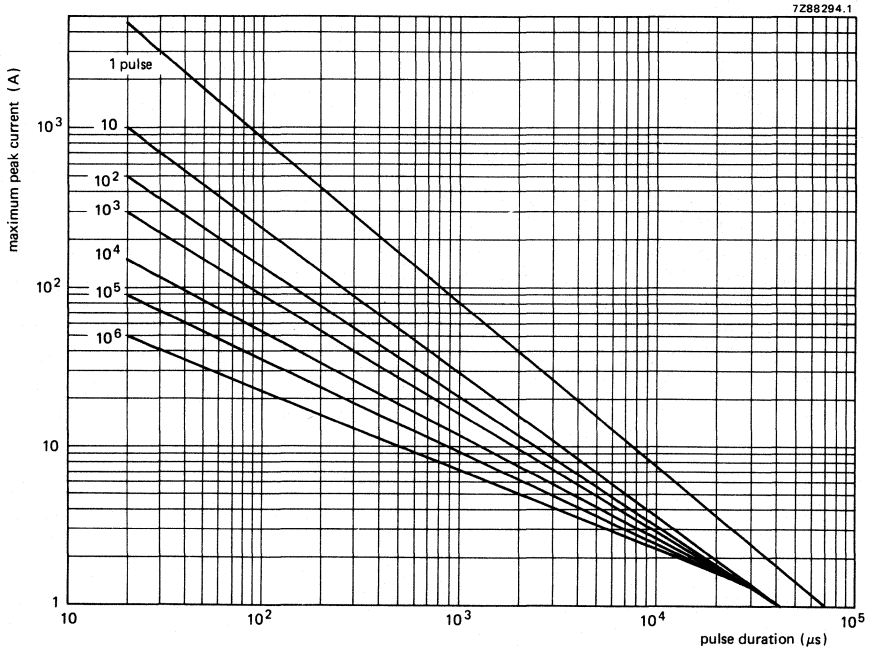

Fig. 3 Max. applicable transient current as a function of pulse duration.

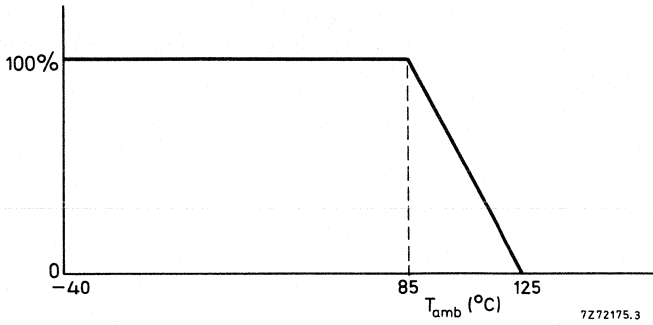

Fig. 4 Derating of max. d.c. and r.m.s. working voltage with temperature.

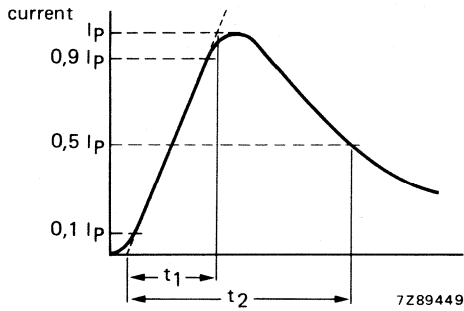

Fig. 5.

PACKAGING

The resistors 2322 595 6...2 are supplied in bulk packing only in boxes of 250.

SENSORS

GENERAL

Light dependent resistors (LDRs) are made from cadmium sulphide containing no or very few free electrons when not illuminated. Its resistance is then quite high. When it absorbs light, electrons are liberated and the conductivity of the material increases. Cadmium sulphide is therefore a photo-conductor. The approximate relationship between the resistance and illumination is:

$$R = A \cdot L^{-\alpha}$$

where: R = resistance in Ω
L = illumination in lux
A and α are constants.

The value of α depends on the cadmium sulphide used and on the manufacturing process. Values around 0,7 to 0,9 are quite common. The relationship between the resistance and the illumination is shown in the graph on the next page.

SPECTRAL RESPONSE

The resistors are only light dependent over a limited range of wavelengths. LDRs have their maximum response at about 680 nm.

TEMPERATURE DEPENDENCY

Electrons can be excited not only by photons but also by thermal agitation. The dark resistance is therefore not infinite at normal temperatures. It increases with the ambient temperature and can be decreased by cooling the device.

The temperature can also affect the resistance under illumination. At practical illumination levels and normal ambient temperatures the temperature coefficient is, however, very small and can be neglected.

RECOVERY RATE

When an LDR is brought from a certain illumination level into total darkness, the resistance does not increase immediately to the dark value. The recovery rate is specified in $k\Omega/s$ and for current LDR types it is more than 200 $k\Omega/s$ (during the first 20 seconds starting at a light level of 1,000 lux).

The recovery rate is much greater in the reverse direction, e.g. going from darkness to an illumination level of 300 lux, it takes less than 10 ms to reach a resistance which corresponds with a light level of 400 lux.

SURVEY

minimum dark resistance	light resistance	maximum dissipation at 40 °C	ambient temperature range	catalogue number
10 MΩ	75 to 300 Ω	0,1 W	-30 to +60 °C	2322 600 93001
1 MΩ	max. 110 Ω			2322 600 93002
10 MΩ	75 to 300 Ω			2322 600 94001
10 MΩ	75 to 300 Ω	0,2 W	-20 to +60 °C	2322 600 95001
10 MΩ	max. 250 Ω			2322 600 95003
1 MΩ	max. 110 Ω			2322 600 95006
10 MΩ	30 to 96 Ω			2322 600 95008
10 MΩ	150 to 300 Ω			2322 600 95009
Recovery rate			min. 200 kΩ/s	

DESCRIPTION

Disc shaped resistors made of cadmium sulphide. They are sealed and have two solid tinned copper wires.

APPLICATION

LDRs are intended for non-critical on/off applications, in which a lamp or a relay is operated either directly (low power) or via a suitable amplifier (high power) e.g. in toys.

TYPICAL CHARACTERISTICS

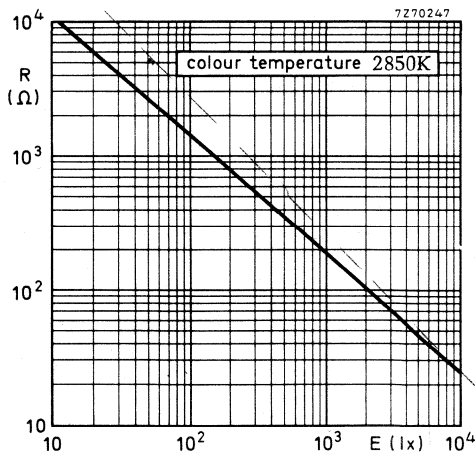

Resistance as a function of illumination.

lineair

2322 600 93001
2322 600 93002

LIGHT DEPENDENT RESISTORS

QUICK REFERENCE DATA

Dark resistance R_D	2322 600 93001 2322 600 93002	$> 10 \text{ M}\Omega$ $> 1 \text{ M}\Omega$
Light resistance R_L	2322 600 93001 2322 600 93002	75 to 300 Ω $< 110 \text{ }\Omega$
Recovery rate		$> 200 \text{ k}\Omega/\text{s}$
Maximum dissipation at 40 °C		0,1 W
Ambient temperature range		-30 to +60 °C

MECHANICAL DATA

Outline drawing

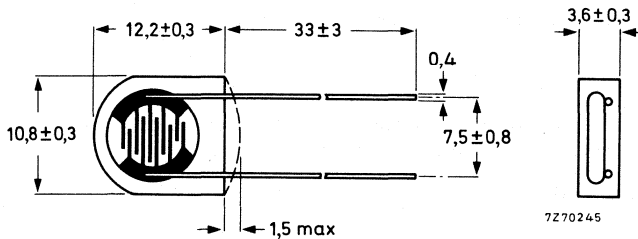

Marking

None

Mass

0,75 g approximately

Mounting

In any position by soldering the leads at least 10 mm from the body.

Robustness of terminations

Tensile strength

5 N

Bending

2,5 N

Soldering

Solderability

max. 240 °C, max. 4 s

Resistance to heat

max. 265 °C, max. 11 s

ELECTRICAL DATA

Dark resistance R_D	2322 600 93001 2322 600 93002	min. 10 M Ω min. 1 M Ω
Light resistance R_L	2322 600 93001 2322 600 93002	75 to 300 Ω max. 110 Ω
Recovery rate		min. 200 k Ω /s
Dissipation at 40 °C		max. 0,1 W
Capacitance at 1000 Hz		max. 8 pF
Repetitive peak voltage not exceeding max. dissipation		max. 150 V
Dielectric withstanding peak voltage between terminals and body		min. 200 V
Dielectric d.c. test voltage between terminals for 1 s in total darkness		200 V
Operating ambient temperature range		-30 to +60 °C

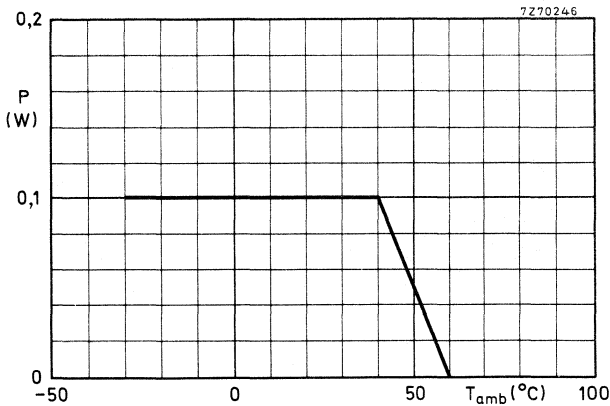

Permissible dissipation as a function of ambient temperature.

PACKAGING

250 per box

LIGHT DEPENDENT RESISTOR

QUICK REFERENCE DATA

Dark resistance R_D	$> 10 \text{ M}\Omega$
Light resistance R_L	75 to 300 Ω
Recovery rate	$> 200 \text{ k}\Omega/\text{s}$
Maximum dissipation at 40 °C	0,1 W
Ambient temperature range	-30 to + 60 °C

MECHANICAL DATA

Outline drawing

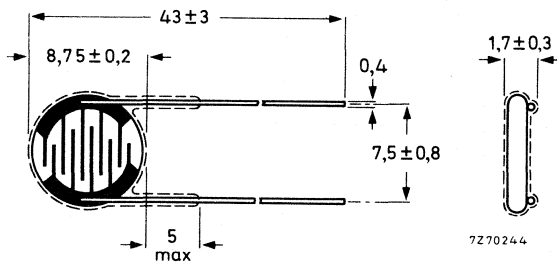

Marking

None

Mass

0,35 g approximately

Mounting

In any position by soldering the leads at least 10 mm from the body.

Robustness of terminations

Tensile strength

5 N

Bending

2,5 N

Soldering

Solderability

max. 240 °C, max. 4 s

Resistance to heat

max. 265 °C, max. 11 s

ELECTRICAL DATA

Dark resistance R_D	min. 10 M Ω
Light resistance R_L	75 to 300 Ω
Recovery rate	min. 200 k Ω /s
Dissipation at 40 °C	max. 0,1 W
Capacitance at 1000 Hz	max. 8 pF
Repetitive peak voltage, not exceeding max. dissipation	max. 150 V
Dielectric withstanding peak voltage between terminals and body	200 V
Dielectric d.c. test voltage between terminals for 1 s in total darkness	200 V
Operating ambient temperature range	-30 to +60 °C

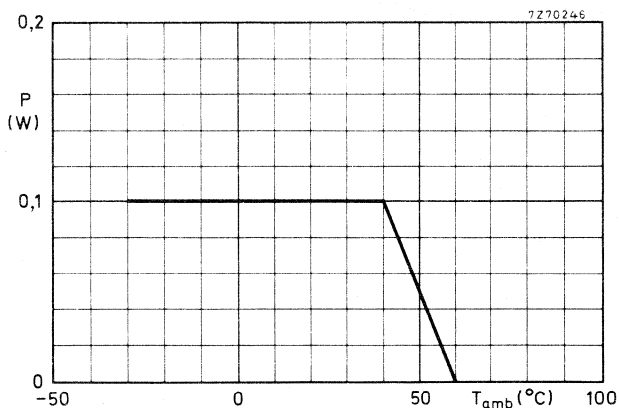

Permissible dissipation as a function of ambient temperature.

PACKAGING

250 per box

LIGHT DEPENDENT RESISTORS

QUICK REFERENCE DATA

Dark resistance R_D	$> 10 \text{ M}\Omega$ 2322 600 95006 $> 1 \text{ M}\Omega$
Light resistance R_L	30 to 300 Ω
Recovery rate	$> 200 \text{ k}\Omega/\text{s}$
Maximum dissipation at 40 °C	0,2 W
Ambient temperature range	-20 to + 60 °C

MECHANICAL DATA

Outline drawing

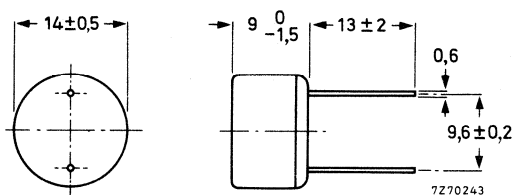

Marking

Year and month of production is printed on the body in yellow.

Mass

1,3 g approximately.

Mounting

In any position by soldering the leads at least 10 mm from the body.

Robustness of terminations

Tensile strength	10 N
Bending	5 N

Soldering

Solderability	max. 240 °C, max. 4 s
Resistance to heat	max. 265 °C, max. 11 s

ELECTRICAL DATA

catalogue number	resistance	
	dark value R_D	light value R_L
2322 600 95001	min. 10 M Ω	75 to 300 Ω
95003	min. 10 M Ω	max. 250 Ω
95006	min. 1 M Ω	max. 110 Ω
95008	min. 10 M Ω	30 to 96 Ω
95009	min. 10 M Ω	150 to 300 Ω

Recovery rate	min. 200 k Ω /s
Dissipation at 40 °C	max. 0,2 W
Capacitance at 1000 Hz	max. 6 pF
Repetitive peak voltage not exceeding max. dissipation	max. 110 V
Dielectric withstanding peak voltage between terminals and case	150 V
Dielectric d.c. test voltage between terminals for 1 s in total darkness	150 V
Operating ambient temperature range	-20 to +60 °C

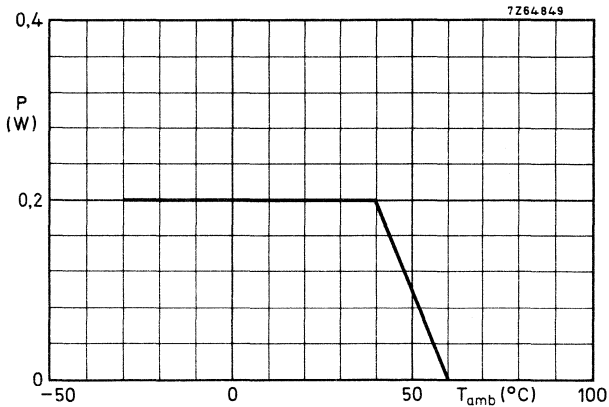

Permissible dissipation as a function of ambient temperature.

PACKAGING

125 per box

HUMIDITY SENSOR

QUICK REFERENCE DATA

Humidity range	10 to 90% R.H.
Capacitance at +25 °C, 43% R.H. and 100 kHz	122 pF ± 15%
Sensitivity between 33 and 43% R.H.	0,4 ± 0,05 pF/% R.H.
Frequency range	1 kHz to 1 MHz
Maximum a.c. or d.c. voltage	15 V
Storage humidity range	0 to 100% R.H.
Ambient temperature range	
Operating	0 to +85 °C
Storage	-25 to +85 °C

APPLICATION

For humidity measurements in e.g. electronic hygrometers for domestic use, laundry dryers with automatic switch-off, self-regulating air humidifiers.

DESCRIPTION

This capacitive atmospheric humidity sensor consists of a non-conductive foil, which is covered on both sides with a layer of gold. The dielectric constant of the foil changes as a function of the relative humidity of the ambient atmosphere and, accordingly, the capacitance value of the sensor is a measure for relative humidity. The foil is clamped between contact springs and assembled in a plastic housing. It is provided with two connecting pins fitting printed-wiring boards with a grid pitch of 2,54 mm, provision is also made for fastening with 3 mm bolts. The characteristics are not affected by an incidental condensation of water on the sensor foil. It should not be exposed to acetone vapour.

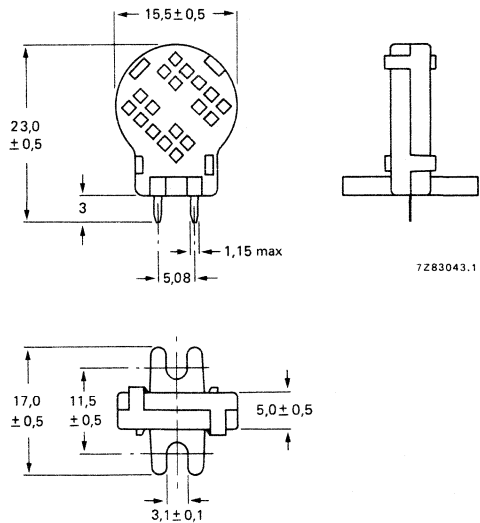

Fig. 1 Dimensions in mm.

MECHANICAL DATA**Outlines**

See Fig. 1.

Marking

PHILIPS H1

Mass

1,3 g approximately

Mounting

The item can be soldered directly onto a printed-wiring board or can be fastened with 3 mm bolts.

Soldering

Solderability

max. 240 °C, max. 4 s

Resistance to heat

max. 240 °C, max. 4 s

Robustness of terminations

Tensile strength

10 N

Impact

Free fall

1 m

Inflammability

uninflammable

ELECTRICAL DATA

Humidity range

10 to 90% R.H.

Capacitance at +25 °C, 43% R.H., 100 kHz

122 pF ± 15%

Tan δ at +25 °C and 100 kHz

< 3,5%

Sensitivity between 33 and 43% R.H.

0,4 ± 0,05 pF/% R.H.

Frequency range

1 kHz to 1 MHz

Temperature dependence

0,1% R.H./K

Response time (to 90% of indicated R.H.

change at +25 °C, in circulating air)

between 10 and 43% R.H.

< 3 min.

between 43 and 90% R.H.

< 5 min.

Hysteresis (for R.H. excursion of 10 to 90 to 10%)

3% approximately

Maximum a.c. or d.c. voltage

15 V

Storage humidity range

0 to 100% R.H.

Ambient temperature range

Operating

0 to +85 °C

Storage

-25 to +85 °C

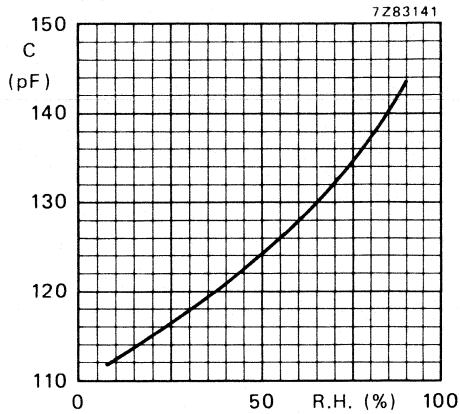

Fig. 2 Typical capacitance/relative humidity characteristic.

QUALITY LEVEL

Sampling and data evaluation for quality level according to MIL-STD-105D.

- A.Q.L. 0,25% – Inoperatives
- A.Q.L. 1% – Electrical
- A.Q.L. 1,5% – Mechanical

PACKAGING

500 pieces per box.

INDEX OF CATALOGUE NUMBERS

catalogue number	type	page	catalogue number	type	page
2322 552 0	VDR	323	2322 660 91001	PTC	149
564 02		327	91006/9		152
90		327	91017		301
592 0 . . . 6		331	93001		159
3 . . . 2		345	93006		301
5 . . . 6		331	93011/14		301
6 . . . 2		345	661 91002/5		163
593 0 . . . 6		331	91019		301
3 . . . 2		351	91021		301
5 . . . 6		331	93001/2		301
6 . . . 2		351	662 91001		168
594 5 . . . 2		357	91004/7		301
5 . . . 6		331	91016		171
595 5 . . . 2		363	93006		174
5 . . . 6		331	93015/18		301
2322 600 93001/2	LDR	372	93036		177
94001		374	93066		181
9500 .		376	98009		185
2322 610 1	NTC	27	98011		193
611 90027		32	98013		201
626 1		33	98018		205
2		39	663 91002/3		301
628 90016		44	91006		211
633 0		47	93006/7		301
1		47	664 91002/3		301
2		51	91086		215
7 . 224		57	93014/15		301
636 90018		61	670 90003		219
640 1		65	672 91002/11		221
19		69	91016		301
90004		71	91026/35		221
90005		77	92045/53		229
90007		83	93003		301
90012		88	98001		237
90013		90	680 00001		243
90014		94	03001		245
90015		97	04001		247
90021		83	04002		249
98004		71	04003		251
98005		77	04004		253
98013		90	04022		255
98015		97	93021/37		257
642 6		101	2322 691 90001	H.S.	379
7		108			
644 90004/5		111			
90012		117			
645		119			

Argentina: PHILIPS ARGENTINA S.A., Div. Elcoma, Vedia 3892, 1430 BUENOS AIRES, Tel. 541-7141/7242/7343/7444/7545.

Australia: PHILIPS INDUSTRIES HOLDINGS LTD., Elcoma Division, 11 Waltham Street, ARTARMON, N.S.W. 2064, Tel. (02)439 3322.

Austria: ÖSTERREICHISCHE PHILIPS BAUELEMENTE INDUSTRIE G.m.b.H., Triester Str. 64, A-1101 WIEN, Tel. 6291 11.

Belgium: N.V. PHILIPS & MBLE ASSOCIATED, 9 rue du Pavillon, B-1030 BRUXELLES, Tel. (02) 242 74 00.

Brazil: IBRAPE, Caixa Postal 7383, Av. Brigadeiro Faria Lima, 1735 SAO PAULO, SP, Tel. (011) 211-2600.

Canada: PHILIPS ELECTRONICS LTD., Elcoma Division, 601 Milner Ave., SCARBOROUGH, Ontario, M1B 1M8, Tel. 292-5161.

Chile: PHILIPS CHILENA S.A., Av. Santa Maria 0760, SANTIAGO, Tel. 39-4001.

Colombia: IND. PHILIPS DE COLOMBIA S.A., c/o IPRELENCO LTD., Cra. 21, No. 56-17, BOGOTA, D.E., Tel. 2497624.

Denmark: MINIWATT A/S, Strandlodsvej 2, P.O. Box 1919, DK 2300 COPENHAGEN S, Tel. (01) 5411 33.

Finland: OY PHILIPS AB, Elcoma Division, Kaivokatu 8, SF-00100 HELSINKI 10, Tel. 1727 71.

France: R.T.C. LA RADIOTECHNIQUE-COMPELEC, 130 Avenue Ledru Rollin, F-75540 PARIS 11, Tel. 338 80-00.

Germany (Fed. Republic): VALVO, UB Bauelemente der Philips G.m.b.H., Valvo Haus, Burchardstrasse 19, D-2 HAMBURG 1, Tel. (040) 3296-0.

Greece: PHILIPS S.A. HELLENIQUE, Elcoma Division, 52, Av. Syngrou, ATHENS, Tel. 9215111.

Hong Kong: PHILIPS HONG KONG LTD., Elcoma Div., 15/F Philips Ind. Bldg., 24-28 Kung Yip St., KWAI CHUNG, Tel. (0)-245121.

India: PEICO ELECTRONICS & ELECTRICALS LTD., Elcoma Dept., Band Box Building, 254-D Dr. Annie Besant Rd., BOMBAY - 400025, Tel. 4220387/4220311.

Indonesia: P.T. PHILIPS-RALIN ELECTRONICS, Elcoma Div., Panim Bank Building, 2nd Fl., Jl. Jend. Sudirman, P.O. Box 223, JAKARTA, Tel. 716131.

Ireland: PHILIPS ELECTRICAL (IRELAND) LTD., Newstead, Clonskeagh, DUBLIN 14, Tel. 693355.

Italy: PHILIPS S.p.A., Sezione Elcoma, Piazza IV Novembre 3, I-20124 MILANO, Tel. 2-6752.1.

Japan: NIHON PHILIPS CORP., Shuwa Shinagawa Bldg., 26-33 Takanawa 3-chome, Minato-ku, TOKYO (108), Tel. 448-5611. (IC Products) SIGNETICS JAPAN LTD., 8-7 Sanbancho Chiyoda-ku, TOKYO 102, Tel. (03) 230-1521.

Korea (Republic of): PHILIPS ELECTRONICS (KOREA) LTD., Elcoma Div., Philips House, 260-199 Itaewon-dong, Yongsan-ku, SEOUL, Tel. 794-4202.

Malaysia: PHILIPS MALAYSIA SDN. BERHAD, No. 4 Persiaran Barat, Petaling Jaya, P.O.B. 2163, KUALA LUMPUR, Selangor, Tel. 7744 11.

Mexico: ELECTRONICA, S.A. de C.V., Carr. México-Toluca km. 62.5, TOLUCA, Edo. de México 50140, Tel. Toluca 91 (721) 613-00.

Netherlands: PHILIPS NEDERLAND, Marktgroep Elonco, Postbus 90050, 5600 PB EINDHOVEN, Tel. (040) 793333.

New Zealand: PHILIPS NEW ZEALAND LTD., Elcoma Division, 110 Mt. Eden Road, C.P.O. Box 1041, AUCKLAND, Tel. 605-914.

Norway: NORSK A/S PHILIPS, Electronica Dept., Sandstuveien 70, OSLO 6, Tel. 680200.

Peru: CADESA, Av. Alfonso Ugarte 1268, LIMA 5, Tel. 326070.

Philippines: PHILIPS INDUSTRIAL DEV. INC., 2246 Pasong Tamo, P.O. Box 911, Makati Comm. Centre, MAKATI-RIZAL 3116, Tel. 86-89-51 to 59.

Portugal: PHILIPS PORTUGUESA S.A.R.L., Av. Eng. Duarte Pacheco 6, 1009 LISBOA Codex, Tel. 683121.

Singapore: PHILIPS PROJECT DEV. (Singapore) PTE LTD., Elcoma Div., Lorong 1, Toa Payoh, SINGAPORE 1231, Tel. 3502000.

South Africa: EDAC (PTY.) LTD., 3rd Floor Rainer House, Upper Railway Rd. & Ôve St., New Doornfontein, JOHANNESBURG 2001, Tel. 614-2362/9.

Spain: MINIWATT S.A., Balmes 22, BARCELONA 7, Tel. 301 63 12.

Sweden: PHILIPS KOMPONENTER A.B., Lidingövägen 50, S-11584 STOCKHOLM 27, Tel. 08/7821000.

Switzerland: PHILIPS A.G., Elcoma Dept., Allmendstrasse 140-142, CH-8027 ZÜRICH, Tel. 01-4882211.

Taiwan: PHILIPS TAIWAN LTD., 3rd Fl., San Min Building, 57-1, Chung Shan N. Rd, Section 2, P.O. Box 22978, TAIPEI, Tel. (02)-5631717.

Thailand: PHILIPS ELECTRICAL CO. OF THAILAND LTD., 283 Silom Road, P.O. Box 961, BANGKOK, Tel. 233-6330-9.

Turkey: TÜRK PHILIPS TICARET A.S., Elcoma Department, İnönü Cad. No. 78-80, ISTANBUL, Tel. 4359 10.

United Kingdom: MULLARD LTD., Mullard House, Torrington Place, LONDON WC1E 7HD, Tel. 01-5806633.

United States: (Active Devices & Materials) AMPEREX SALES CORP., Providence Pike, SLATERSVILLE, R.I. 02876, Tel. (401) 762-9000. (Passive Devices) MEPCO/ELECTRA INC., Columbia Rd., MORRISTOWN, N.J. 07960, Tel. (201) 539-2000. (Passive Devices & Electromechanical Devices) CENTRALAB INC., 5855 N. Glen Park Rd., MILWAUKEE, WI 53201, Tel. (414)228-7380. (IC Products) SIGNETICS CORPORATION, 811 East Arques Avenue, SUNNYVALE, California 94086, Tel. (408) 739-7700.

Uruguay: LUZILECTRON S.A., Avda Uruguay 1287, P.O. Box 907, MONTEVIDEO, Tel. 91 4321.

Venezuela: IND. VENEZOLANAS PHILIPS S.A., c/o MAGNETICA S.A., Calle 6, Ed. Las Tres Jotas, App. Post. 78117, CARACAS, Tel. (02) 2393931

For all other countries apply to: Philips Electronic Components and Materials Division, International Business Relations, Building BAE, P.O. Box 218, 5600 MD EINDHOVEN, The Netherlands, Tel. +31 4072 3304, Telex 35000 phntcn